

THIS DRAWING IS UNPUBLISHED. RELEASED FOR PUBLICATION 20
 © COPYRIGHT 20 BY - ALL RIGHTS RESERVED.

REVISIONS				
P	LTR	DESCRIPTION	DATE	APVD
C		REVISED PER ECR-19-003973	03APR2019	BDA DS

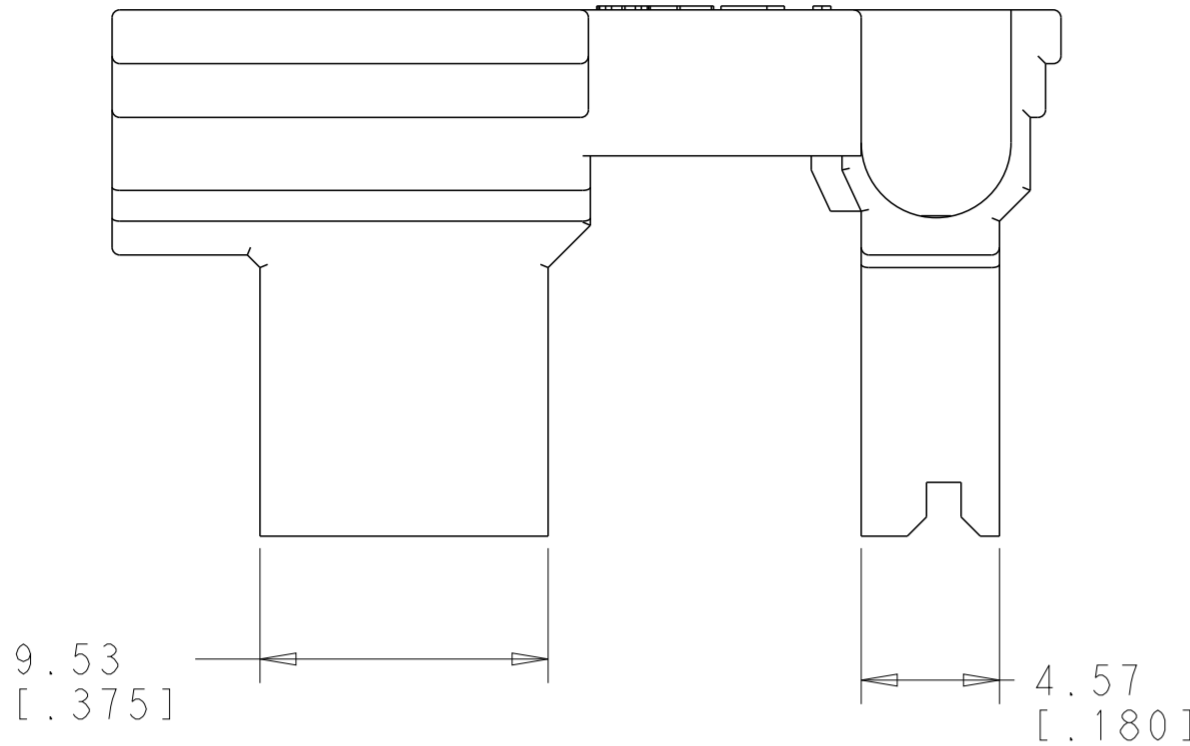

- 1 THIS PART ACCEPTS TERMINAL 63009 OR 63963 18-14 GAUGE WIRE.
- 2 FOR PROPER ENGAGEMENT THE MATING TAB MUST HAVE A MIN OF .315 USEABLE LENGTH.
- 3 PRELIMINARY PART NUMBER. NOT RELEASED FOR PRODUCTION
- 4 OBSOLETE PARTS
- 5 PARTS MAY APPEAR MEDIUM COLORED TO LIGHT COLORED AND EXHIBIT A MARBLING EFFECT.

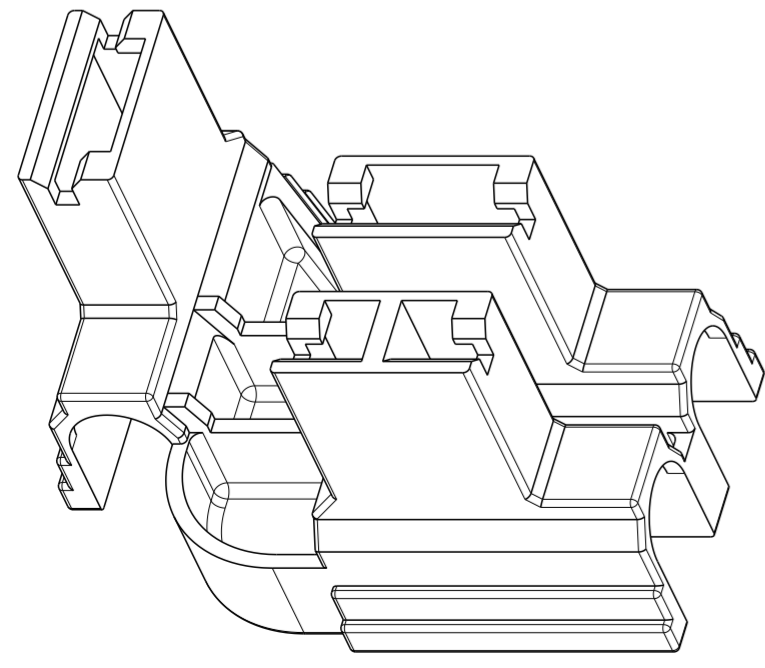
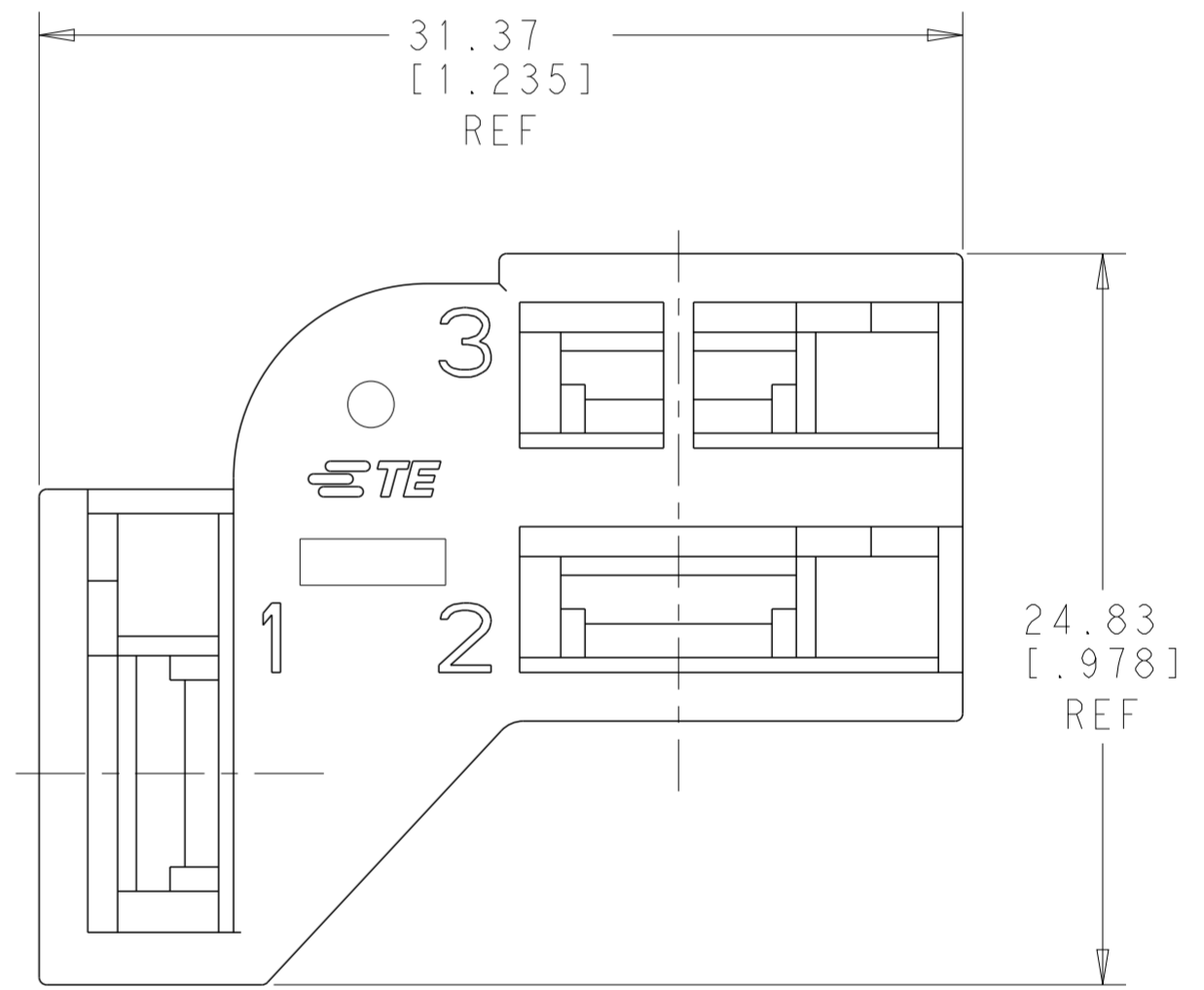
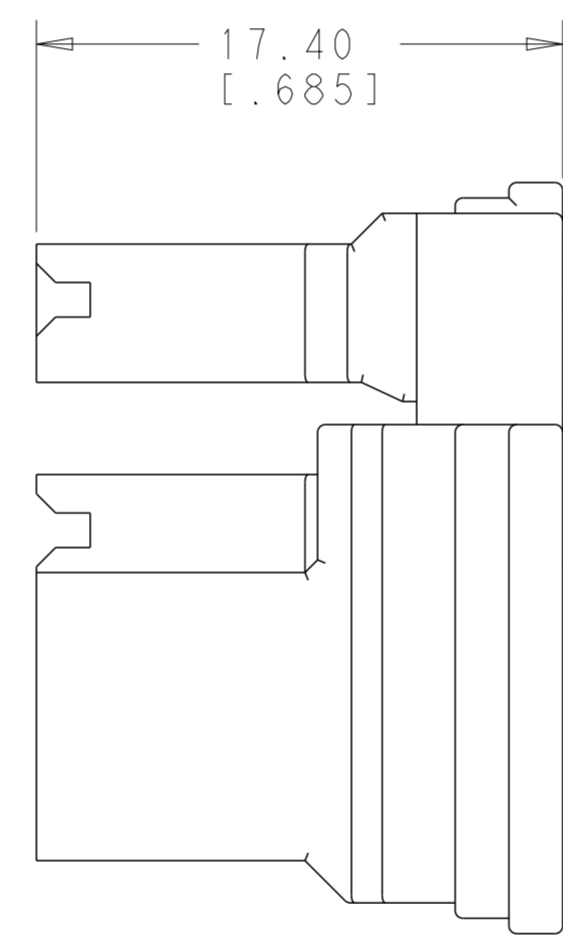
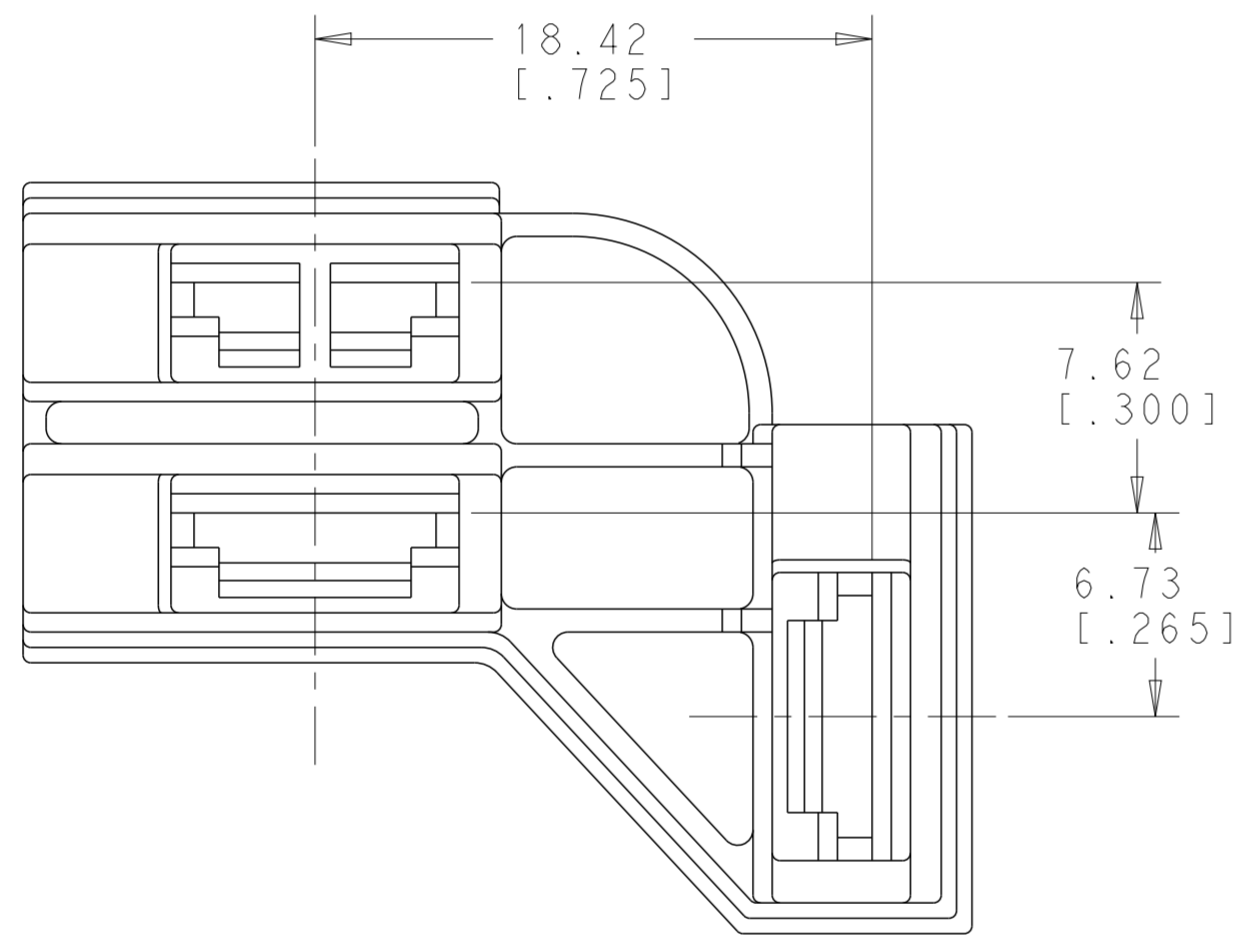

SCALE 3:1

4 SUPERSEDED BY 1-1969706-1	BLACK	66 Nylon V0, Black, GWT	5 1-1969706-1
	-	-	3 1969706-2
	-	-	1-1969706-1
	COLOR	MATERIAL	PART NO.

THIS DRAWING IS A CONTROLLED DOCUMENT.		DWN JR RUTH 17OCT14	TE Connectivity	
DIMENSIONS: mm [INCHES]		CHK DAVE HUMPHREY 17OCT14		
TOLERANCES UNLESS OTHERWISE SPECIFIED:		APVD DAVE HUMPHREY 17OCT14	NAME HOUSING, RECEPTACLE, FLAG FASTON, 6.35 [.250] SERIES, 2 POSITION	
0 PLC ±	1 PLC ±	PRODUCT SPEC	SIZE CAGE CODE DRAWING NO RESTRICTED TO	
2 PLC ±0.25 [.010]	3 PLC ±	APPLICATION SPEC	A200779 C-1969706	
4 PLC ±	ANGLES ±	WEIGHT	SCALE 1:1 SHEET 1 OF 1 REV C	
MATERIAL NYLON, V0 NO DRIP	FINISH COLOR-BLACK	Customer Drawing		