

KAI-0330

648 (H) x 484 (V) Interline CCD Image Sensor

Description

The KAI-0330 Image Sensor is a high performance, low cost, progressive scan 648 (H) × 484 (V) (1/2" optical format) Interline CCD Image Sensor designed specifically for demanding machine vision, surveillance, and computer input imaging applications.

Available in both single- and dual-output configurations, frame rates up to 120 Hz are available, providing the ability to design an image capture device that is up to 4× faster than traditional CCD image sensors. In addition, 9 μm square pixels with microlenses and anti-blooming structure provide high sensitivity and excellent specular reflection blooming control. Coupled with the additional benefits of electronic shutter, rapid clearing of horizontal lines for faster sub-region readout, and availability in color and monochrome configurations, this sensor is an ideal choice for challenging imaging applications.

Table 1. GENERAL SPECIFICATIONS

Parameter	Typical Value
Architecture	Interline CDD; Progressive Scan
Total Number of Pixels	680 (H) × 496 (V)
Number of Effective Pixels	648 (H) × 484 (V)
Number of Active Pixels	648 (H) × 484 (V)
Pixel Size	9.0 μm(H) × 9.0 μm (V)
Active Image Size	5.832 mm (H) × 4.356 mm (V), 7.28 mm (Diagonal), 1/2" Optical Format
Aspect Ratio	4:3
Number of Outputs	1 or 2
Saturation Signal	30.000 e ⁻
Output Sensitivity	11.5 μV/e ⁻
Quantum Efficiency –ABA (490 nm) –CBA (620 nm, 530 nm, 460 nm)	36% 25%, 26%, 32%
Total Sensor Noise	0.5 mV rms
Dynamic Range	57 dB
Dark Current	< 0.5 nA/cm ²
Dark Current Doubling Temperature	8°C
Charge Transfer Efficiency	0.99999
Smear	0.01%
Image Lag	Negligible
Maximum Data Rate	30 MHz
Package	20-Pin CERDIP
Cover Glass	Clear Glass

NOTE: All Parameters are specified at T = 40°C unless otherwise noted.



ON Semiconductor®

www.onsemi.com

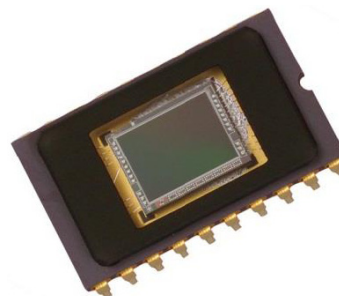

Figure 1. KAI-0330 Interline CCD Image Sensor

Features

- Front Illuminated Interline Architecture
- Progressive Scan
- Electronic Shutter
- Integral RGB Color Filter Array (Optional)
- On-Chip Dark Reference Pixels
- Low Dark Current
- Dual Output Shift Registers
- Anti-Blooming Protection
- Negligible Lag
- Low Smear

Applications

- Machine Vision

ORDERING INFORMATION

See detailed ordering and shipping information on page 2 of this data sheet.

KAI-0330

ORDERING INFORMATION

Table 2. ORDERING INFORMATION – KAI-0330 IMAGE SENSOR

Part Number	Description	Marking Code
KAI-0330-AAA-CP-BA-Dual Output	Monochrome, No Microlens, CERDIP Package (Sidebrazed), Taped Clear Cover Glass (No Coatings), Standard Grade, Dual Output	KAI-0330D Serial Number
KAI-0330-AAA-CP-AE-Dual Output	Monochrome, Telecentric Microlens, CERDIP Package (Sidebrazed), Taped Clear Cover Glass (No Coatings), Engineering Grade, Dual Output	
KAI-0330-ABA-CB-AA-Single Output	Monochrome, Telecentric Microlens, CERDIP Package (Sidebrazed), Clear Cover Glass (No Coatings), Standard Grade, Single Output	KAI-0330SM Serial Number
KAI-0330-ABA-CB-BA-Dual Output	Monochrome, Telecentric Microlens, CERDIP Package (Sidebrazed), Clear Cover Glass (No Coatings), Standard Grade, Dual Output	KAI-0330DM Serial Number
KAI-0330-ABA-CB-AE-Dual Output	Monochrome, Telecentric Microlens, CERDIP Package (Sidebrazed), Clear Cover Glass (No Coatings), Engineering Grade, Dual Output	
KAI-0330-CBA-CB-BA-Dual Output	Color (Bayer RGB), Telecentric Microlens, CERDIP Package (Sidebrazed), Clear Cover Glass (No Coatings), Standard Grade, Dual Output	KAI-0330DCM Serial Number
KAI-0330-CBA-CB-AE-Dual Output	Color (Bayer RGB), Telecentric Microlens, CERDIP Package (Sidebrazed), Clear Cover Glass (No Coatings), Engineering Grade, Dual Output	

Table 3. ORDERING INFORMATION – EVALUATION SUPPORT

Part Number	Description
KAI-0330-12-30-A-GEVK	Evaluation Board (Complete Kit)

See the ON Semiconductor *Device Nomenclature* document (TND310/D) for a full description of the naming convention used for image sensors. For reference documentation, including information on evaluation kits, please visit our web site at www.onsemi.com.

DEVICE DESCRIPTION

Architecture

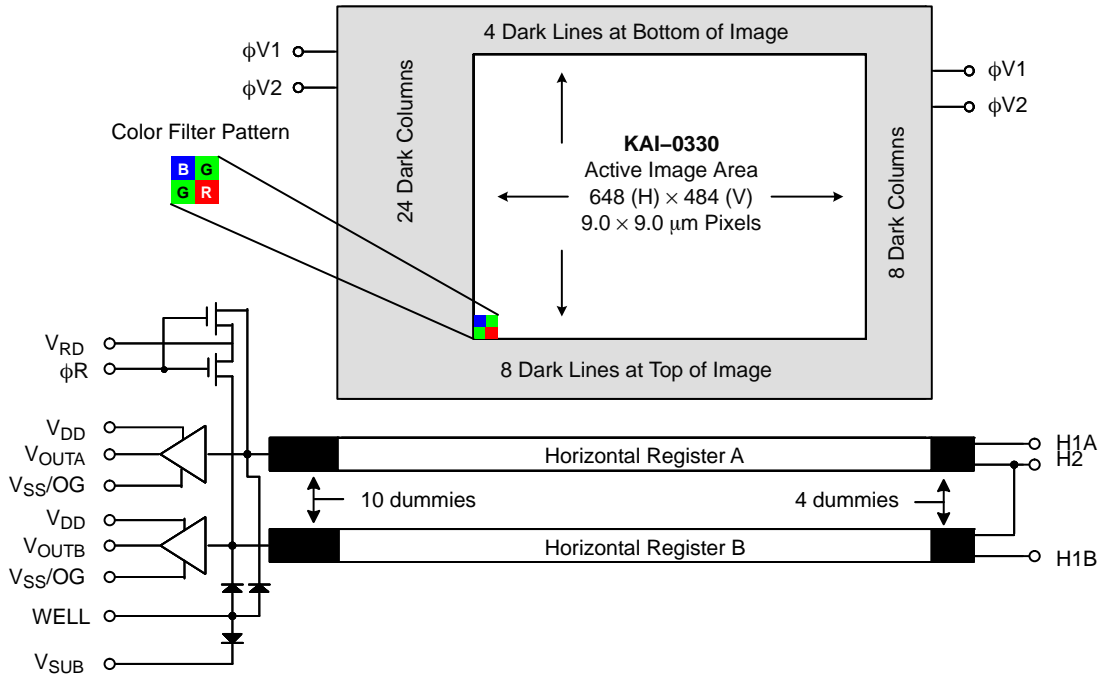

Figure 2. Functional Block Diagram

The KAI-0330 consists of 648×484 photodiodes, 680 vertical (parallel) CCD shift registers (VCCDs), and dual 496 pixel horizontal (serial) CCD shift registers (HCCDs) with independent output structures. The device can be operated in either single or dual line mode. The advanced, progressive-scan architecture of the device allows the entire image area to be read out in a single scan. The active pixels are surrounded by an additional 32 columns and 12 rows of light-shielded dark reference pixels.

Image Acquisition

An electronic representation of an image is formed when incident photons falling on the sensor plane create electron-hole pairs within the individual silicon photodiodes. These photoelectrons are collected locally by the formation of potential wells at each photosite. Below photodiode saturation, the number of photoelectrons collected at each pixel is linearly dependent on light level and exposure time and non-linearly dependent on wavelength. When the photodiode's charge capacity is reached, excess electrons are discharged into the substrate to prevent blooming.

Charge Transport

The accumulated or integrated charge from each photodiode is transported to the output by a three-step process. The charge is first transported from the photodiodes to the VCCDs by applying a large positive voltage to the phase-one vertical clock ($\phi V1$). This reads out every row, or line, of photodiodes into the VCCDs.

The charge is then transported from the VCCDs to the HCCDs line by line. Finally, the HCCDs transport these rows of charge packets to the output structures pixel by pixel. On each falling edge of the horizontal clock, $\phi H2$, these charge packets are dumped over the output gate (OG, Figure 3) onto the floating diffusion (FDA and FDB, Figure 3).

Both the horizontal and vertical shift registers use traditional two-phase complementary clocking for charge transport. Transfer to the HCCDs begins when $\phi V2$ is clocked high and then low (while holding $\phi H1A$ high) causing charge to be transferred from $\phi V1$ to $\phi V2$ and subsequently into the A HCCD. The A register can now be read out in single line mode. If it is desired to operate the device in a dual line readout mode for higher frame rates, this line is transferred into the B HCCD by clocking $\phi H1A$ to a low state, and $\phi H1B$ to a high state while holding $\phi H2$ low. After $\phi H1A$ is returned to a high state, the next line can be transferred into the A HCCD. After this clocking sequence, both HCCDs are read out in parallel.

The charge capacity of the horizontal CCDs is slightly more than twice that of the vertical CCDs. This feature allows the user to perform two-to-one line aggregation in the charge domain during V-to-H transfer. This device is also equipped with a fast dump feature that allows the user to selectively dump complete lines (or rows) of pixels at a time. This dump, or line clear, is also accomplished during the V-to-H transfer time by clocking the fast dump gate.

Output Structure

Charge packets contained in the horizontal register are dumped pixel by pixel, onto the floating diffusion output node whose potential varies linearly with the quantity of charge in each packet. The amount of potential change is determined by the expression $\Delta V_{FD} = \Delta Q / C_{FD}$. A three-stage source-follower amplifier is used to buffer this signal voltage off chip with slightly less than unity gain.

The translation from the charge domain to the voltage domain is quantified by the output sensitivity or charge to voltage conversion in terms of $\mu V/e^-$. After the signal has been sampled off-chip, the reset clock (ϕR) removes the charge from the floating diffusion and resets its potential to the reset-drain voltage (V_{RD}).

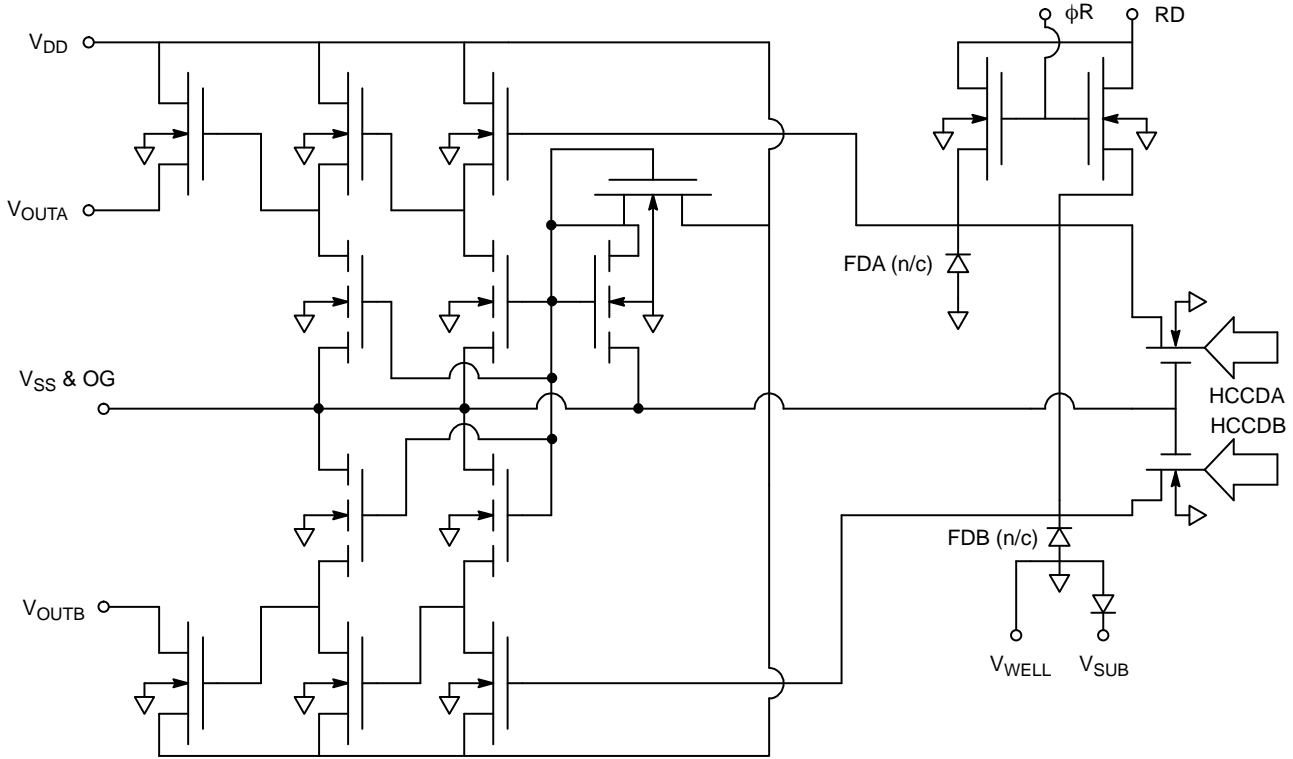

NOTE: For the single output version, V_{OUTB} is not active.

Figure 3. Output Structure

Electronic Shutter

The KAI-0330 provides a structure for the prevention of blooming which may be used to realize a variable exposure time as well as performing the anti-blooming function. The anti-blooming function limits the charge capacity of the photodiode by draining excess electrons vertically into the substrate (hence the name Vertical Overflow Drain or VOD). This function is controlled by applying a large potential to the device substrate (device terminal SUB). If a sufficiently large voltage pulse ($VES \approx 40 V$) is applied to the substrate, all photodiodes will be emptied of charge through the substrate, beginning the integration period. After returning the substrate voltage to the nominal value, charge can accumulate in the diodes and the charge packet is subsequently readout onto the VCCD at the next occurrence of the high level on $\phi V1$. The integration time is then the time between the falling edges of the substrate shutter pulse and $\phi V1$. This scheme allows electronic variation of the exposure time by a variation in the clock timing while maintaining a standard video frame rate.

Application of the large shutter pulse must be avoided during the horizontal register readout or an image artifact will appear due to feed-through. The shutter pulse VES must be “hidden” in the horizontal retrace interval. The integration time is changed by skipping the shutter pulse from one horizontal retrace interval to another.

The smear specification is not met under electronic shutter operation. Under constant light intensity and spot size, if the electronic exposure time is decreased, the smear signal will remain the same while the image signal will decrease linearly with exposure. Smear is quoted as a percentage of the image signal and so the percent smear will increase by the same factor that the integration time has decreased. This effect is basic to interline devices.

Extremely bright light can potentially harm solid state imagers such as Charge-Coupled Devices (CCDs). Refer to Application Note *Using Interline CCD Image Sensors in High Intensity Visible Lighting Conditions*.

Physical Description

Pin Description and Device Orientation

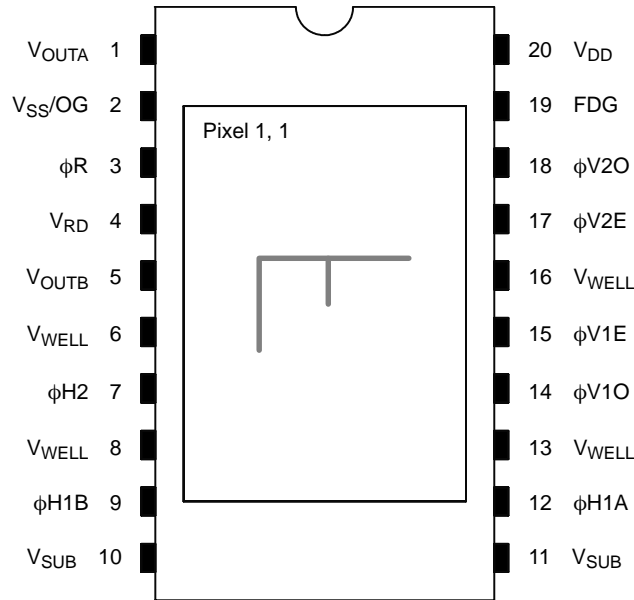

Figure 4. Pinout Diagram (Top View)

Table 4. PIN DESCRIPTION

Pin No.	Symbol	Description
1	V _{OUTA}	Video Output Channel A
2	V _{SS/OG}	Output Amplifier Return and OG
3	φ _R	Reset Clock
4	V _{RD}	Reset Drain
5	V _{OUTB}	Video Output Channel B (Note 1)
6, 8, 13, 16	V _{WELL}	P-Well (Ground)
7	φ _{H2}	A & B Horizontal CCD Clock – Phase 2
9	φ _{H1B}	B Horizontal CCD Clock – Phase 1
10, 11	V _{SUB}	Substrate
12	φ _{H1A}	A Horizontal CCD Clock – Phase 1
14	φ _{V1O}	Vertical CCD Clock – Phase 1, Odd Field (Note 2)
15	φ _{V1E}	Vertical CCD Clock – Phase 1, Even Field (Note 2)
17	φ _{V2E}	Vertical CCD Clock – Phase 2, Even Field (Note 3)
18	φ _{V2O}	Vertical CCD Clock – Phase 2, Odd Field (Note 3)
19	FDG	Fast Dump Gate
20	V _{DD}	Output Amplifier Supply

1. For the single output version, V_{OUTB} is not active.
2. Pins 14 and 15 must be connected together – only 1 Phase 1 clock driver is required.
3. Pins 17 and 18 must be connected together – only 1 Phase 2 clock driver is required.

IMAGING PERFORMANCE

All the following values were derived using nominal operating conditions using the recommended timing. Unless otherwise stated, readout time = 40 ms, integration time = 40 ms and sensor temperature = 40°C. Correlated double sampling of the output is assumed and recommended. Many

units are expressed in electrons, to convert to voltage, multiply by the amplifier sensitivity.

Defects are excluded from the following tests and the signal output is referenced to the dark pixels at the end of each line unless otherwise specified.

Table 5. ELECTRO-OPTICAL FOR KAI-0330-CBA

Parameter	Symbol	Min.	Nom.	Max.	Unit
Optical Fill Factor	F	–	55.0	–	%
Saturation Exposure (Note 1)	E _{SAT}	–	0.046	–	μJ/cm ²
Red Peak Quantum Efficiency λ = 620 nm (Note 2)	QE _R	–	25	–	%
Green Peak Quantum Efficiency λ = 530 nm (Note 2)	QE _G	–	26	–	%
Blue Peak Quantum Efficiency λ = 460 nm (Note 2)	QE _B	–	32	–	%
Green Photoresponse Shading (Note 4)	R _{GS}	–	6	–	%
Photoresponse Non-Uniformity (Note 3)	PRNU	–	5.0	–	p-p %
Photoresponse Non-Linearity	PRNL	–	5.0	–	%
Amplifier Sensitivity	ΔV/ΔN	–	11.5	–	μV/e ⁻

1. For λ = 530 nm wavelength, and V_{SAT} = 350 mV.
2. Refer to typical values from Figure 5.
3. Under uniform illumination with output signal equal to 280 mV.
4. This is the global variation in chip output for green pixels across the entire chip.
5. It is recommended to use low-pass filter with λ_{CUT-OFF} at ~ 680 nm for high performance.

Table 6. ELECTRO-OPTICAL FOR KAI-0330-ABA

Parameter	Symbol	Min.	Nom.	Max.	Unit
Optical Fill Factor	F	–	55.0	–	%
Saturation Exposure (Note 1)	E _{SAT}	–	0.037	–	μJ/cm ²
Peak Quantum Efficiency (Note 2)	QE	–	36	–	%
Photoresponse Non-Uniformity (Note 3)	PRNU	–	5.0	–	p-p %
Photoresponse Non-Linearity	PRNL	–	5.0	–	%

1. For λ = 550 nm wavelength, and V_{SAT} = 350 mV.
2. Refer to typical values from Figure 6.
3. Under uniform illumination with output signal equal to 280 mV.

Table 7. CCD IMAGE SPECIFICATIONS

Parameter	Symbol	Min.	Nom.	Max.	Unit
Output Saturation Voltage (Notes 1, 2, 8)	V _{SAT}	–	350	–	mV
Dark Current	I _D	–	–	0.5	nA
Dark Current Doubling Temperature	DCDT	7	8	10	°C
Charge Transfer Efficiency (Notes 2, 3)	CTE	–	0.99999	–	
Horizontal CCD Frequency (Note 4)	f _H	–	–	30	MHz
Image Lag (Note 5)	IL	–	–	100	e ⁻
Blooming Margin (Notes 6, 8)	X _{AB}	–	100	–	
Vertical Smear (Note 7)	Smr	–	0.01	–	%

1. V_{SAT} is the green pixel mean value at saturation as measured at the output of the device with X_{AB} = 1. V_{SAT} can be varied by adjusting V_{SUB}.
2. Measured at sensor output.
3. With stray output load capacitance of C_L = 10 pF between the output and AC ground.
4. Using maximum CCD frequency and/or minimum CCD transfer times may compromise performance.
5. This is the first field decay lag measured by strobe illuminating the device at (H_{SAT}, V_{SAT}), and by then measuring the subsequent frame's average pixel output in the dark.
6. X_{AB} represents the increase above the saturation-irradiance level (H_{SAT}) that the device can be exposed to before blooming of the vertical shift register will occur. It should also be noted that V_{OUT} rises above V_{SAT} for irradiance levels above H_{SAT}, as shown in Figure 8.
7. Measured under 10% (~100 lines) image height illumination with white light source and without electronic shutter operation and below V_{SAT}.
8. It should be noted that there is tradeoff between X_{AB} and V_{SAT}.

KAI-0330

Table 8. OUTPUT AMPLIFIER @ $V_{DD} = 15\text{ V}$, $V_{SS} = 0.0\text{ V}$

Description	Symbol	Min.	Nom.	Max.	Unit
Output DC Offset (Notes 1, 2)	V_{ODC}	–	7	–	V
Power Dissipation (Note 3)	P_D	–	55	–	mW
Output Amplifier Bandwidth (Notes 1, 4)	f_{-3db}	–	140	–	MHz
Off-Chip Load	C_L	–	–	10	pF

1. Measured at sensor output with constant current load of $I_{OUT} = 5\text{ mA}$ per output.
2. Measured with $V_{RD} = 9\text{ V}$ during the floating-diffusion reset interval, (ϕ_R high), at the sensor output terminals.
3. Both channels.
4. With stray output load capacitance of $C_L = 10\text{ pF}$ between the output and AC ground.

Table 9. GENERAL

Description	Symbol	Min.	Nom.	Max.	Unit
Total Sensor Noise (Note 1)	$V_{n-TOTAL}$	–	0.5	–	mV, rms
Dynamic Range (Note 2)	DR	–	–	58	dB

1. Includes amplifier noise and dark current shot noise at data rates of 10 MHz. The number is based on the full bandwidth of the amplifier. It can be reduced when a low pass filter is used.
2. Uses $20\text{ Log}(V_{SAT} / V_{n-TOTAL})$ where V_{SAT} refers to the output saturation signal.

TYPICAL PERFORMANCE CURVES

Color with Microlens Quantum Efficiency

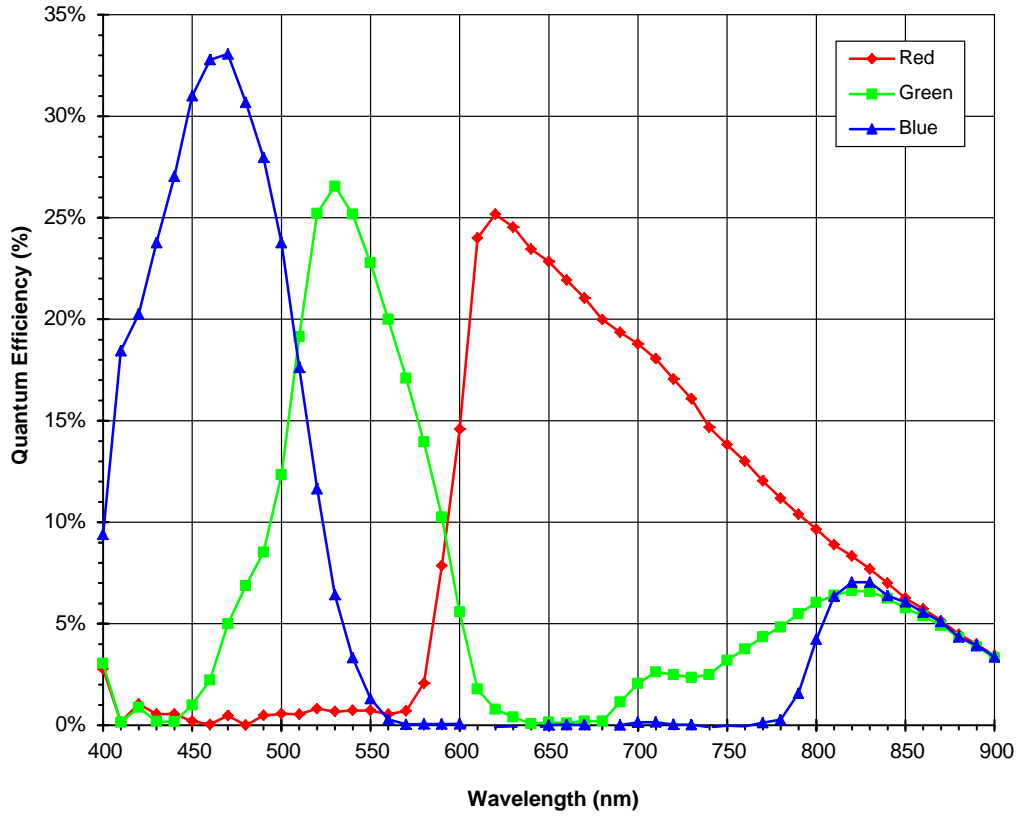

Figure 5. Nominal KAI-0330-CBA Spectral Response

Monochrome with Microlens Quantum Efficiency

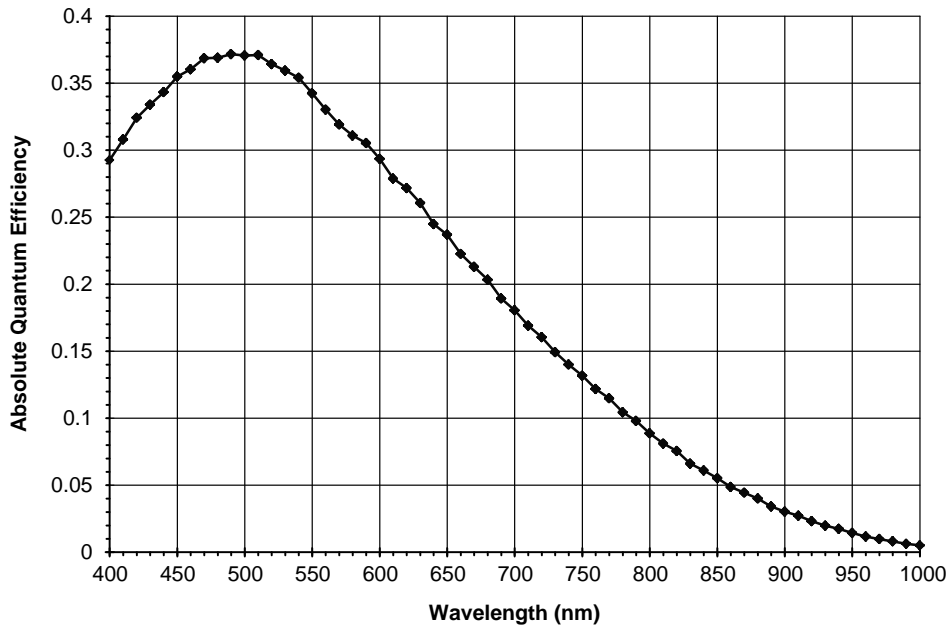

Figure 6. Nominal KAI-0330-ABA Spectral Response

Angular Quantum Efficiency

Monochrome with Microlens

For the curve marked “Horizontal”, the incident light angle is varied in a plane parallel to the HCCD.
 For the curve marked “Vertical”, the incident light angle is varied in a plane parallel to the VCCD.

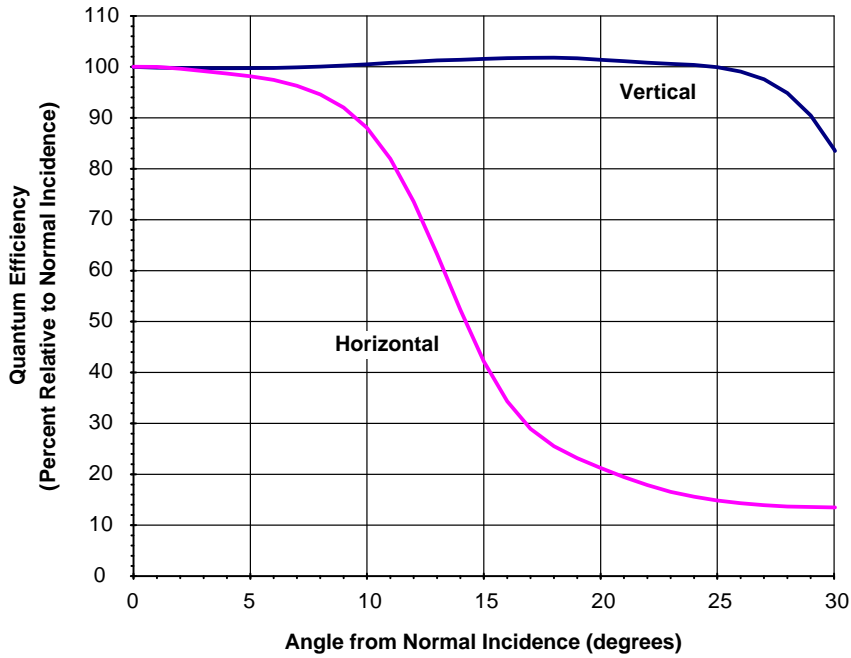

Figure 7. Angular Dependence on Quantum Efficiency

Typical Photoresponse

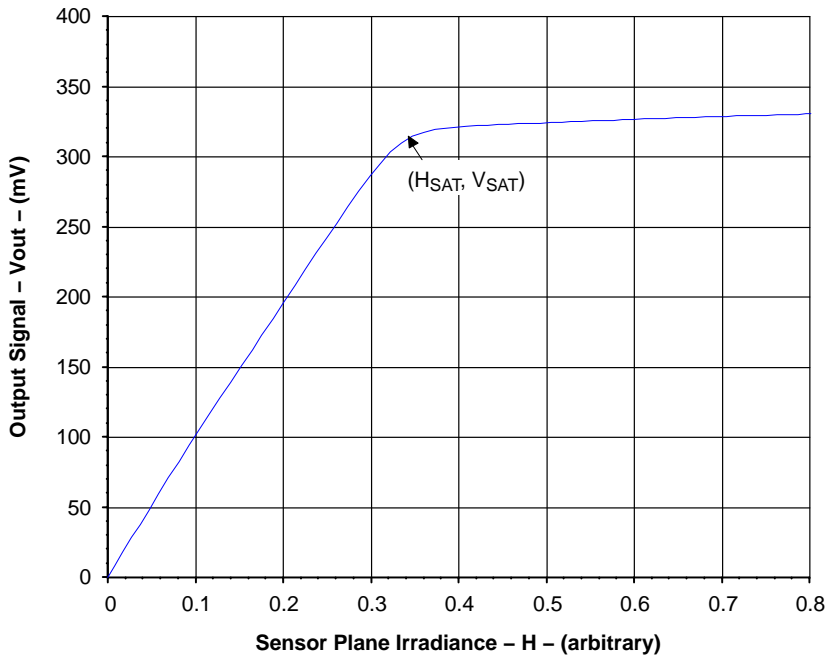

Figure 8. Typical KAI-0330 Photoresponse

Saturation Signal vs. Substrate Voltage

As V_{SUB} is decreased, V_{SAT} increases and anti-blooming protection decreases.
 As V_{SUB} is increased, V_{SAT} decreases and anti-blooming protection increases.

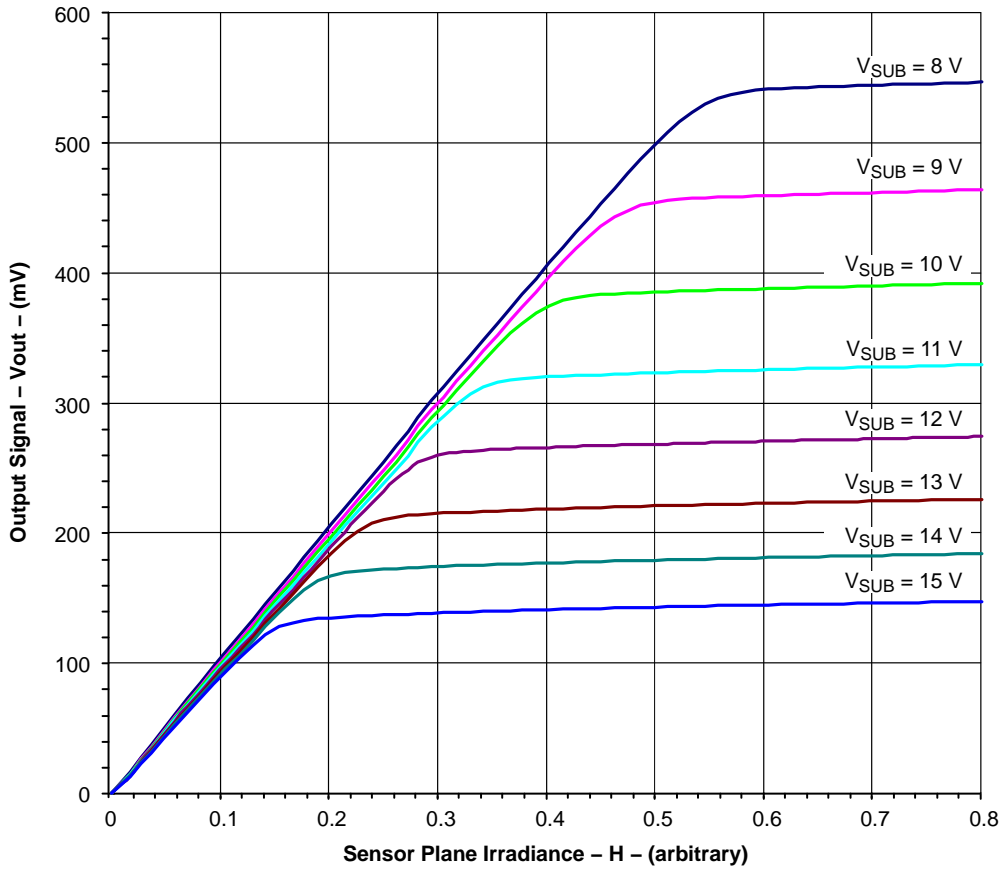

Figure 9. Example of V_{SAT} vs V_{SUB}

Frame Rate

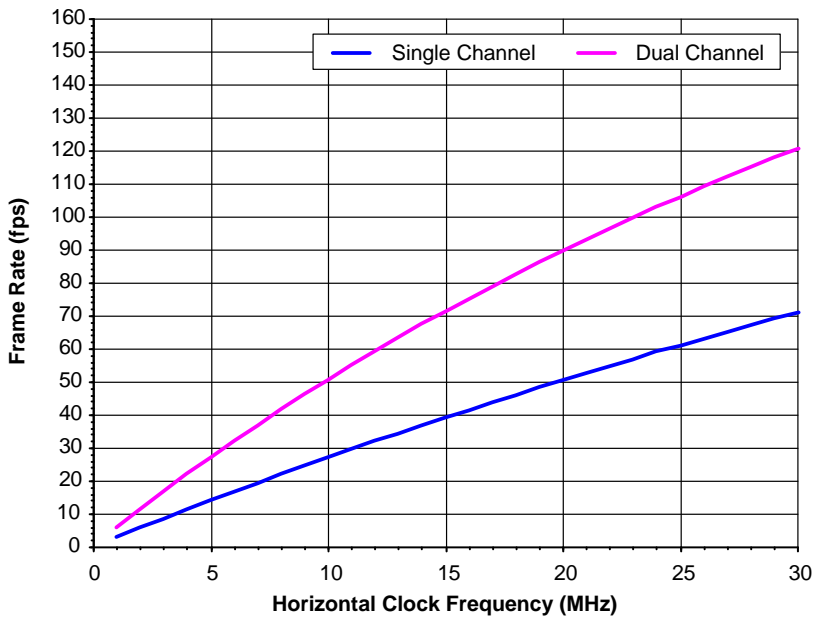

Figure 10. Frame Rate vs. Horizontal Clock Frequency

DEFECT DEFINITIONS

Table 10. OPERATIONAL CONDITIONS

Description	Symbol	Condition
Junction Temperature	T_J	40°C
Integration Time	t_{INT}	40 ms
Readout Rate	$t_{READOUT}$	40 ms

Table 11. SPECIFICATIONS

Point Defects (Major)	Point Defects (Minor)	Cluster Defects	Column Defects
≤ 2	≤ 15	0	0

Table 12. DEFECT DEFINITIONS

Defect Type	Defect Definition
Major Defective Pixel	A pixel whose signal deviates by more than 25 mV from the mean value of all active pixels under dark field condition or by more than 15% from the mean value of all active pixels under uniform illumination at 80% of saturation.
Minor Defective Pixel	A pixel whose signal deviates by more than 6 mV from the mean value of all active pixels under dark field condition.
Point Defect	An isolated defective pixel.
Cluster Defect	A group of 2 to 4 contiguous major defective pixels.
Column Defect	A group of more than 4 contiguous major defective pixels along a single column or row.

NOTE: No row defect are allowed.

OPERATION

Table 13. ABSOLUTE MAXIMUM RATINGS

Rating	Description	Min.	Max.	Unit	Notes
Temperature (@ 10% ±5%RH)	Operation Without Damage	-50	70	°C	
Voltage (Between Pins)	SUB-WELL	0	40	V	1, 5
	V _{RD} , V _{DD} , OG & V _{SS} - WELL	0	15	V	2
	V _{OUTA} & V _{OUTB} - WELL	0	15	V	2
	φV1 - φV2	-12	20	V	2
	φH1A, φH1B - φH2	-12	15	V	2
	φH1A, φH1B, φH2, FDG - φV2	-12	15	V	2
	φH2 - OG & V _{SS}	-12	15	V	2
	φR - SUB	-20	0	V	1, 2, 4
	All Clocks - WELL	-12	15	V	2
Current	Output Bias Current (I _{OUT})	-	10	mA	3

Stresses exceeding those listed in the Maximum Ratings table may damage the device. If any of these limits are exceeded, device functionality should not be assumed, damage may occur and reliability may be affected.

- Under normal operating conditions the substrate voltage should be above +7 V, but may be pulsed to 40 V for electronic shuttering.
- Care must be taken in handling so as not to create static discharge which may permanently damage the device.
- Per Output, I_{OUT} affects the band-width of the outputs.
- φR should never be more positive than V_{SUB}.
- Refer to Application Note *Using Interline CCD Image Sensors in High Intensity Visible Lighting Conditions*.

DC Operating Conditions

Table 14. DC OPERATING CONDITIONS

Description	Symbol	Min.	Nom.	Max.	Unit	Pin Impedance
Reset Drain	V _{RD}	8.5	9	9.5	V	5 pF, > 1.2 MΩ
Reset Drain Current	I _{RD}	-	0.2	-	mA	
Output Amplifier Return & OG	V _{SS}	-	0	-	V	30 pF, > 1.2 MΩ
Output Amplifier Return Current	I _{SS}	-	5	-	mA	
Output Amplifier Supply	V _{DD}	12	15.0	15.5	V	30 pF, > 1.2 MΩ
Output Bias Current (Note 4)	I _{OUT}	-	5	10	mA	
P-Well (Note 1)	WELL	-	0.0	-	V	Common
Ground (Note 1)	GND	-	0.0	-	V	
Fast Dump Gate (Note 2)	FDG	-5.5	-5.0	-4.5	V	20 pF, > 1.2 MΩ
Substrate (Notes 3, 7)	SUB	7	V _{SUB}	15	V	1 nF, > 1.2 MΩ

- The WELL and GND pins should be connected to P-well ground.
- The voltage level specified will disable the fast dump feature.
- This pin may be pulsed to V_{ES} = 40 V for electronic shuttering.
- Per output. Note also that I_{OUT} affects the bandwidth of the outputs.
- Pins shown with impedance greater than 1.2 MΩ are expected resistances. These pins are only verified to 1.2 MΩ.
- The operating levels are for room temperature operation. Operation at other temperatures may or may not require adjustments of these voltages.
- Refer to Application Note *Using Interline CCD Image Sensors in High Intensity Visible Lighting Conditions*.

KAI-0330

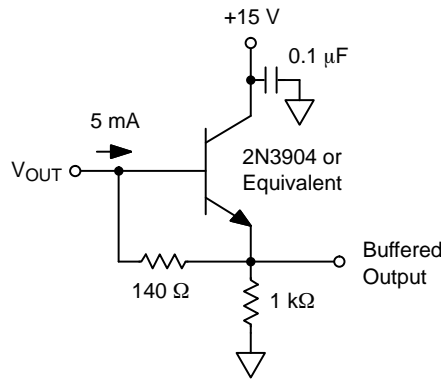

Figure 11. Recommended Output Structure Load Diagram

AC Clock Level Conditions

Table 15. CLOCK LEVELS

Description	Symbol	Level	Min.	Nom.	Max.	Unit	Pin Impedance
Vertical CCD Clock	$\phi V1$	Low	-10.0	-9.5	-9.0	V	25 nF, > 1.2 M Ω
		Mid	0.0	0.2	0.4	V	
		High	8.5	9.0	9.5	V	
Vertical CCD Clock	$\phi V2$	Low	-10.0	-9.5	-9.0	V	25 nF, > 1.2 M Ω
		High	0.0	0.2	0.4	V	
$\phi 1$ Horizontal CCD A Clock	$\phi H1A$	Low	-7.5	-7.0	-6.5	V	100 pF, > 1.2 M Ω
		High	2.5	3.0	3.5	V	
$\phi 1$ Horizontal CCD B Clock (Single Register Mode) (Note 4)	$\phi H1B$	Low	-7.5	-7.0	-6.5	V	100 pF, > 1.2 M Ω
$\phi 1$ Horizontal CCD B Clock (Dual Register Mode) (Note 4)	$\phi H1B$	Low	-7.5	-7.0	-6.5	V	100 pF, > 1.2 M Ω
		High	2.5	3.0	3.5	V	
$\phi 2$ Horizontal CCD Clock	$\phi H2$	Low	-7.5	-7.0	-6.5	V	125 pF, > 1.2 M Ω
		High	2.5	3.0	3.5	V	
Reset Clock	ϕR	Low	-6.5	-6.0	-5.5	V	5 pF, > 1.2 M Ω
		High	-0.5	0.0	0.5	V	
Fast Dump Gate Clock (Note 3)	ϕFDG	Low	-5.5	-5.0	-4.5	V	20 pF, > 1.2 M Ω
		High	4.5	5.0	5.5	V	

1. The AC and DC operating levels are for room temperature operation. Operation at other temperatures may or may not require adjustments of these voltages.
2. Pins shown with impedance greater than 1.2 M Ω are expected resistances. These pins are only verified to 1.2 M Ω .
3. When not used, refer to DC operating condition.
4. For single register mode, set $\phi H1B$ to -7.0 V at all times rather than clocking it.

This device is suitable for a wide range of applications requiring a variety of different operating conditions. Consult

ON Semiconductor in those situations in which operating conditions meet or exceed minimum or maximum levels.

TIMING

Table 16. REQUIREMENTS AND CHARACTERISTICS (For 30 MHz Operation)

Description	Symbol	Min.	Nom.	Max.	Unit	Figure
Reset Pulse Width	$t_{\phi R}$	-	10	-	ns	Figure 14
Electronic Shutter Pulse Width	t_{ES}	10	25	-	μs	Figure 15
Integration Time (Note 1)	t_{INT}	0.1	-	-	ms	Figure 15
Photodiode to VCCD Transfer Pulse Width (Note 2)	$t_{\phi Vh}$	4	5	-	μs	Figure 12
Clamp Delay	t_{CD}	-	15	-	ns	Figure 14
Clamp Pulse Width	t_{CP}	-	15	-	ns	Figure 14
Sample Delay	t_{SD}	-	35	-	ns	Figure 14
Sample Pulse Width	t_{SP}	-	15	-	ns	Figure 14
Vertical Readout Delay	t_{RD}	10	-	-	μs	Figure 12
$\phi V1$, $\phi V2$ Pulse Width	$t_{\phi V}$	2	2.5	-	μs	Figure 13
$\phi H1A$, $\phi H1B$, $\phi H2$	Clock Frequency $t_{\phi H}$	-	-	30	MHz	Figure 14
Line A to Line B Transfer Pulse Width	$t_{\phi AB}$	2	2.5	-	μs	Figure 17
Horizontal Delay	$t_{\phi Hd}$	2	2.5	-	μs	Figure 13
Vertical Delay	$t_{\phi Vd}$	25	-	-	ns	Figure 13
Horizontal Delay with Electronic Shutter	$t_{\phi HVES}$	1	-	-	μs	Figure 15

- Integration time varies with shutter speed. It is to be noted that smear increases when integration time decreases below readout time (frame time). Photodiode dark current increases when integration time increases, while CCD dark current increases with readout time (frame time).
- Anti-blooming function is off during photodiode to VCCD transfer.

Frame Timing – Single Register Readout

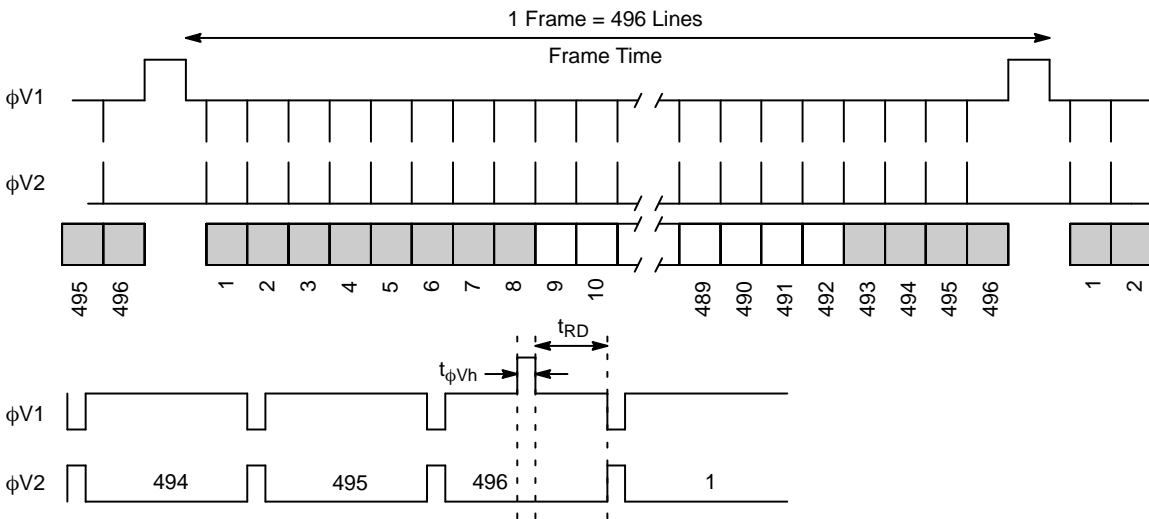

NOTE: When no electronic shutter is used, the integration time is equal to the frame time.

Figure 12. Frame Timing Diagram – Single Register Readout

Line Timing – Single Register Readout

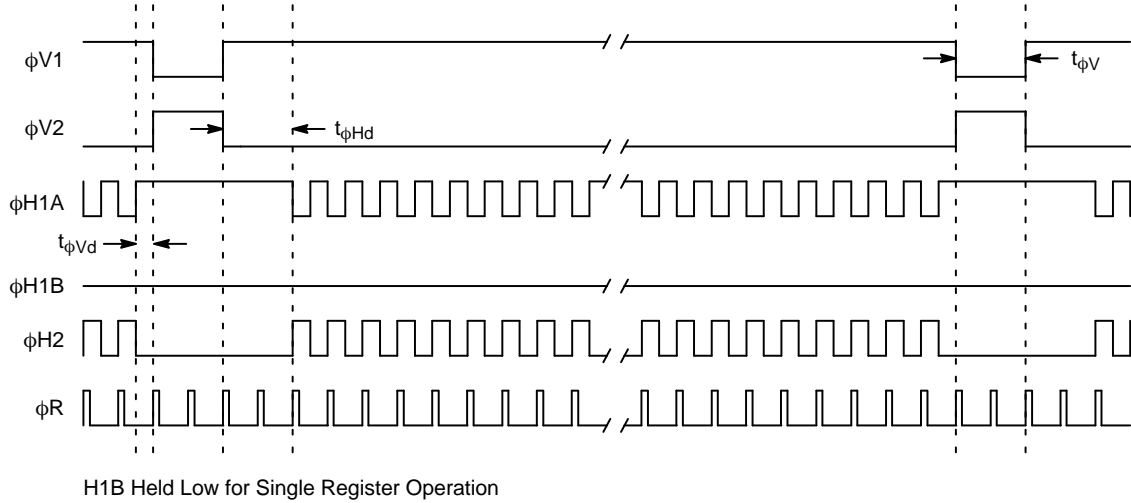

Line Content



Figure 13. Line Timing Diagram – Single Register Output

Pixel Timing – Single Register Readout

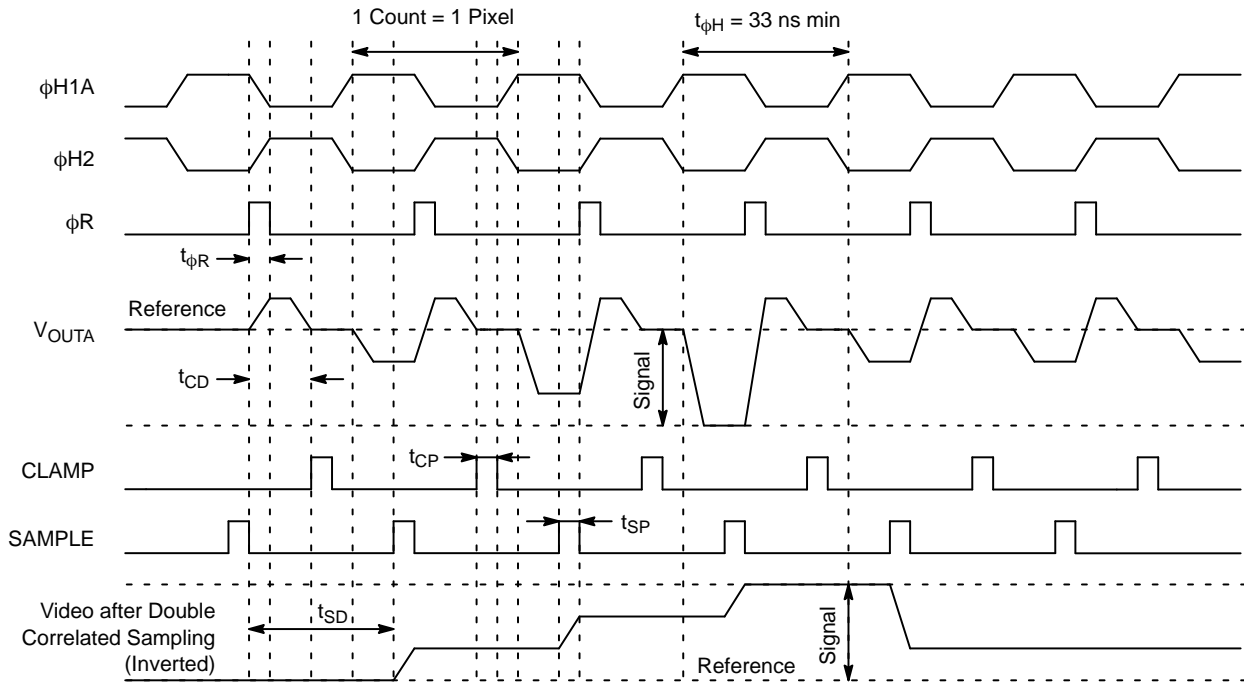
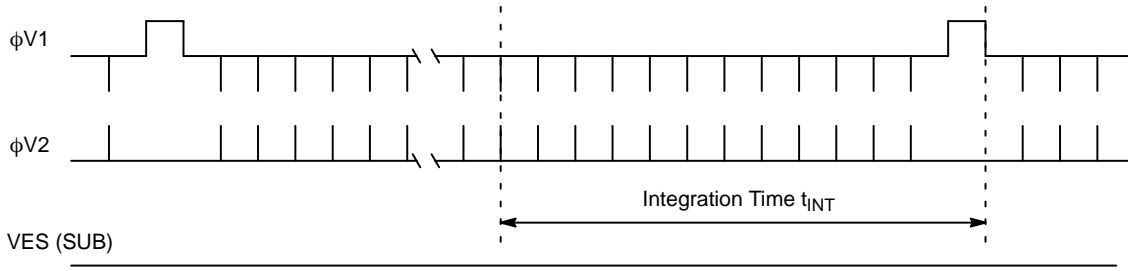

Figure 14. Pixel Timing Diagram – Single Register Readout

Electronic Shutter Timing – Single Regulator Readout

Frame Timing



Placement

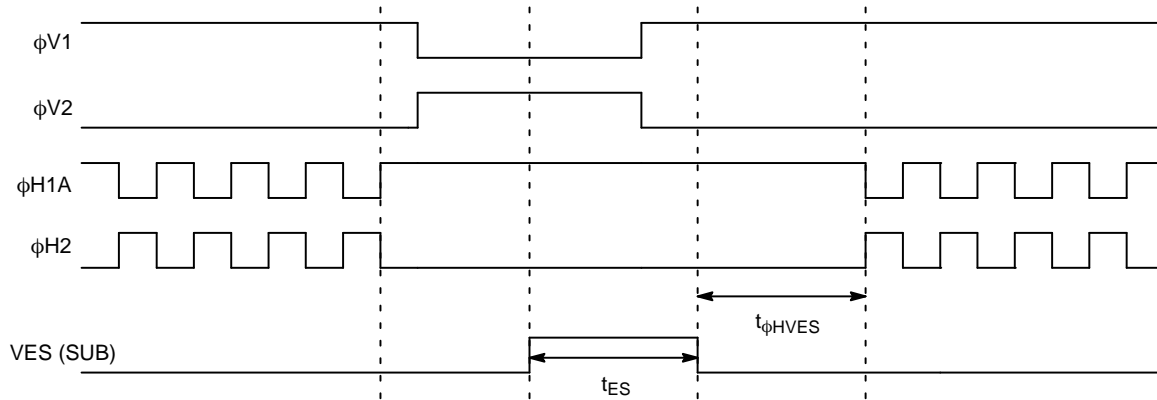

Operating Voltages

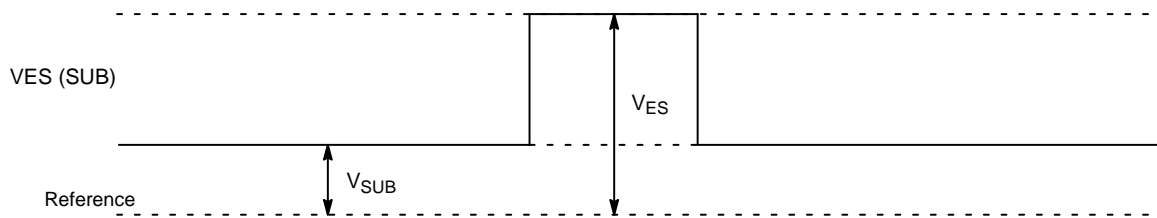
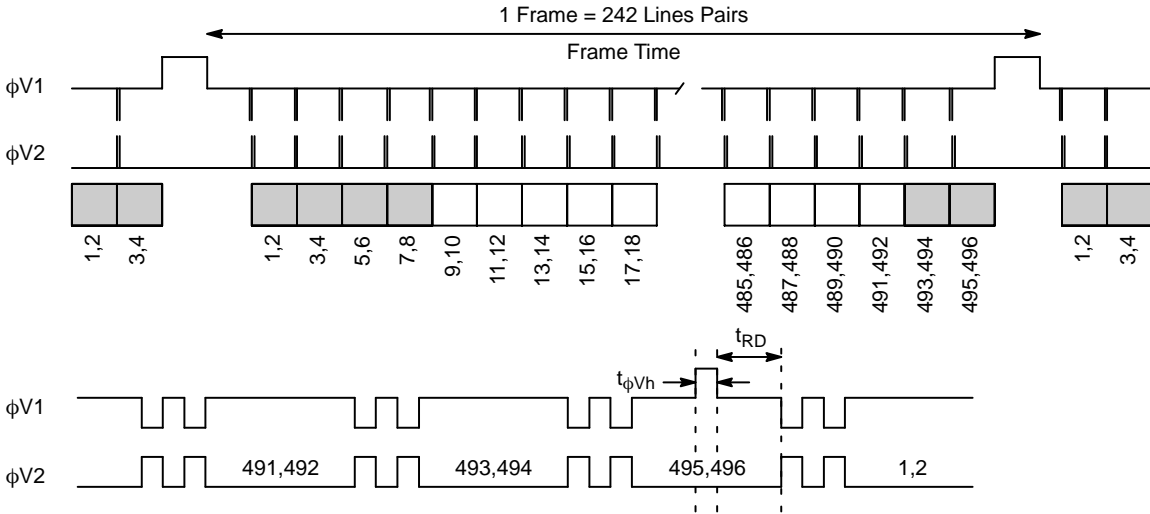

Figure 15. Electronic Shutter Timing Diagram – Single Register Readout

Frame Timing – Dual Register Readout



NOTE: When no electronic shutter is used, the integration time is equal to the frame time.

Figure 16. Frame Timing Diagram – Dual Register Readout

Line Timing – Dual Register Readout

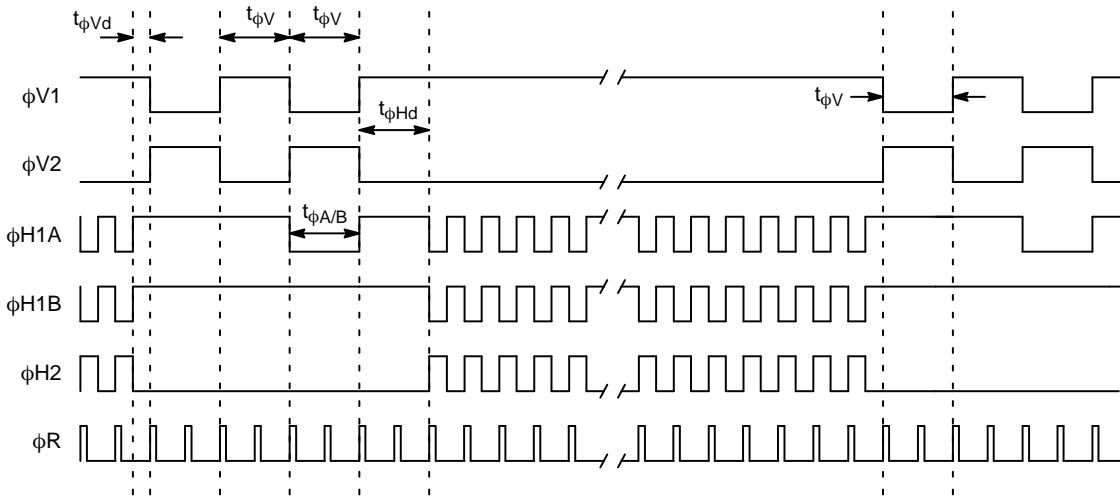

Line Content

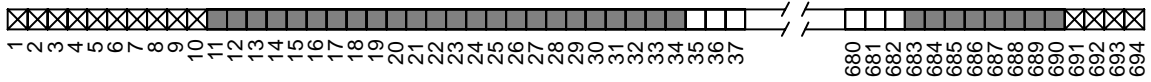

Empty Shift Register Phases
 Dark Reference Pixels
 Photoactive Pixels

Figure 17. Line Timing Diagram – Dual Register Output

Pixel Timing – Dual Register Readout

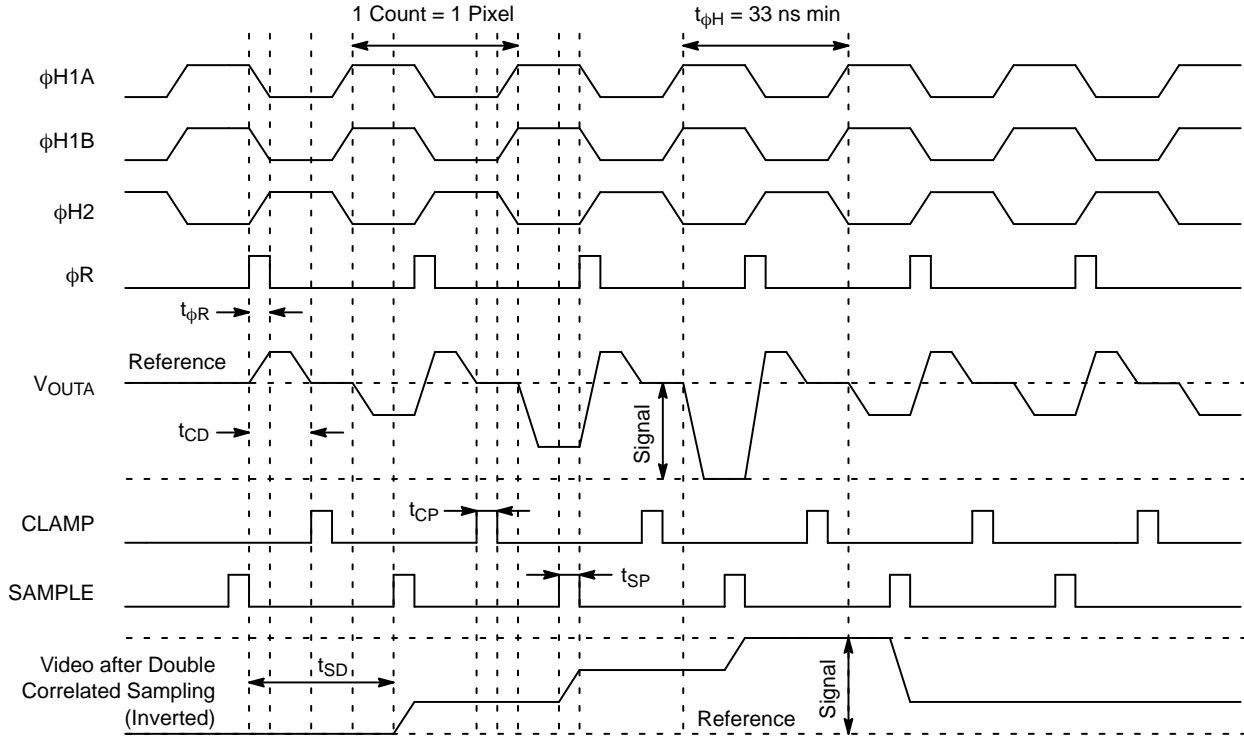

Figure 18. Pixel Timing Diagram – Dual Register Readout

Fast Line Dump Timing – Removing Four Lines

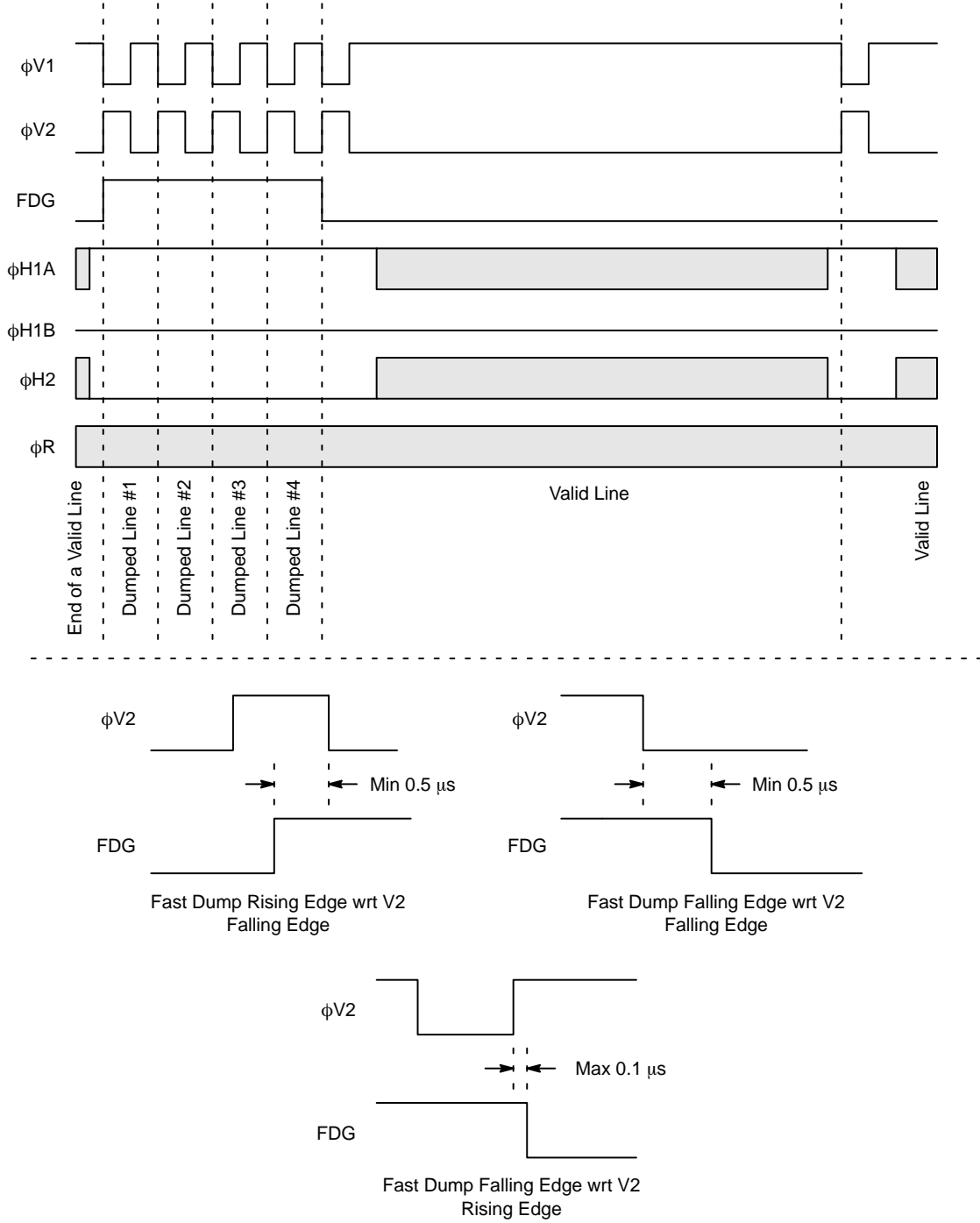

Figure 19. Fast Line Dump Timing – Removing Four Lines

Binning – Two to One Line Binning

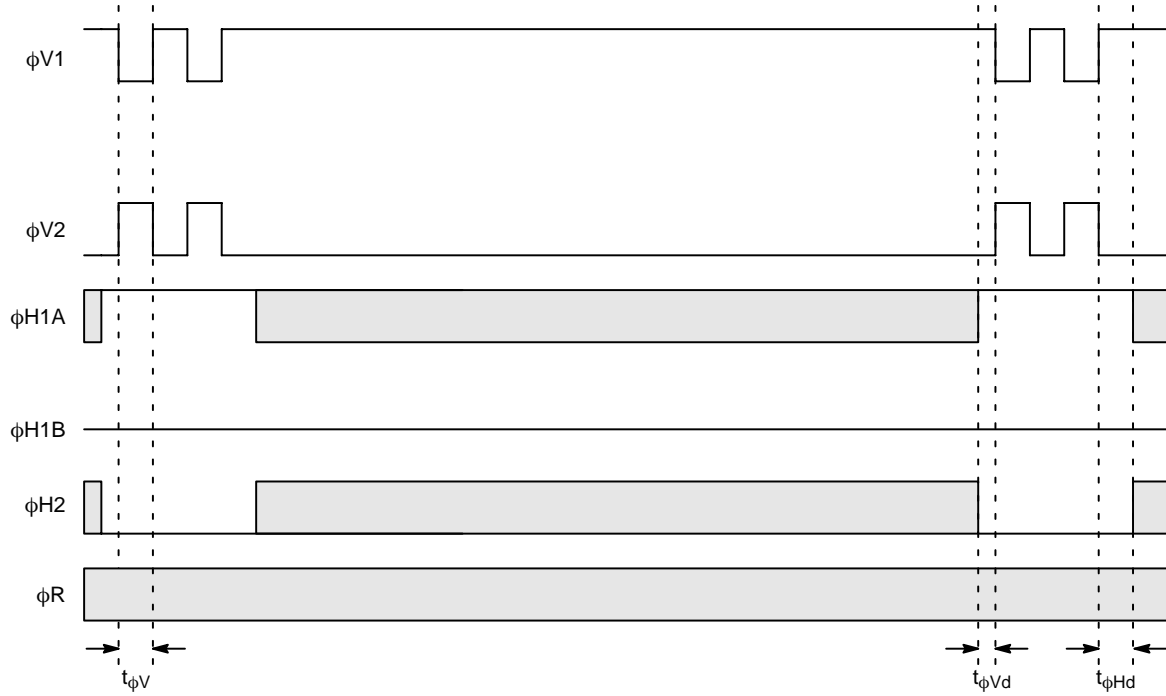

Figure 20. Binning – 2 to 1 Line Binning

Timing – Sample Video Waveform

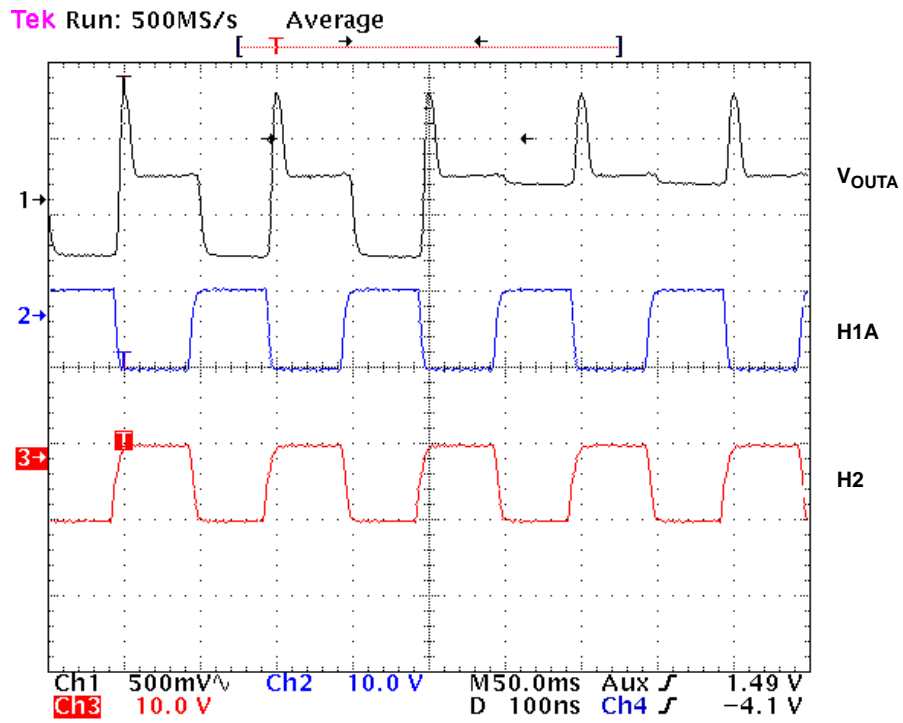

Figure 21. Sample Video Waveform at 5 MHz

STORAGE AND HANDLING

Table 17. CLIMATIC REQUIREMENTS

Item	Description	Min.	Max.	Units	Conditions	Notes
Operation to Specification	Temperature	-25	40	°C	@ 10% ±5% RH	1, 2
	Humidity	10±5	86±5	% RH	@ 36±2°C Temp.	1, 2
Storage	Temperature	-55	70	°C	@ 10% ±5% RH	2, 4
	Humidity	-	95±5	% RH	@ 49±2°C Temp.	2, 4

1. The image sensor shall meet the specifications of this document while operating at these conditions.
2. The tolerance on all relative humidity values is provided due to limitations in measurement instrument accuracy.
3. The image sensor shall continue to function but not necessarily meet the specifications of this document while operating at the specified conditions.
4. The image sensor shall meet the specifications of this document after storage for 15 days at the specified conditions.

For information on ESD and cover glass care and cleanliness, please download the *Image Sensor Handling and Best Practices* Application Note (AN52561/D) from www.onsemi.com.

For information on environmental exposure, please download the *Using Interline CCD Image Sensors in High Intensity Lighting Conditions* Application Note (AND9183/D) from www.onsemi.com.

For information on soldering recommendations, please download the *Soldering and Mounting Techniques Reference Manual* (SOLDERRM/D) from www.onsemi.com.

For quality and reliability information, please download the *Quality & Reliability Handbook* (HBD851/D) from www.onsemi.com.

For information on device numbering and ordering codes, please download the *Device Nomenclature* technical note (TND310/D) from www.onsemi.com.

For information on Standard terms and Conditions of Sale, please download [Terms and Conditions](http://www.onsemi.com) from www.onsemi.com.

MECHANICAL INFORMATION

Completed Assembly

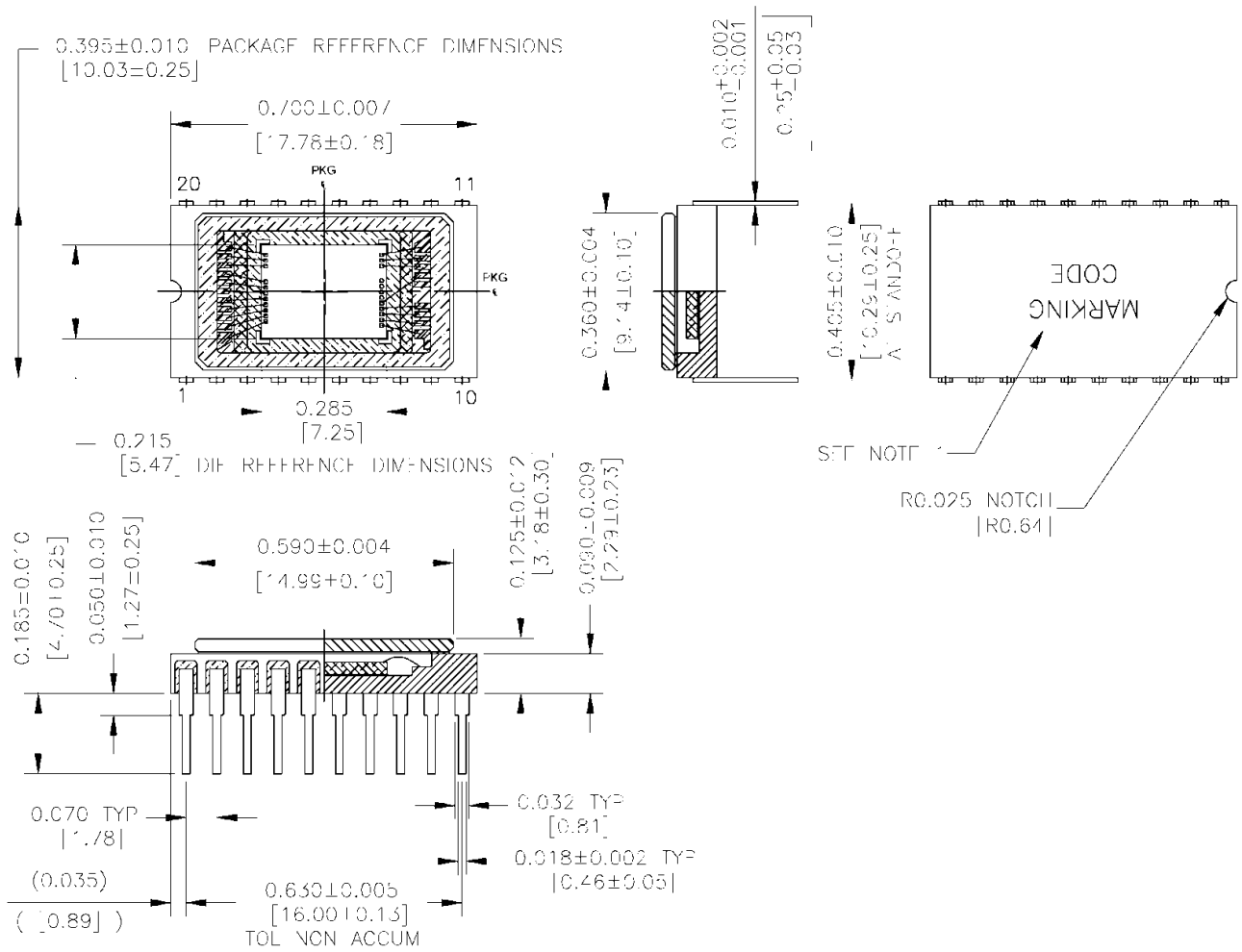

Notes:

1. See Ordering Information for Marking Code.
2. Cover Glass is visually aligned over die – location accuracy is not guaranteed.
3. Units: Inches [mm].

Figure 22. Completed Assembly (1 of 2)

KAI-0330

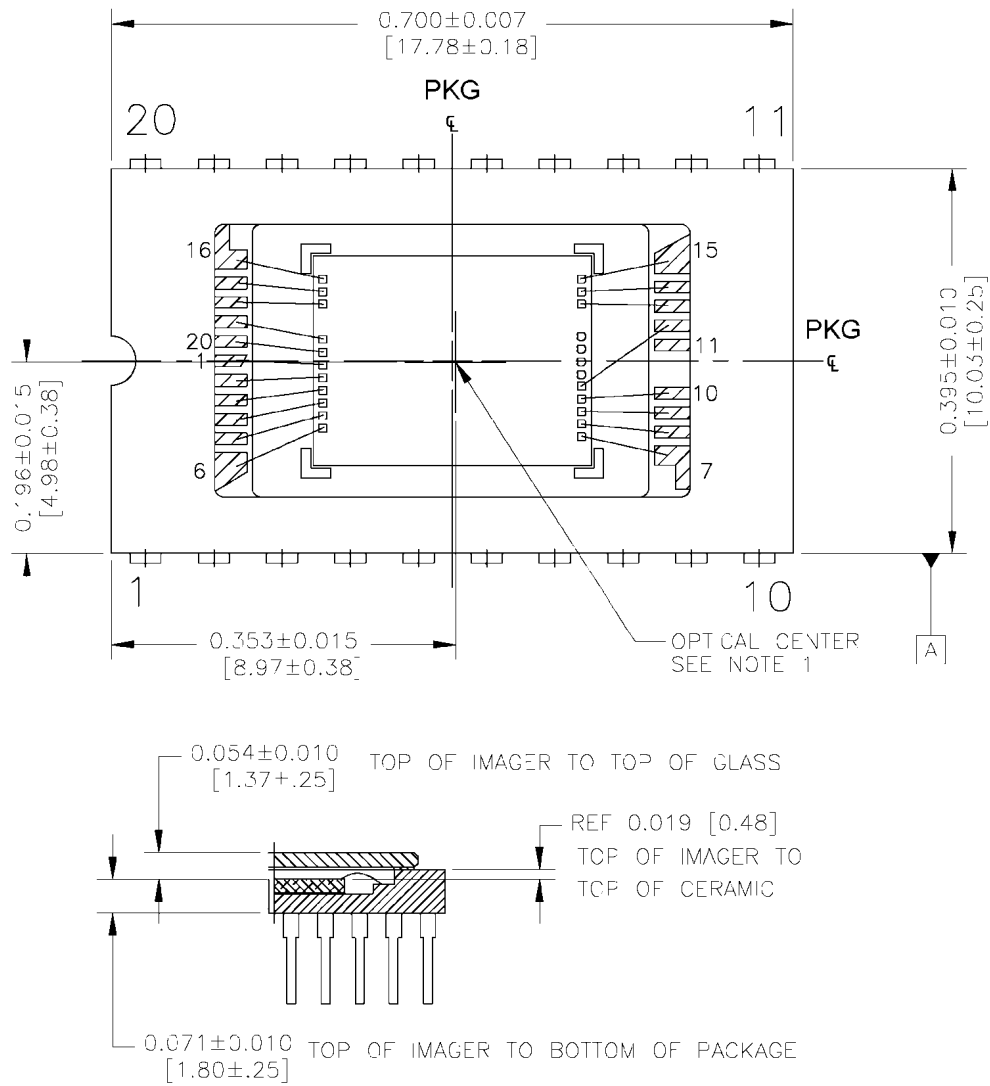

Notes:

1. Center of image area is offset from center of package by (0.08, -0.04) mm nominal.
2. Die is visually aligned within $\pm 2^\circ$ of datum A.
3. Units: Inches [mm].

Figure 23. Completed Assembly (2 of 2)

KAI-0330

Cover Glass

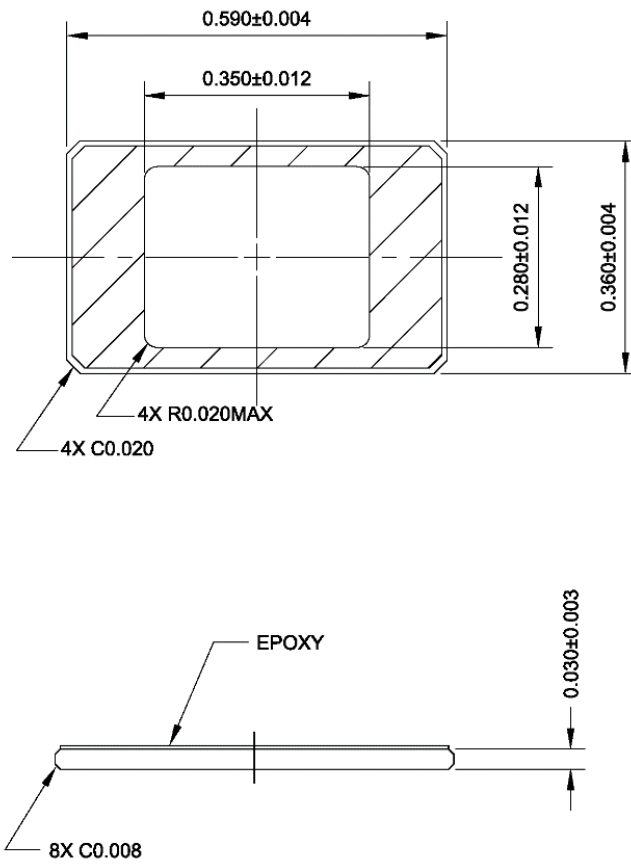

Notes:

1. Dust/Scratch Count: 5 microns max
2. Units: Inches

Figure 24. Cover Glass Drawing

Cover Glass Transmission

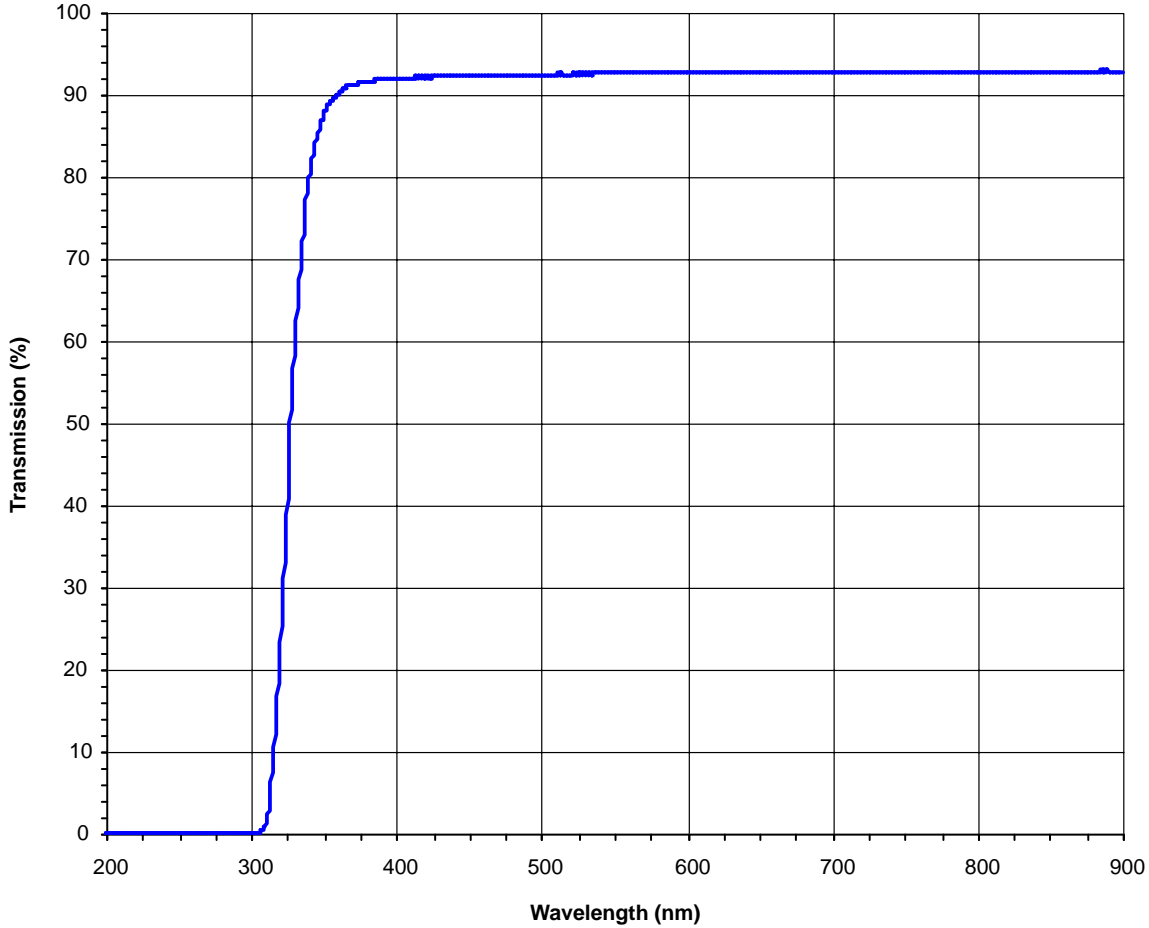



Figure 25. Cover Glass Transmission

ON Semiconductor and the  are registered trademarks of Semiconductor Components Industries, LLC (SCILLC) or its subsidiaries in the United States and/or other countries. SCILLC owns the rights to a number of patents, trademarks, copyrights, trade secrets, and other intellectual property. A listing of SCILLC's product/patent coverage may be accessed at www.onsemi.com/site/pdf/Patent-Marking.pdf. SCILLC reserves the right to make changes without further notice to any products herein. SCILLC makes no warranty, representation or guarantee regarding the suitability of its products for any particular purpose, nor does SCILLC assume any liability arising out of the application or use of any product or circuit, and specifically disclaims any and all liability, including without limitation special, consequential or incidental damages. "Typical" parameters which may be provided in SCILLC data sheets and/or specifications can and do vary in different applications and actual performance may vary over time. All operating parameters, including "Typicals" must be validated for each customer application by customer's technical experts. SCILLC does not convey any license under its patent rights nor the rights of others. SCILLC products are not designed, intended, or authorized for use as components in systems intended for surgical implant into the body, or other applications intended to support or sustain life, or for any other application in which the failure of the SCILLC product could create a situation where personal injury or death may occur. Should Buyer purchase or use SCILLC products for any such unintended or unauthorized application, Buyer shall indemnify and hold SCILLC and its officers, employees, subsidiaries, affiliates, and distributors harmless against all claims, costs, damages, and expenses, and reasonable attorney fees arising out of, directly or indirectly, any claim of personal injury or death associated with such unintended or unauthorized use, even if such claim alleges that SCILLC was negligent regarding the design or manufacture of the part. SCILLC is an Equal Opportunity/Affirmative Action Employer. This literature is subject to all applicable copyright laws and is not for resale in any manner.

PUBLICATION ORDERING INFORMATION

LITERATURE FULFILLMENT:
 Literature Distribution Center for ON Semiconductor
 19521 E. 32nd Pkwy, Aurora, Colorado 80011 USA
Phone: 303-675-2175 or 800-344-3860 Toll Free USA/Canada
Fax: 303-675-2176 or 800-344-3867 Toll Free USA/Canada
Email: orderlit@onsemi.com

N. American Technical Support: 800-282-9855 Toll Free
 USA/Canada
Europe, Middle East and Africa Technical Support:
 Phone: 421 33 790 2910
Japan Customer Focus Center
 Phone: 81-3-5817-1050

ON Semiconductor Website: www.onsemi.com
Order Literature: <http://www.onsemi.com/orderlit>
 For additional information, please contact your local Sales Representative