

- 1. APPLICATORS 91411-1 AND -2 ARE DESIGNED FOR MANUAL OPERATION. USE ARBOR FRAME ASS'Y, P/N 91085-2.
- 2 FOR PNEUMATIC OPERATION, AUTO-CYCLE FRAME ASS'Y, P/N 91112-2, SEE PNEUMATIC CONVERSION KIT, P/N 527145-1
- 3 FOR SINGLE ROW CONVERSION, SEE KIT P/N 527133
- 4 FOR DISCRETE WIRE APPLICATION, SEE KIT P/N 527085
- △ PIN, P/N 527122-1 ITEM 4, TO BE PRESS IN TO PLATE
- ▽ MARKING PER AMP SPEC 115-67-2.

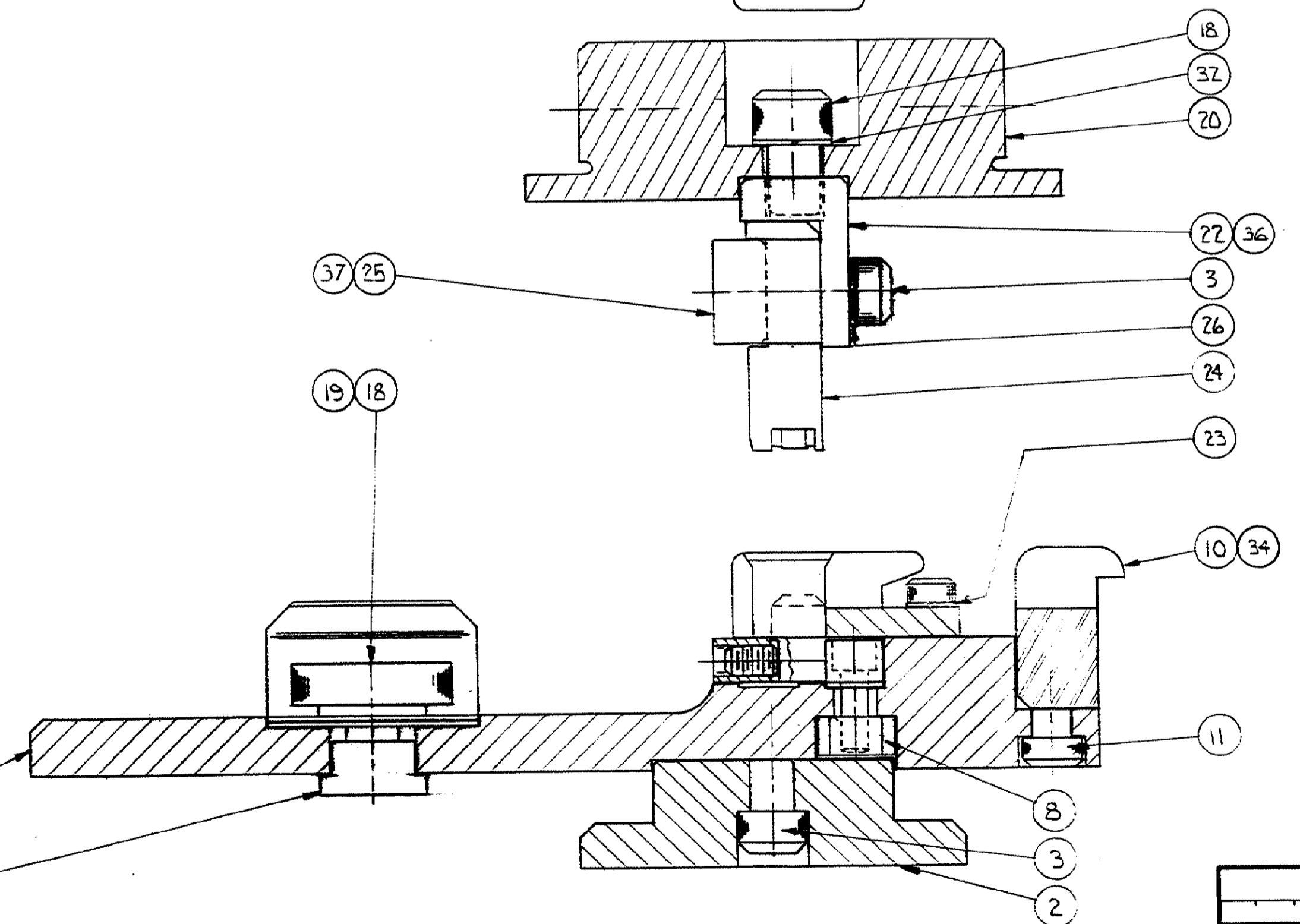
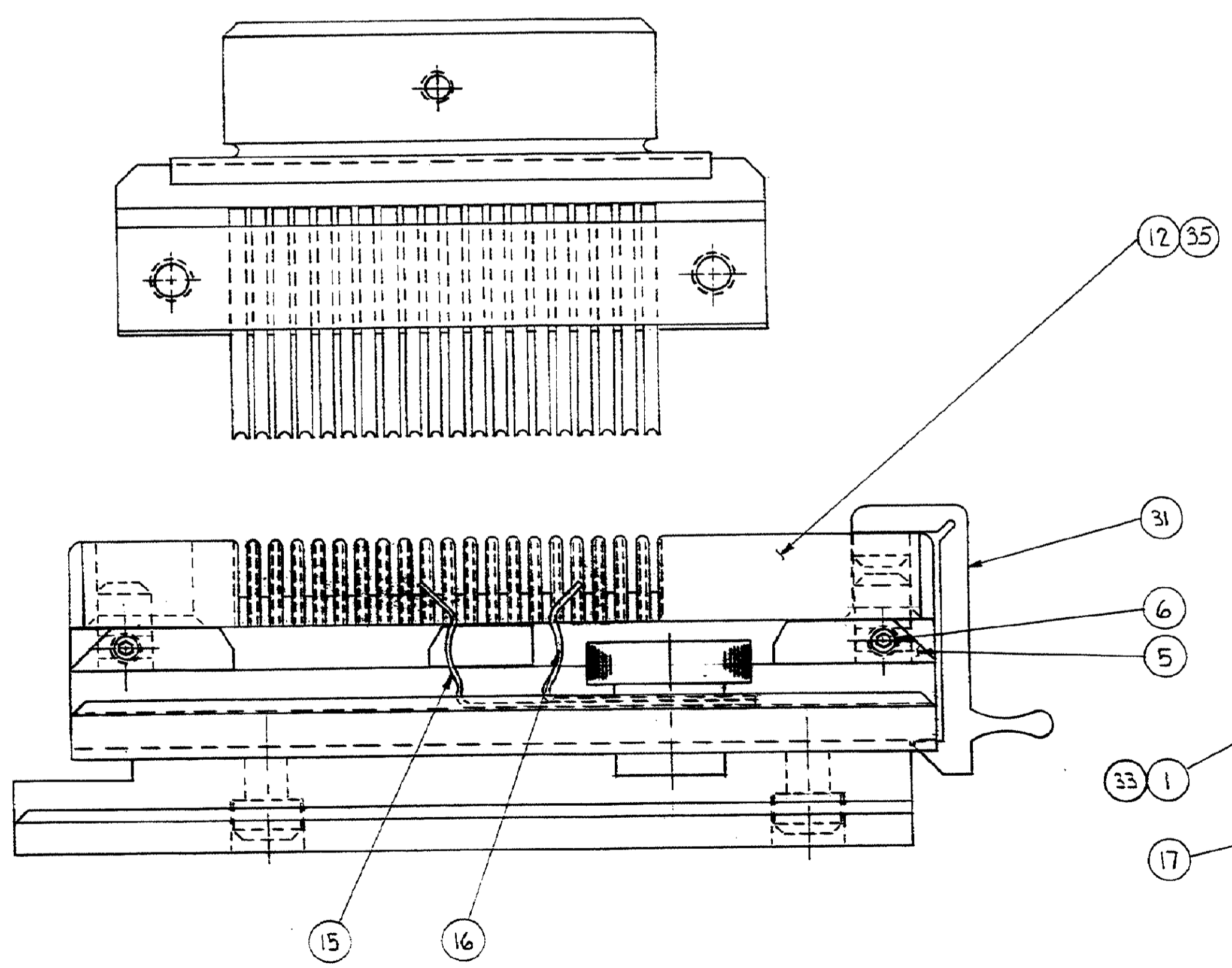
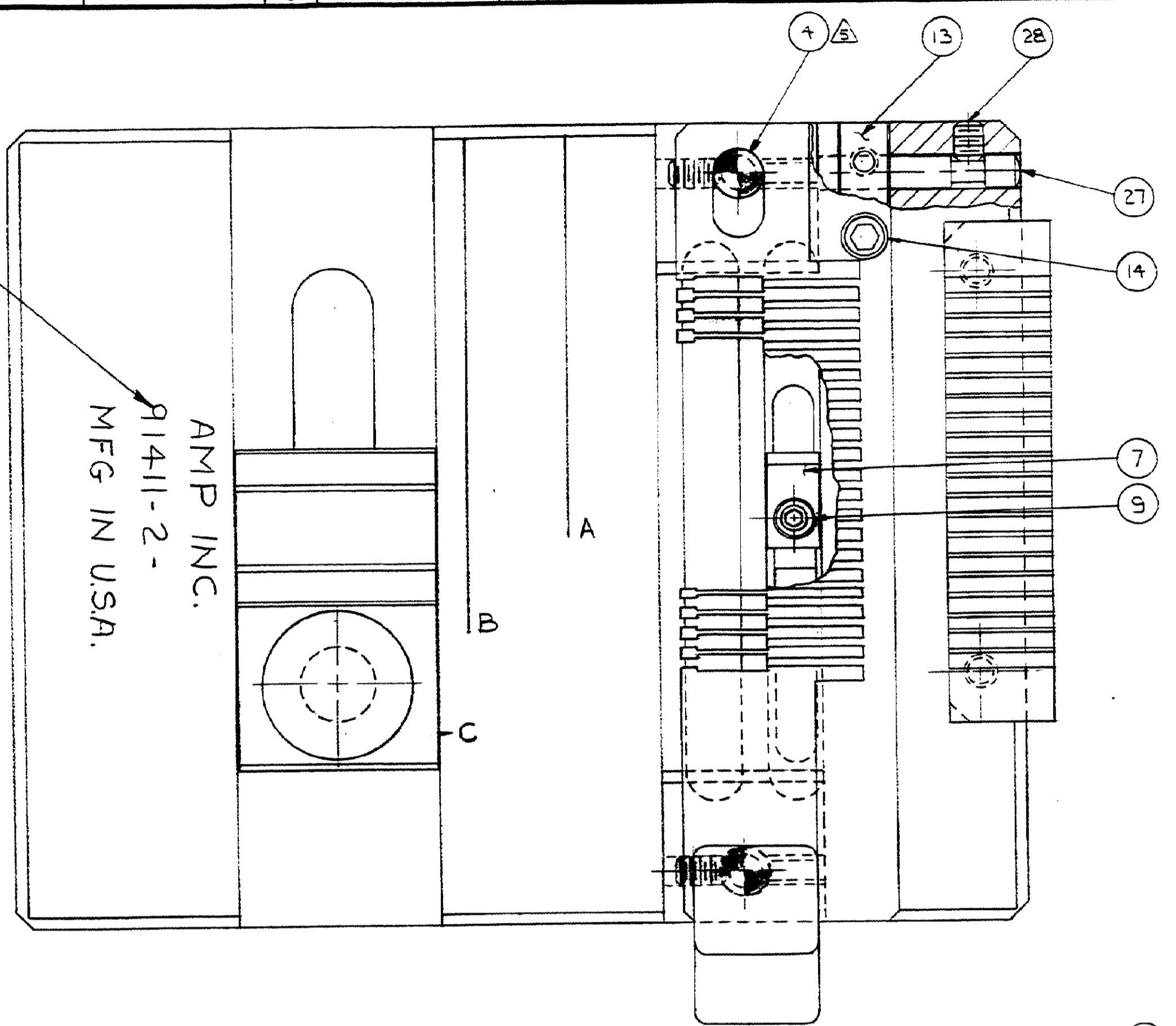

SUPPLD BY 91411-2

QTY	REF	PART NO	DESCRIPTION	ITEM
1	A	527130-2	HOLDER, INSERTER 25	37
1	A	527128-2	HOLDER, UPPER TOOLING 25	36
1	C	527127-2	SHEAR BAR/WIRE COMB 25	35
1	B	527126-2	COMB, WIRE	34
1	D	527120-2	PLATE, BASE (MT APPL) 25	33
1	A	21024-6	WASHER, SPRING LOC 1/4	32
1	B	527147-1	LATCH, HINGE	31
				30
				29
1	A	2-21010-8	SCREW, #6-32x.19 SOC SET	28
1	A	527144-1	PIN, PIVOT	27
2	A	21024-5	WASHER, SPRING-LOC #10	26
1	A	527130-1	HOLDER, INSERTER 20	25
25	B	527129-1	INSERTER	24
2	A	21024-3	WASHER, SPRING-LOC #6	23
1	A	527128-1	HOLDER, UPPER TOOLING 20	22
				21
1	A	527146-1	TOOL MOUNT (MANUAL)	20
1	A	27708-5	THUMB SCREW SHEAR-LOC	19
2	A	21001-1	SCREW, #4-20x.38 SOC HD CAP	18
1	A	527137-1	NUT, SLIDE, CABLE CLAMP	17
1	B	527135-1	SPRING, CABLE CLAMP - TOP	16
1	B	527134-1	SPRING, CABLE CLAMP - BOTTOM	15
2	A	1-21000-8	SCREW, #6-32x.25 SOC HD. CAP	14
1	A	527143-1	PLATE, PIVOT	13
1	C	527127-1	SHEAR BAR - WIRE COMB 20	12
2	A	2-21000-6	SCREW, #8-32x.38 SOC HD. CAP	11
1	B	527126-1	COMB, WIRE 20	10
1	A	1-21000-4	SCREW, #4-40x.38 SOC HD. CAP	9
1	A	527125-1	NUT, SLIDE	8
1	A	527124-1	LOCATOR, CONNECTOR (OBL ROW)	7
2	A	2-21010-9	SCREW, #6-32x.25 SOC SET	6
2	A	527123-1	SPACER, STOP	5
2	A	527122-1	PIN, SHEAR WIRE COMB LOCATOR	4
4	A	3-21000-5	SCREW, #10-32x.50, SOC HD. CAP	3
1	B	527121-1	SLIDE, BASE (MT APPL)	2
1	D	527120-1	PLATE, BASE (MT APPL) 20	1

THIS INFORMATION IS CONFIDENTIAL AND IS DISCLOSED TO YOU ON CONDITION THAT YOU WILL NOT DISCLOSE IT TO OTHER THAN AMP PERSONNEL WITHOUT WRITTEN AUTHORIZATION FROM AMP INCORPORATED, HARRISBURG, PA.

LOC A
DIST 4

QTY REQD PER ASSY		PARTS LIST	
DWG SIZE	PART NO	DESCRIPTION	ITEM
D		REVISION OF EACH ASSY NO (WHEN BLANK, USE DWG REVISION)	
DIMENSIONS IN INCHES. TOLERANCES UNLESS OTHERWISE SPECIFIED:		MATERIAL	HEAT TREAT
2 PL DEC ±		FINISH	
3 PL DEC ±		AMP INCORPORATED	
4 PL DEC ±		HARRISBURG, PA.	
ANGLES ±		NAME MASS TERMINATION BENCH APPLICATOR (MT SERIES)	
SURF TEXTURE: ✓		SCALE 2-1	DWG NO 91411
REMOVE BURRS, BREAK SHARP EDGES .01SR MAX		SHEET 181	REV D