

4

3

2

DWG NO.	SH	REV
GE-2156	1	C

1

PROPRIETARY NOTICE: THE INFORMATION CONTAINED IN THIS DOCUMENT IS PROPRIETARY TO AMPHENOL AND SHALL NOT BE DISCLOSED IN WHOLE OR IN PART IN ANY FORM OR FOR ANY REASON EXCEPT AS EXPRESSLY STATED IN WRITING BY AMPHENOL.

NOTES:

1. CONTINUOUS OPERATING TEMPERATURE -40°C TO 150°C
2. CONNECTOR: METRI-PACK 150.2 OR GT150 3.5mm ϕ MATING APTIV(DEPLHI) NUMBER: 12162193,15336004, OR EQUIVILANT
3. VOLTAGE: 5V
4. NEEDS A SEALING GASKET, A COPPER CRUSH WASHER OR POSSIBLY AN O-RING.
5. RECOMENDED INSTALLATION TORQUE OF 25 NM, REFERENCE.

TEMP (°C)	RESISTANCE (OHMS)	RES TOL (±%)
-40	100865	4.87
25	2795	2.50
50	980.3	2.27
85	283.5	2.00
125	88.3	2.75
128	81.7	2.77
150	47.5	2.90

REVISIONS				
REV	REVISION HISTORY	DATE	DWN	APVD
A	INITIAL RELEASE	05/31/18	MED	JD
B	85°C WAS 80°C ADDED 128°C ROW	11/01/18	MED	JD
C	UP-DATED NOTES, 28.6+/- .5 WAS 28.60, ULTEM 2300 BLACK WAS NYLON 66 GF 33%	05/30/19	MED	STS

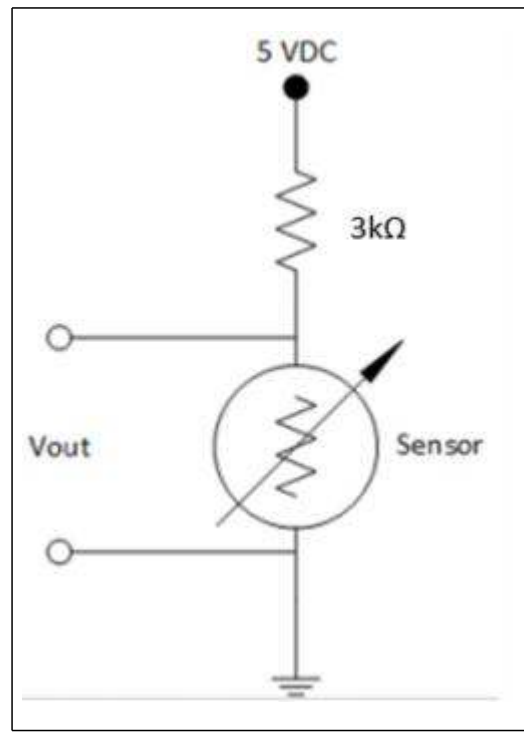

TYPICAL, 25°C CIRCUIT

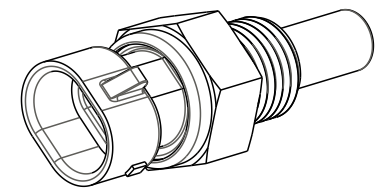
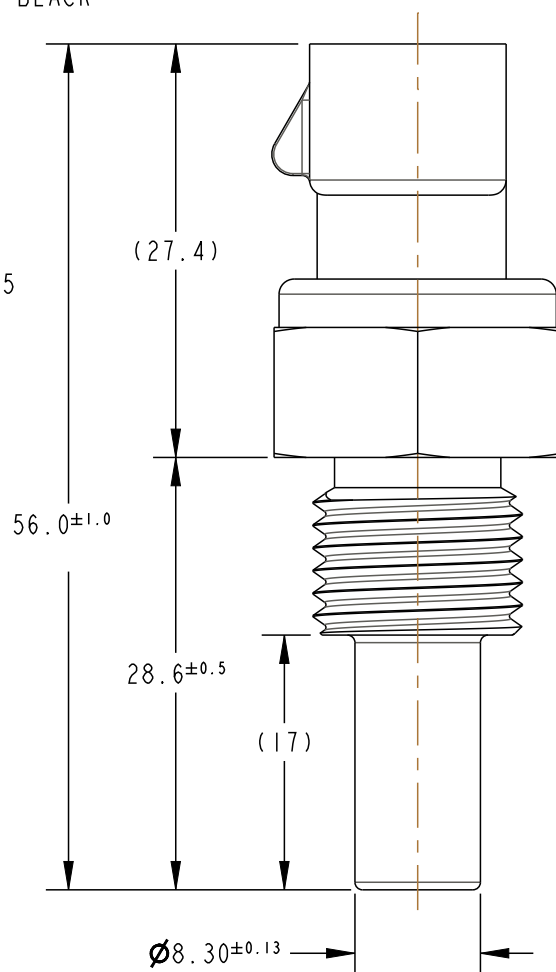
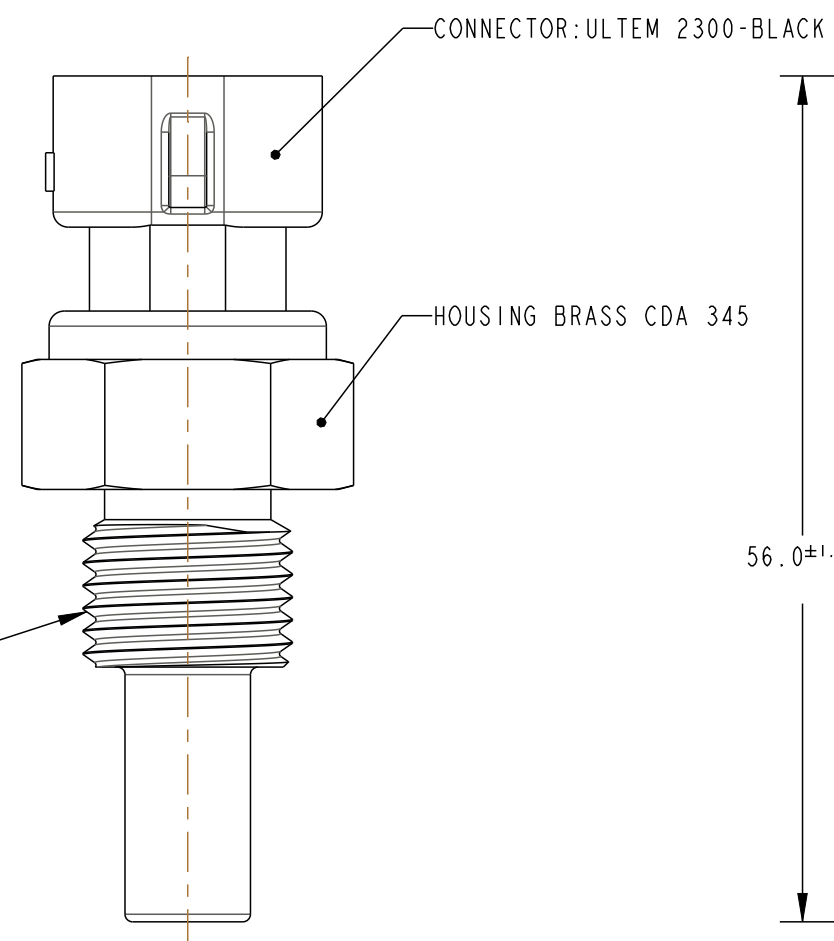
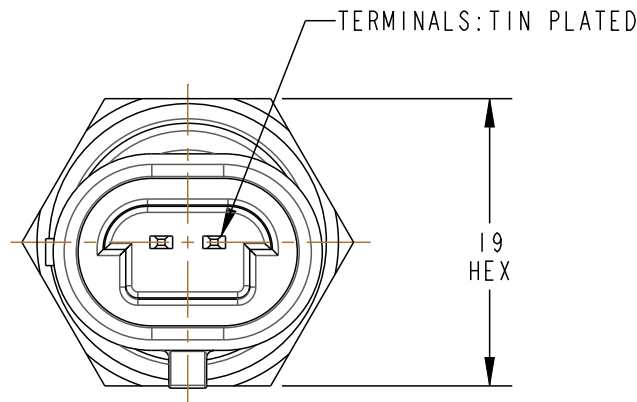

SCALE 1:1

Amphenol
Advanced Sensors St. Marys, PA 15857

TITLE: FLUID TEMPERATURE SENSOR

UNLESS OTHERWISE SPECIFIED DIMENSIONS ARE IN MM TOLERANCES ARE: .X ± 0.5 .XX ± 0.25	APPROVALS	DATE
	DRAWN DAM/MED	05/31/18
THIRD ANGLE PROJECTION	CHECKED STS	05/31/18
	ENGR JJD	05/31/18
INTERPRET DRAWING IAW ASME Y14.5	OC	
MATERIAL SEE DRAWING	MFG	

DO NOT SCALE DRAWING

SIZE B DWG NO. GE-2156 REV C

SCALE 1:1 SHEET 1 OF 1

LEGAL NOTICE - THIS DRAWING AND ANY INTELLECTUAL PROPERTY RIGHTS THERE IN ARE PROPERTY OF AMPHENOL AND NO LICENSES ARE GRANTED UNDER THOSE RIGHTS

4

3

2

1