

THIS DRAWING IS UNPUBLISHED. RELEASED FOR PUBLICATION - .N/A .
 © COPYRIGHT N/A BY TYCO ELECTRONICS CORPORATION. ALL RIGHTS RESERVED.

LOC	DIST	REVISIONS					
DF	SO	P	LTR	DESCRIPTION	DATE	DWN	APVD
		B		REV PER 0H14-0191-05	05-05	AA	DE

1. RECEPTACLE WILL MATE WITH ANY LGH-1/4 LEAD ASSEMBLY.
2. RATING: 5KVDC (7.5 KVDC DWV)
0 TO 70,000 FEET ALTITUDE
-55°C TO +125°C

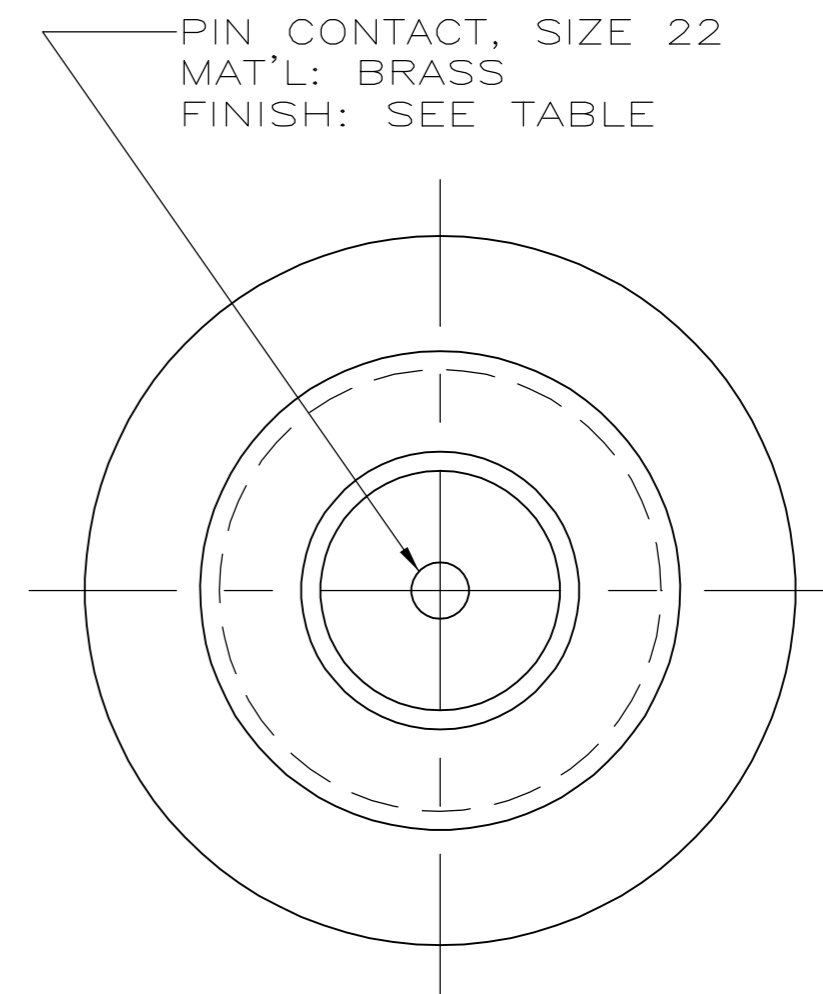
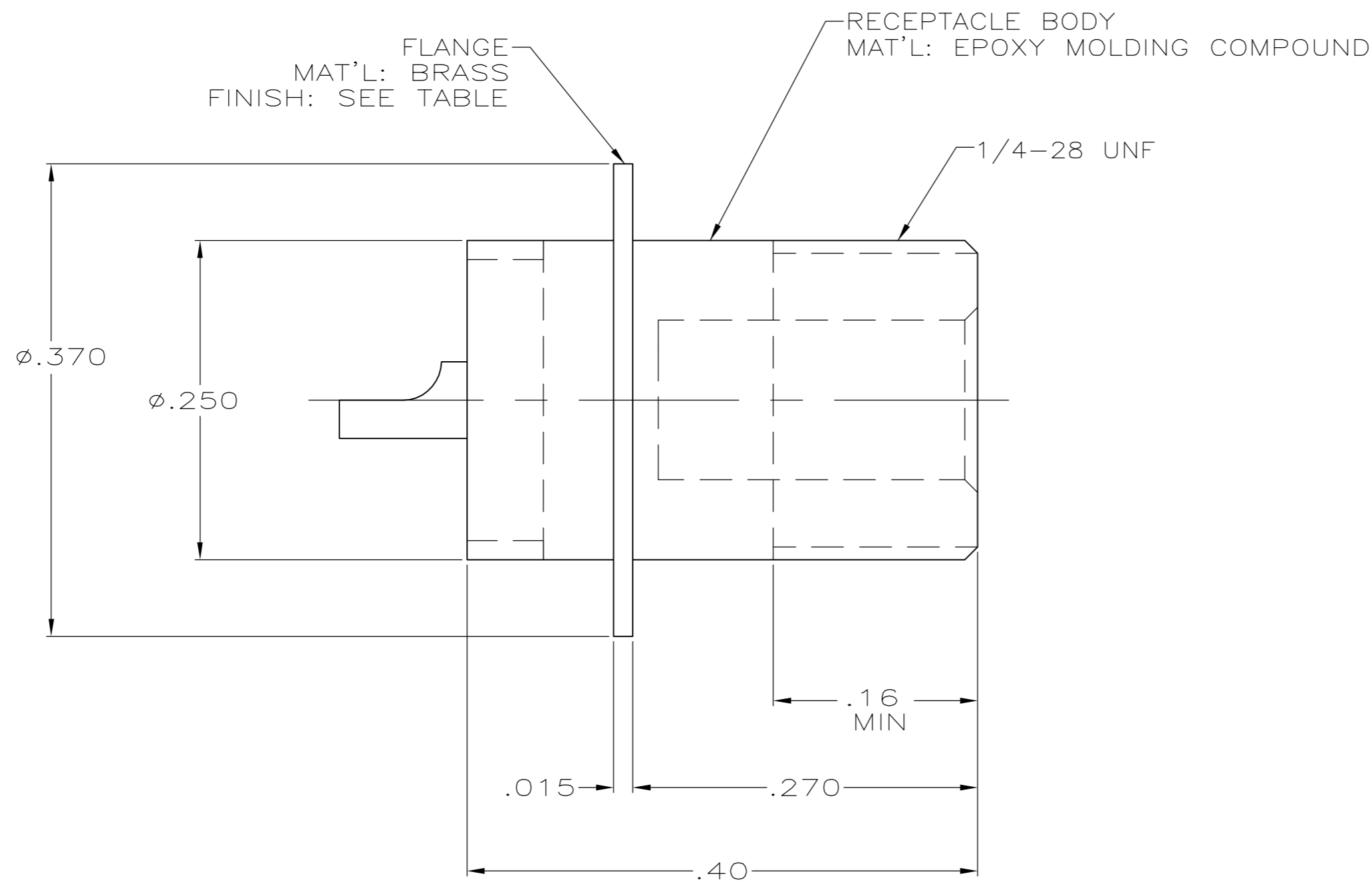

TIN	5-445159-1
TIN-LEAD	445159-1
FINISH	PART NO

THIS DRAWING IS A CONTROLLED DOCUMENT.		DWN	C.C.THOMAS	01-NOV-88	Tyco Electronics Corporation Harrisburg, Pa 17105-3608
DIMENSIONS: INCHES		CHK	M.GARDNER	05-NOV-88	
TOLERANCES UNLESS OTHERWISE SPECIFIED:		APVD	M.GARDNER	05-NOV-88	
0 PLC ± - 1 PLC ± - 2 PLC ± .02 3 PLC ± .010 4 PLC ± - ANGLES ± - FINISH SEE TABLE		PRODUCT SPEC	NAME		
MATERIAL SEE CALLOUTS		APPLICATION SPEC	RECEPTACLE METAL FLANGE LGH-1/4		RESTRICTED TO
		WEIGHT	-	SIZE	A2
		CUSTOMER DRAWING	CAGE CODE	00779	DRAWING NO
		SCALE	10:1	SHEET	1 OF 1
		REV	B		