

REVISIONS					
P	LTR	DESCRIPTION	DATE	OWN	APVD
D1		ECO-17-009556	03JUL2017	SW	RS

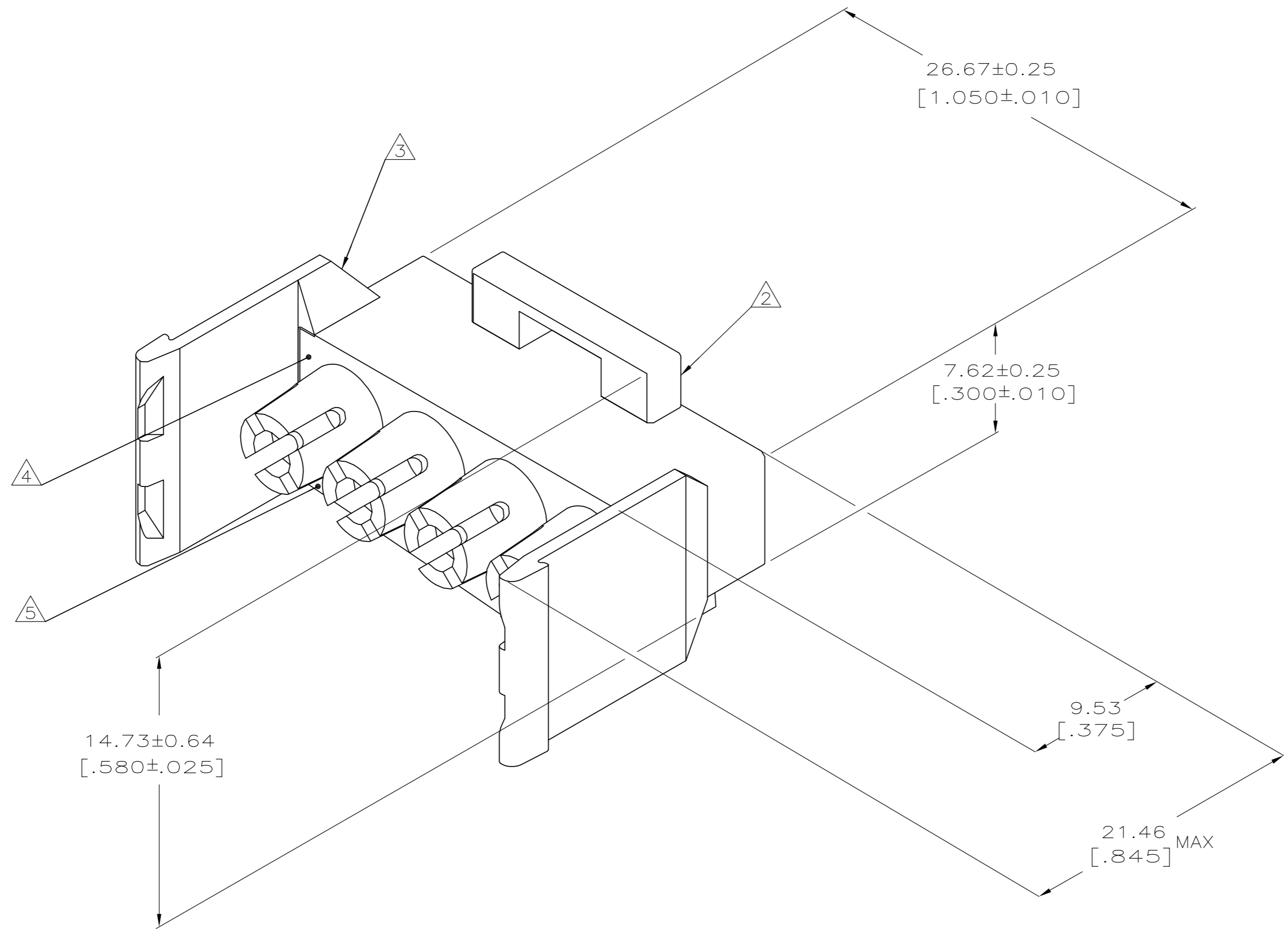

- MUST BE ASSEMBLED WITH CAP FRONT P/N 770049-1 BEFORE MATING. KIT P/N IS 770026-1.
- AMP LOGO LOCATED THIS SURFACE.
- UL AND CSA LOGOS LOCATED THIS SURFACE.
- CIRCUIT NO. 1 IDENTIFICATION BUTTON LOCATED APPROXIMATELY AS SHOWN FAR SIDE.
- LOCATION OF CIRCUIT NUMBERS MOVE BUT WILL REMAIN ADJACENT TO APPROPRIATE CAVITY (LOCATED FAR SIDE).
- DIMENSIONS SHOWN REPRESENT PRODUCT IN DRY, AS MOLDED, CONDITION. ADDITIONAL 2% GROWTH DUE TO SUBSEQUENT MOISTURE ABSORPTION MAY OCCUR AND SHOULD BE ACCOUNTED FOR.

770050-1
PART NUMBER

METRIC

THIS DRAWING IS A CONTROLLED DOCUMENT.		DWN K. SALMON	1-15-92		
		CHK R. SWING	1-15-92		
DIMENSIONS:		TOLERANCES UNLESS OTHERWISE SPECIFIED:		NAME	
INCHES				CAP REAR, 4 CIRCUIT, UNIVERSAL MATE-N-LOK	
0 PLC ± -		0 PLC ± -		PRODUCT SPEC	
1 PLC ± -		1 PLC ± -		APPLICATION SPEC	
2 PLC ± -		2 PLC ± -		SIZE	
3 PLC ± 0.13 [.005]		3 PLC ± 0.13 [.005]		CAGE CODE	
4 PLC ± -		4 PLC ± -		DRAWING NO	
ANGLES ± -		ANGLES ± -		RESTRICTED TO	
MATERIAL NYLON,UL94V-0,		FINISH		WEIGHT	
				0.000000	
				A1 00779 C=770050	
				CUSTOMER DRAWING	
				SCALE 5:1 SHEET 1 OF 1 REV D1	