

HLMP-3351, HLMP-3366, HLMP-3451, HLMP-3554, HLMP-3568

T-1³/₄ (5 mm) Low Profile LED Lamps



Description

The Broadcom® low profile T-1³/₄ package provides space savings and is excellent for backlighting applications.

Package Dimensions

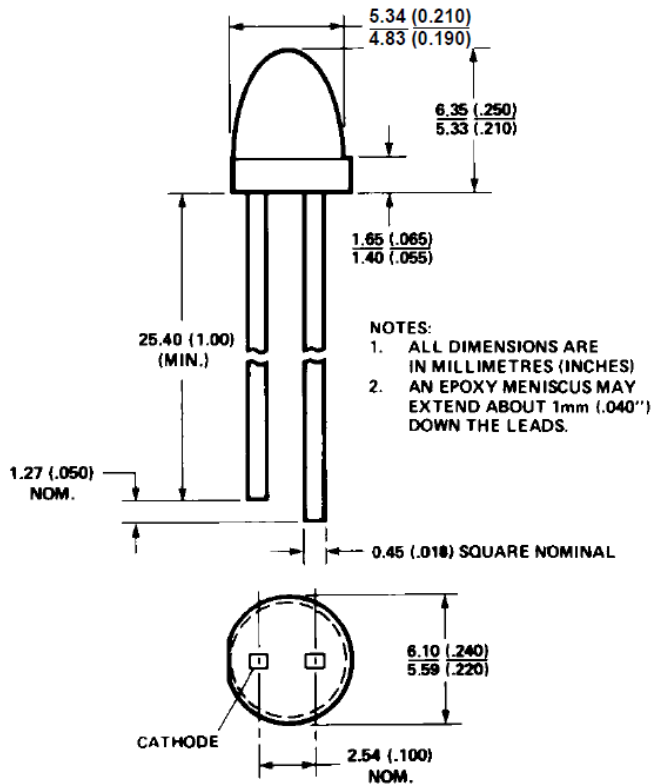

Features

- High intensity AlInGaP material
- Low profile: 5.8 mm (0.23 in.) nominal
- T-1³/₄ diameter package
- Diffused and non-diffused types
- General-purpose leads
- IC compatible/low current requirements
- Reliable and rugged

Device Selection Guide

Color	Package Description	Viewing Angle (degree) $2\theta_{1/2}^a$	Part Number HLMP-	Luminous Intensity I_v (mcd) at 10 mA	
				Min.	Max.
Red	T-1¼ Tinted, diffused	50	3351	5.4	—
			3351-D00xx	2.1	—
			3351-F00xx	5.4	—
	T-1¼ Tinted, non-diffused	45	3366	13.8	—
Yellow	T-1¼ Tinted, diffused	50	3451	3.6	—
			3451-D00xx	3.6	—
Green	T-1¼ Tinted, diffused	50	3554	6.7	—
			3554-E00xx	6.7	—
		T-1¼ Tinted, non-diffused	40	3568	10.6

a. $\theta_{1/2}$ is the off-axis angle at which the luminous intensity is half the axial luminous intensity.

Part Numbering System

H L M P -

x ₁	x ₂	x ₃	x ₄
----------------	----------------	----------------	----------------

 -

x ₅	x ₆	x ₇	x ₈	x ₉
----------------	----------------	----------------	----------------	----------------

Code	Description	Option	
x ₁	Package Type	3	T-1¼ (5 mm)
x ₂	Color	3	Red
		4	Yellow
		5	Green
x ₃ x ₄	Lens Option	5x	Tinted, diffused
		6x	Tinted, non-diffused
x ₅	Minimum Intensity Bin	See Intensity Bin Limits	
x ₆	Maximum Intensity Bin	0	Open bins (no maximum I_v bin limit)
x ₇	Color Bin Option	0	Full distribution
x ₈ x ₉	Packing Option	00	Bulk (loose forms packaging)
		01	Tape and reel, crimped leads
		02	Tape and reel, straight leads
		R1	Tape and reel, counterclockwise

Bin Information

Intensity Bin Limits

Color	Bin	Intensity Range (mcd)	
		Min.	Max.
Red	D	2.4	3.8
	E	3.8	6.1
	F	6.1	9.7
	G	9.7	15.5
	H	15.5	24.8
	I	24.8	39.6
	J	39.6	63.4
	K	63.4	101.5
	L	101.5	162.4
	M	162.4	234.6
	N	234.6	340.0
	O	340.0	540.0
	P	540.0	850.0
	Q	850.0	1200.0
	R	1200.0	1700.0
	S	1700.0	2400.0
	T	2400.0	3400.0
	U	3400.0	4900.0
	V	4900.0	7100.0
	W	7100.0	10200.0
X	10200.0	14800.0	
Y	14800.0	21400.0	
Z	21400.0	30900.0	

Color	Bin	Intensity Range (mcd)	
		Min.	Max.
Yellow	D	4.0	6.5
	E	6.5	10.3
	F	10.3	16.6
	G	16.6	26.5
	H	26.5	42.3
	I	42.3	67.7
	J	67.7	108.2
	K	108.2	173.2
	L	173.2	250.0
	M	250.0	360.0
	N	360.0	510.0
	O	510.0	800.0
	P	800.0	1250.0
	Q	1250.0	1800.0
	R	1800.0	2900.0
	S	2900.0	4700.0
	T	4700.0	7200.0
	U	7200.0	11700.0
	V	11700.0	18000.0
W	18000.0	27000.0	
Green	E	7.6	12.0
	F	12.0	19.1
	G	19.1	30.7
	H	30.7	49.1
	I	49.1	78.5
	J	78.5	125.7
	K	125.7	201.1
	L	201.1	289.0
	M	289.0	417.0
	N	417.0	680.0
	O	680.0	1100.0
	P	1100.0	1800.0
	Q	1800.0	2700.0
R	2700.0	4300.0	
S	4300.0	6800.0	
T	6800.0	10800.0	
U	10800.0	16000.0	
V	16000.0	25000.0	
W	25000.0	40000.0	

Maximum tolerance for each bin limit is ± 18%.

Color Categories

Color	Category Number	Lambda (nm)	
		Min.	Max.
Green	6	561.5	564.5
	5	564.5	567.5
	4	567.5	570.5
	3	570.5	573.5
	2	573.5	576.5
Yellow	1	582.0	584.5
	3	584.5	587.0
	2	587.0	589.5
	4	589.5	592.0
	5	592.0	593.0

Tolerance for each bin limit is ± 0.5 nm.

Packaging Option Matrix

Packaging Option Code	Definition
00	Bulk Packaging, minimum increment 500 pieces/bag
01	Tape and Reel, crimped leads, minimum increment 1300 pieces/reel
02	Tape and Reel, straight leads, minimum increment 1300 pieces/reel
R1	Tape and Reel, crimped leads, reeled counterclockwise, anode leaves first, minimum increment 1300 pieces/reel

NOTE: All categories are established for classification of products. Products may not be available in all categories. Contact your local Broadcom representative for further clarification/information.

Absolute Maximum Ratings at $T_A = 25^\circ\text{C}$

Parameter	Red	Yellow	Green	Units
Peak Forward Current	90	60	90	mA
Average Forward Current ^a	25	20	25	mA
DC Current ^b	30	20	30	mA
Power Dissipation ^c	135	85	135	mW
Reverse Voltage ($I_R = 100 \mu\text{A}$)	5	5	5	V
Operating Temperature Range	-40 to +100	-40 to +100	-20 to +100	$^\circ\text{C}$
Storage Temperature Range	-40 to +100	-40 to +100	-40 to +100	$^\circ\text{C}$
Wave Soldering Temperature (1.59 mm [0.063 in.] from Body)	250 $^\circ\text{C}$ for 3 seconds			

- a. See Figure 4 (Red), Figure 8 (Yellow), or Figure 12 (Green) to establish pulsed operating conditions.
- b. For Green Series, derate linearly from 50 $^\circ\text{C}$ at 0.5 mA/ $^\circ\text{C}$. For Red and Yellow Series, derate linearly from 50 $^\circ\text{C}$ at 0.2 mA/ $^\circ\text{C}$.
- c. For Green Series, derate power linearly from 25 $^\circ\text{C}$ at 1.8 mW/ $^\circ\text{C}$. For Red and Yellow Series, derate power linearly from 50 $^\circ\text{C}$ at 1.6 mW/ $^\circ\text{C}$.

Figure 1: Relative Intensity vs. Wavelength

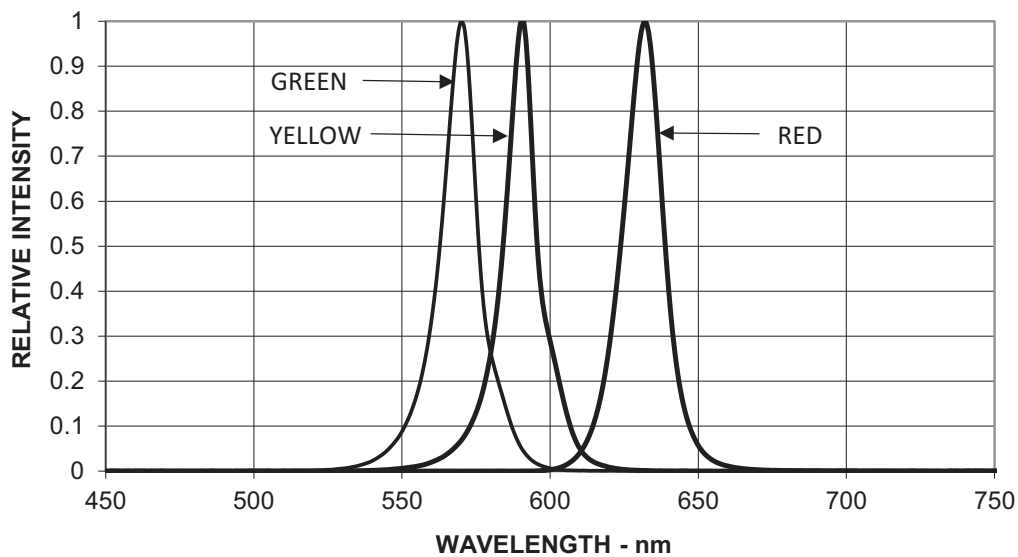

Red HLMP-335x/-336x Series

Electrical/Optical Specifications at $T_A = 25^\circ\text{C}$

Symbol	Description	Device HLMP-	Min.	Typ.	Max.	Units	Test Conditions
$2\theta_{1/2}$	Including Angle Between Half Luminous Intensity Points	3351	—	50	—	Deg.	Note ^a
		3366	—	45	—		
λ_{PEAK}	Peak Wavelength		—	632	—	nm	Measurement at Peak
λ_{d}	Dominant Wavelength		—	626	—	nm	Note ^b
$\Delta\lambda_{1/2}$	Spectral Line Halfwidth		—	14	—	nm	
τ_s	Speed of Response		—	90	—	ns	
C	Capacitance		—	11	—	pF	$V_F = 0$; $f = 1 \text{ MHz}$
$R\theta_{\text{J-PIN}}$	Thermal Resistance		—	260	—	$^\circ\text{C/W}$	Junction to Cathode Lead
V_F	Forward Voltage		—	1.9	2.4	V	$I_F = 10 \text{ mA}$
V_R	Reverse Breakdown Voltage		5.0	—	—	V	$I_R = 100 \mu\text{A}$
η_V	Luminous Efficacy		—	180	—	lm/W	Note ^c

- a. $\theta_{1/2}$ is the off-axis angle at which the luminous intensity is half the axial luminous intensity.
- b. Dominant wavelength, λ_{d} , is derived from the CIE chromaticity diagram and represents the single wavelength that defines the color of the device.
- c. Radiant Intensity, I_e , in watts/steradian may be found from the equation $I_e = I_v / \eta_V$, where I_v is the luminous intensity in candelas and h_v is the luminous efficacy in lumens/watt.

Figure 2: Forward Current vs. Forward Voltage

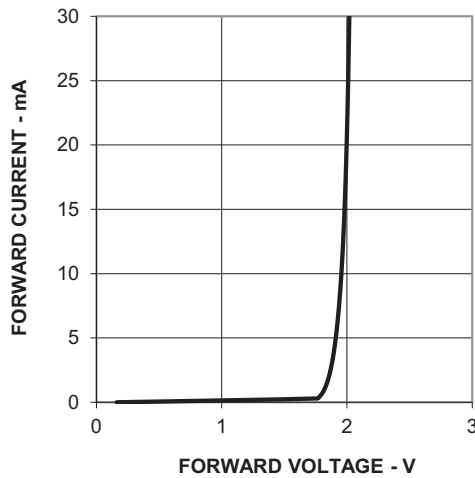

Figure 3: Relative Luminous Intensity vs. Forward Current

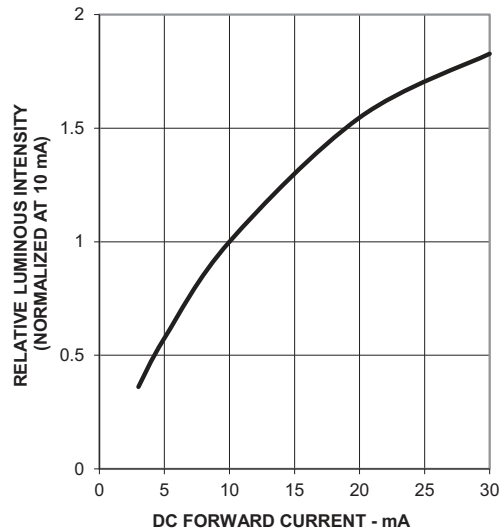

Figure 4: Maximum Tolerable Peak Current vs. Pulse Duration (I_{DC} MAX as per MAX ratings)

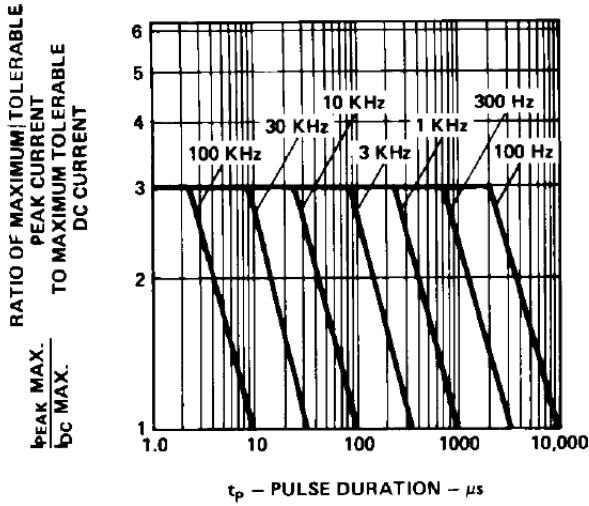
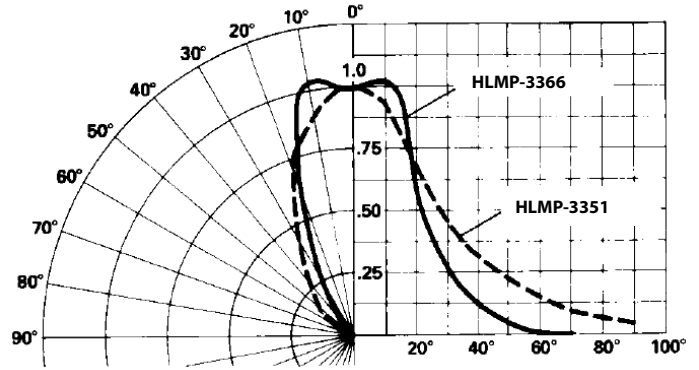

Figure 5: Relative Luminous Intensity vs. Angular Displacement



Yellow HLMP-345x Series

Electrical/Optical Specifications at T_A = 25°C

Symbol	Description	Device HLMP-	Min.	Typ.	Max.	Units	Test Conditions
2θ _{1/2}	Including Angle Between Half Luminous Intensity Points	3451	—	50	—	Deg.	Note ^a
λ _{PEAK}	Peak Wavelength		—	590	—	nm	Measurement at Peak
λ _d	Dominant Wavelength		—	589	—	nm	Note ^b
Δλ _{1/2}	Spectral Line Halfwidth		—	12	—	nm	
τ _s	Speed of Response		—	90	—	ns	
C	Capacitance		—	15	—	pF	V _F = 0; f = 1 MHz
Rθ _{J-PIN}	Thermal Resistance		—	260	—	°C/W	Junction to Cathode Lead
V _F	Forward Voltage		—	1.9	2.4	V	I _F = 10 mA
V _R	Reverse Breakdown Voltage		5.0	—	—	V	I _R = 100 μA
η _V	Luminous Efficacy		—	500	—	lm/W	Note ^c

- a. θ_{1/2} is the off-axis angle at which the luminous intensity is half the axial luminous intensity.
- b. Dominant wavelength, λ_d, is derived from the CIE chromaticity diagram and represents the single wavelength that defines the color of the device.
- c. Radiant Intensity, I_e, in watts/steradian may be found from the equation I_e = I_v / η_v, where I_v is the luminous intensity in candelas and η_v is the luminous efficacy in lumens/watt.

Figure 6: Forward Current vs. Forward Voltage

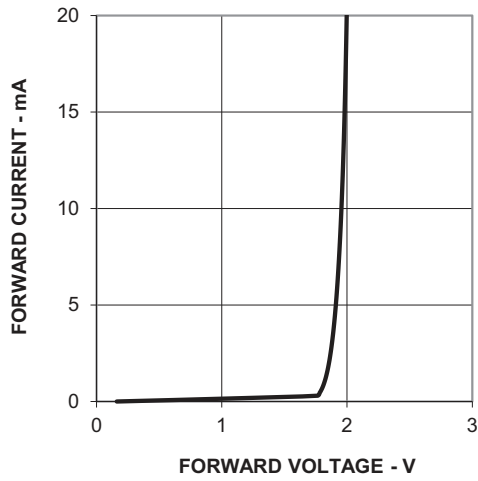

Figure 7: Relative Luminous Intensity vs. Forward Current

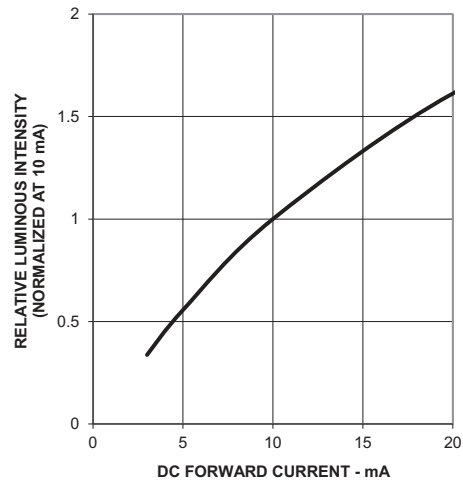

Figure 8: Maximum Tolerable Peak Current vs. Pulse Duration ($I_{DC\ MAX}$ as per MAX ratings)

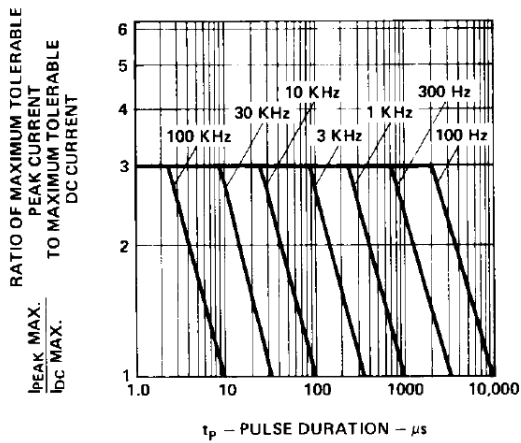
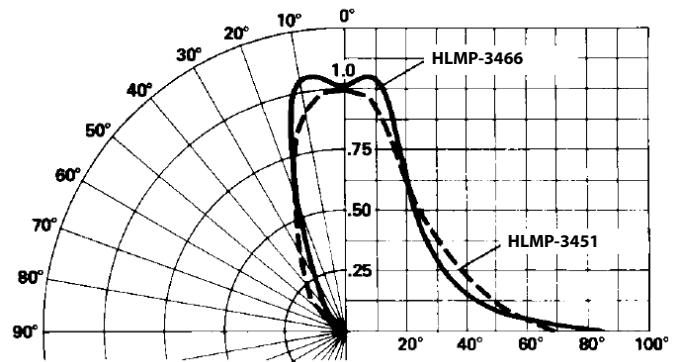

Figure 9: Relative Luminous Intensity vs. Angular Displacement



Green HLMP-355x/-356x Series

Electrical/Optical Specifications at T_A = 25°C

Symbol	Description	Device HLMP-	Min.	Typ.	Max.	Units	Test Conditions
2θ _{1/2}	Including Angle Between Half Luminous Intensity Points	3554	—	50	—	Deg.	Note ^a
		3568		40			
λ _{PEAK}	Peak Wavelength		—	570	—	nm	Measurement at Peak
λ _d	Dominant Wavelength		—	569	—	nm	Note ^b
Δλ _{1/2}	Spectral Line Halfwidth		—	13	—	nm	
τ _s	Speed of Response		—	500	—	ns	
C	Capacitance		—	18	—	pF	V _F = 0; f = 1 MHz
Rθ _{J-PIN}	Thermal Resistance		—	260	—	°C/W	Junction to Cathode Lead
V _F	Forward Voltage		—	2.0	2.7	V	I _F = 10 mA
V _R	Reverse Breakdown Voltage		5.0	—	—	V	I _R = 100 μA
η _V	Luminous Efficacy		—	640	—	lm/W	Note ^c

- a. θ_{1/2} is the off-axis angle at which the luminous intensity is half the axial luminous intensity.
- b. Dominant wavelength, λ_d, is derived from the CIE chromaticity diagram and represents the single wavelength that defines the color of the device.
- c. Radiant Intensity, I_e, in watts/steradian may be found from the equation I_e = I_v / η_v, where I_v is the luminous intensity in candelas and η_v is the luminous efficacy in lumens/watt.

Figure 10: Forward Current vs. Forward Voltage

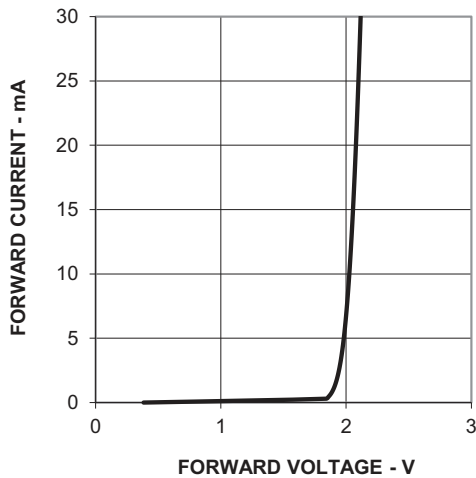

Figure 11: Relative Luminous Intensity vs. Forward Current

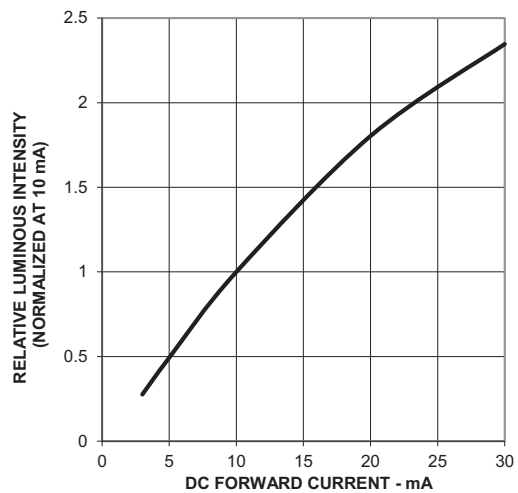

Figure 12: Maximum Tolerable Peak Current vs. Pulse Duration (I_{DC} MAX as per MAX ratings)

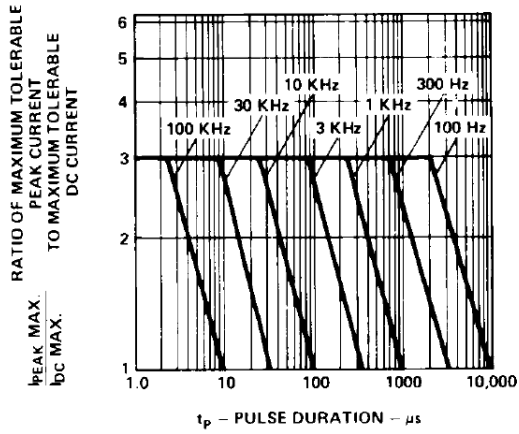
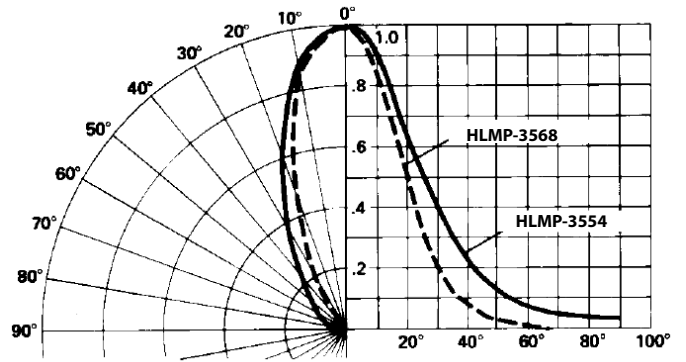

Figure 13: Relative Luminous Intensity vs. Angular Displacement



Precautions

Lead Forming

- The leads of an LED lamp may be preformed or cut to length prior to insertion and soldering on PC board.
- For better control, use the proper tool to precisely form and cut the leads to applicable length rather than doing it manually.
- If manual lead cutting is necessary, cut the leads after the soldering process. The solder connection forms a mechanical ground that prevents mechanical stress due to lead cutting from traveling into LED package. Use this method for the hand soldering operation, because the excess lead length also acts as small heat sink.

Soldering and Handling

- Take care during the PCB assembly and soldering process to prevent damage to the LED component.
- LED component may be effectively hand soldered to PCB. However, do this under unavoidable circumstances, such as rework. The closest manual soldering distance of the soldering heat source (soldering iron’s tip) to the body is 1.59 mm. Soldering the LED using soldering iron tip closer than 1.59 mm might damage the LED.

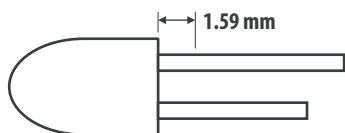

- Apply ESD precautions on the soldering station and personnel to prevent ESD damage to the LED component that is ESD sensitive. Refer to Broadcom application note AN 1142 for details. The soldering iron used must have a grounded tip to ensure electrostatic charge is properly grounded.
- Recommended soldering condition.

Wave Soldering ^{a, b}	Manual Solder Dipping	
Pre-heat Temperature	105°C max.	—
Pre-heat Time	60s max.	—
Peak Temperature	250°C max.	260°C max.
Dwell Time	3s max.	5s max.

a. The preceding conditions refer to measurement with a thermocouple mounted at the bottom of the PCB.

b. Use only bottom pre-heaters to reduce thermal stress experienced by LED.

- Set and maintain wave soldering parameters according to the recommended temperature and dwell time. Perform daily checks on the soldering profile to ensure that it always conforms to the recommended soldering conditions.

NOTE:

1. PCBs with different size and design (component density) will have a different heat mass (heat capacity). This might cause a change in temperature experienced by the board if the same wave soldering setting is used. Therefore, recalibrate the soldering profile again before loading a new type of PCB.
 2. Take extra precautions during wave soldering to ensure that the maximum wave temperature does not exceed 250°C and the solder contact time does not exceed 3s. Over-stressing the LED during the soldering process might cause premature failure to the LED due to delamination.
- Loosely fit any alignment fixture that is being applied during wave soldering and do not apply weight or force on the LED. Use nonmetal material because it absorbs less heat during the wave soldering process.
 - At elevated temperature, LED is more susceptible to mechanical stress. Therefore, allow the PCB to cool down to room temperature prior to handling, which includes removal of alignment fixture or pallet.
 - If PCB board contains both through-hole (TH) LED and other surface-mount components, solder surface-mount components on the top side of the PCB. If the surface mount must be on the bottom side, solder these components using reflow soldering prior to the insertion of the TH LED.
 - The recommended PC board plated through holes (PTH) size for LED component leads follows.

	LED Component Lead Size	Diagonal	Plated Through-Hole Diameter
Lead size (typ.)	0.45 × 0.45 mm (0.018 × 0.018 in.)	0.636 mm (0.025 in.)	0.98 to 1.08 mm (0.039 to 0.043 in.)
Dambar shear-off area (max.)	0.65 mm (0.026 in.)	0.919 mm (0.036 in.)	
Lead size (typ.)	0.50 × 0.50 mm (0.020 × 0.020 in.)	0.707 mm (0.028 in.)	1.05 to 1.15 mm (0.041 to 0.045 in.)
Dambar shear-off area (max.)	0.70 mm (0.028 in.)	0.99 mm (0.039 in.)	

NOTE: Refer to application note AN1027 for more information on soldering LED components.

- Over-sizing the PTH can lead to twisted LED after clinching. On the other hand under sizing the PTH can cause difficulty inserting the TH LED.

Figure 14: Example of Wave Soldering Temperature Profile for TH LED

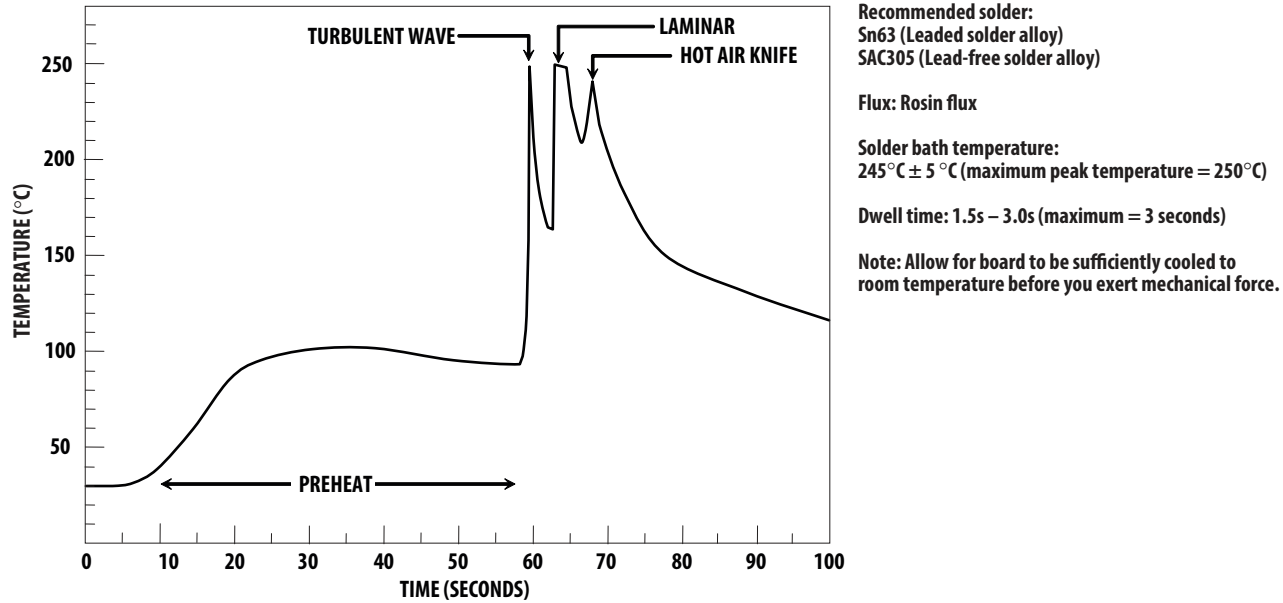

Broadcom, the pulse logo, Connecting everything, Avago Technologies, Avago, and the A logo are among the trademarks of Broadcom and/or its affiliates in the United States, certain other countries, and/or the EU.

Copyright © 2008–2021 Broadcom. All Rights Reserved.

The term “Broadcom” refers to Broadcom Inc. and/or its subsidiaries. For more information, please visit www.broadcom.com.

Broadcom reserves the right to make changes without further notice to any products or data herein to improve reliability, function, or design. Information furnished by Broadcom is believed to be accurate and reliable. However, Broadcom does not assume any liability arising out of the application or use of this information, nor the application or use of any product or circuit described herein, neither does it convey any license under its patent rights nor the rights of others.

