

APPROVAL SHEET



WLSSA38G Series
Shielded SMD Power Inductors

*Contents in this sheet are subject to change without prior notice.

Features

1. Shielded power inductor.
2. Wide inductance range.

Applications

1. Inductor in DC/DC converter.
2. Use in STB、PDA、Notebook.

Shape and Dimension

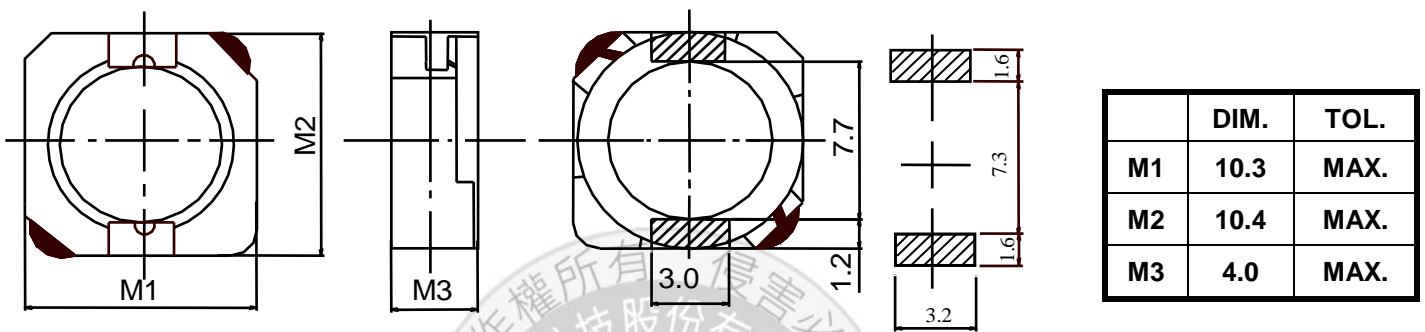

Unit : mm

Ordering Information

WL	SS	A38G	Z0	N	1R5	L	B
Product Code WL: Inductor	Series Shielded SMD Power Inductors	Dimensions 10.3 * 10.4 mm	Series extension Z0:STD	Tolerance N: ±30%	Value 1R5 = 1.5uH 100 = 10.0uH 101 =100uH	Packing Code L=13" Reeled (Embossed tape)	B:STD

Electrical Characteristics

WLSSA38G Series	Marking	L (uH)	Inductance Tolerance	Test Freq (KHz)	DCR (mΩ) MAX.	I sat (A)	Rated Current (A)
WLSSA38GZ0N1R5LB	1R5	1.5	±30%	100	8.1	10.0	6.50
WLSSA38GZ0N2R5LB	2R5	2.5	±30%	100	10.5	7.50	6.10
WLSSA38GZ0N3R8LB	3R8	3.8	±30%	100	13.0	6.00	5.50
WLSSA38GZ0N5R2LB	5R2	5.2	±30%	100	22	5.50	5.40
WLSSA38GZ0N6R8LB	6R8	6.8	±30%	100	25	4.80	4.50
WLSSA38GZ0N7R0LB	7R0	7.0	±30%	100	27	4.80	4.50
WLSSA38GZ0N100LB	100	10	±30%	100	35	4.40	3.80
WLSSA38GZ0N150LB	150	15	±30%	100	50	3.60	3.10
WLSSA38GZ0N220LB	220	22	±30%	100	73	2.90	2.50
WLSSA38GZ0N330LB	330	33	±30%	100	93	2.30	2.20
WLSSA38GZ0N470LB	470	47	±30%	100	128	2.10	1.90
WLSSA38GZ0N680LB	680	68	±30%	100	213	1.50	1.42
WLSSA38GZ0N101LB	101	100	±30%	100	304	1.35	1.25
WLSSA38GZ0N151LB	151	150	±30%	100	506	1.15	0.85
WLSSA38GZ0N221LB	221	220	±30%	100	756	0.92	0.70
WLSSA38GZ0N331LB	331	330	±30%	100	1090	0.70	0.52

a. Tolerance : N : ±30%

b. Operating Temp : -25°C to +105°C.

c. Inductance measured using the HP4284A LCR meter, CHROMA1320 & 3302 & 16502.

d. DCR measured using the 502BC milli-ohm meter.

e. Inductance drops no more than 35% of initial value at Isat , temperature rises $\Delta t < 30^{\circ}\text{C}$

at rated current.

f. MSL : LEVEL 1

TYPICAL RoHS REFLOW PROFILE

Typical RoHS Reflow Profile

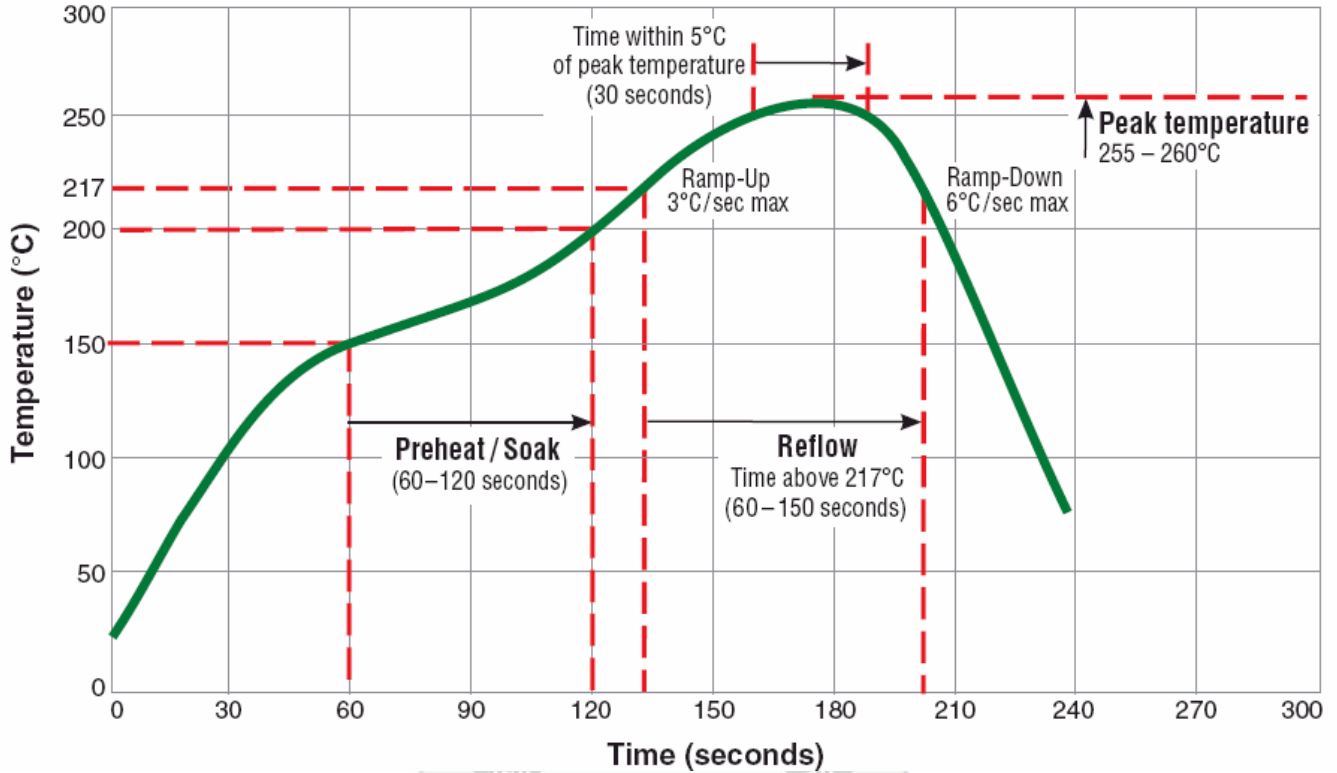

RELIABILITY PERFORMANCE

Reliability Experiment For Electrical

Test Item	Test Condition	Standard Source
Humidity Test	+40°C ± 2°C, humidity of 90% ± 5% (total 96 hours).	MIL-STD-202G Method 103B Test Condition B
High Temperature Test	1. Temperature: +125°C ± 2°C 2. Test time: 48 ± 2hrs	IEC 68-2 Test Condition B
Low Temperature Test	1. Temperature: -40°C ± 2°C 2. Test time: 48 ± 2hrs	IEC 68-2 Test Condition A
Thermal Shock	+125°C ± 5°C (30 minutes) ~ -40 ± 5°C (30 minutes), temperature switch time: 5 minutes (total 50 cycles).	MIL-STD-202G Method 107G Test Condition B-2
Life Test	+70°C ± 5°C (250Hours)	MIL-STD-202G Method 108A Test Condition B

Reliability Experiment For Physical

Test Item	Test Condition	Standard Source
Vibration Test	10-55-10HZ, amplitude: 1.5mm, direction: X, Y, Z axes, each axis 2 hours (total 6 hours).	MIL-STD-202G Method 201A
Solder Heat Resistance Test	IR/convection reflow: Peak Temp 250 ± 5°C for 5Sec in air, Through 2 Cycle. Temperature Ramp: +1~4°C/sec; Above 183°C, must keep 90 s - 120 s	MIL-STD-202G Method 210F Test Condition (Reflow)
Solder Ability Test	Soak in 245 °C solder pot of 3Sec, PAD must have 95% above coverage.	J-STD-003B

Tape & Reel Packaging Dimensions:

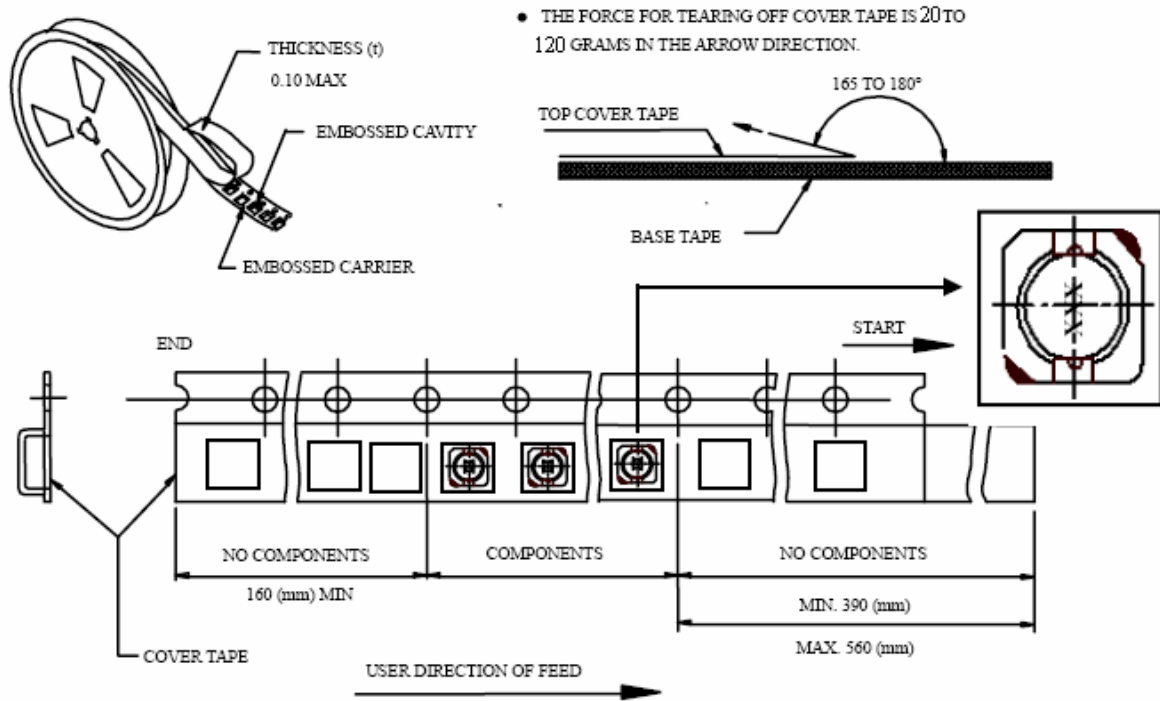

■ CARRIER TAPE REELS (mm)

MATERIAL: PLASTIC

■ DIMENSIONS OF CARRIER TAPE (mm)

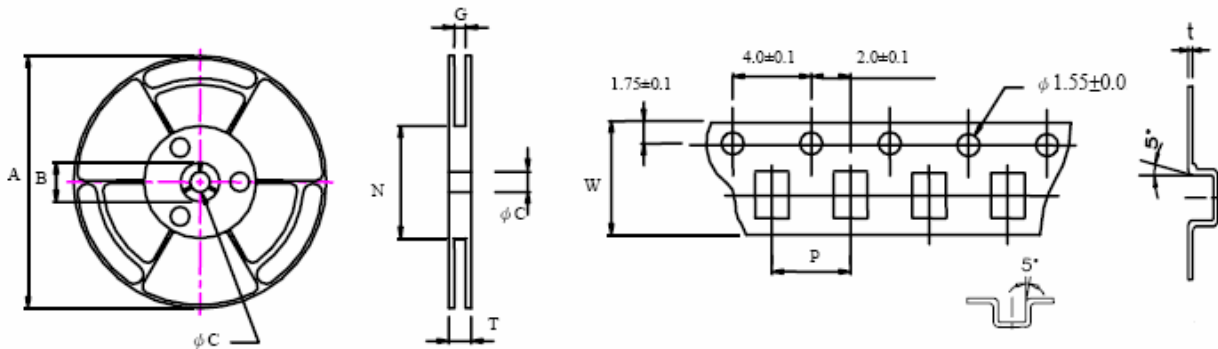

Unit : mm

	A	B	C	G	N	P	T	W	t
DIM.	340	20.2	13.0	24.4	100	16.0	30.5	24	0.35
TOL.	MAX	MIN	±0.5	±2.0	MIN	±0.1	MAX	±0.3	±0.05

Quantity per reel : 1,000 pcs