

THIS DRAWING IS UNPUBLISHED. RELEASED FOR PUBLICATION  
 © COPYRIGHT - TE Connectivity ALL RIGHTS RESERVED.

REVISIONS					
P	LTR	DESCRIPTION	DATE	DWN	APVD
E		REV PER ECO 18-000325	2-6-18	CT	RL

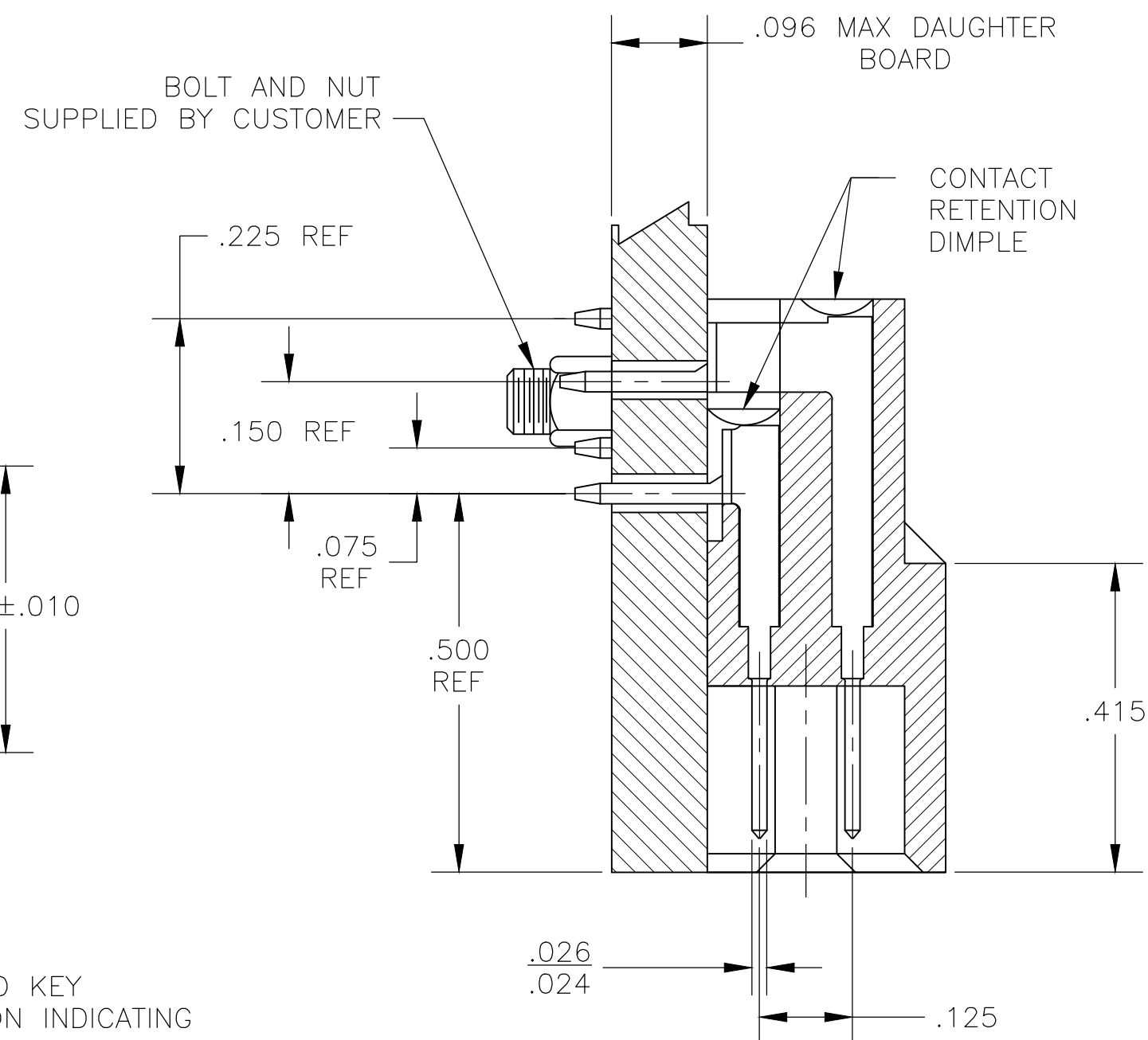
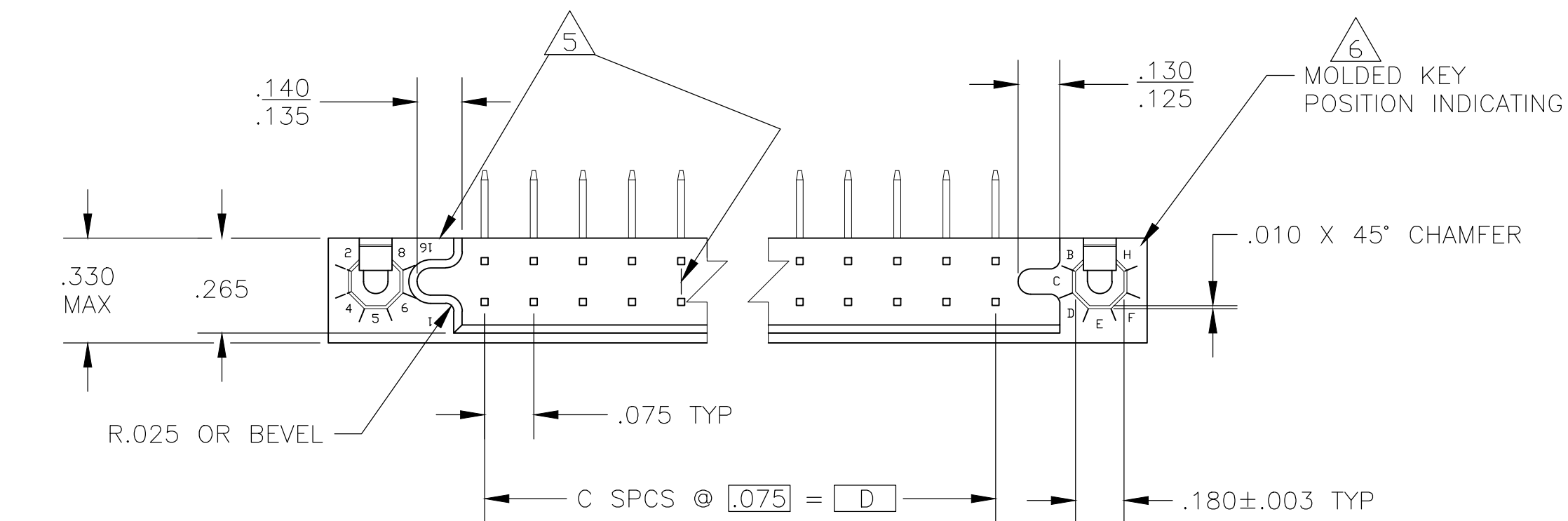
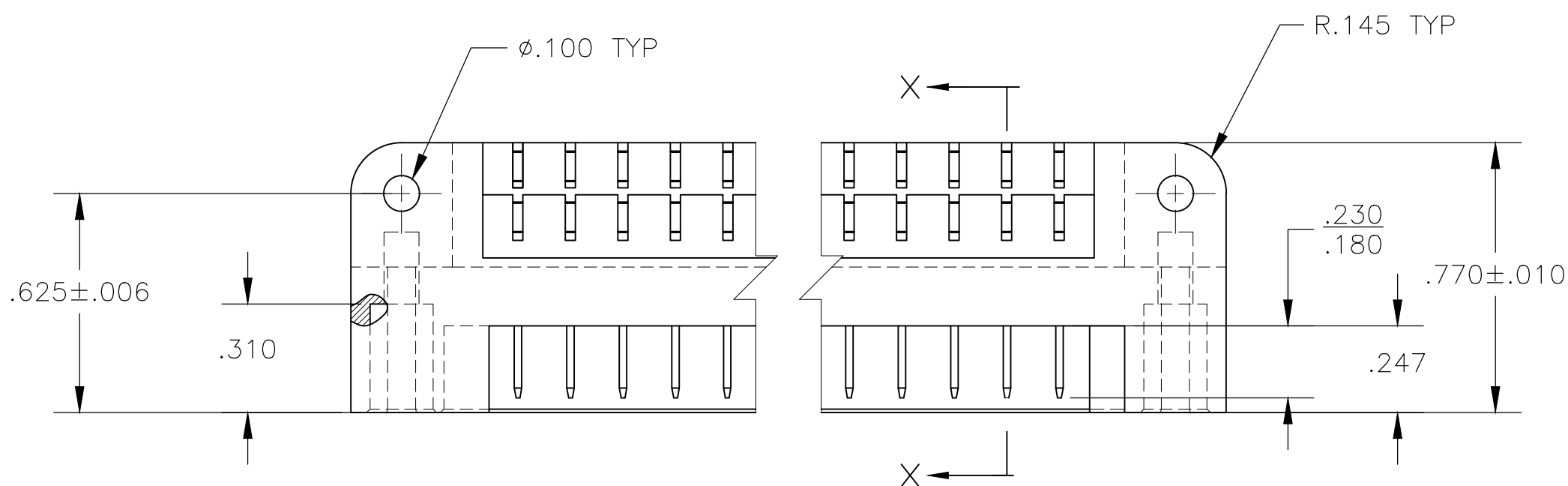
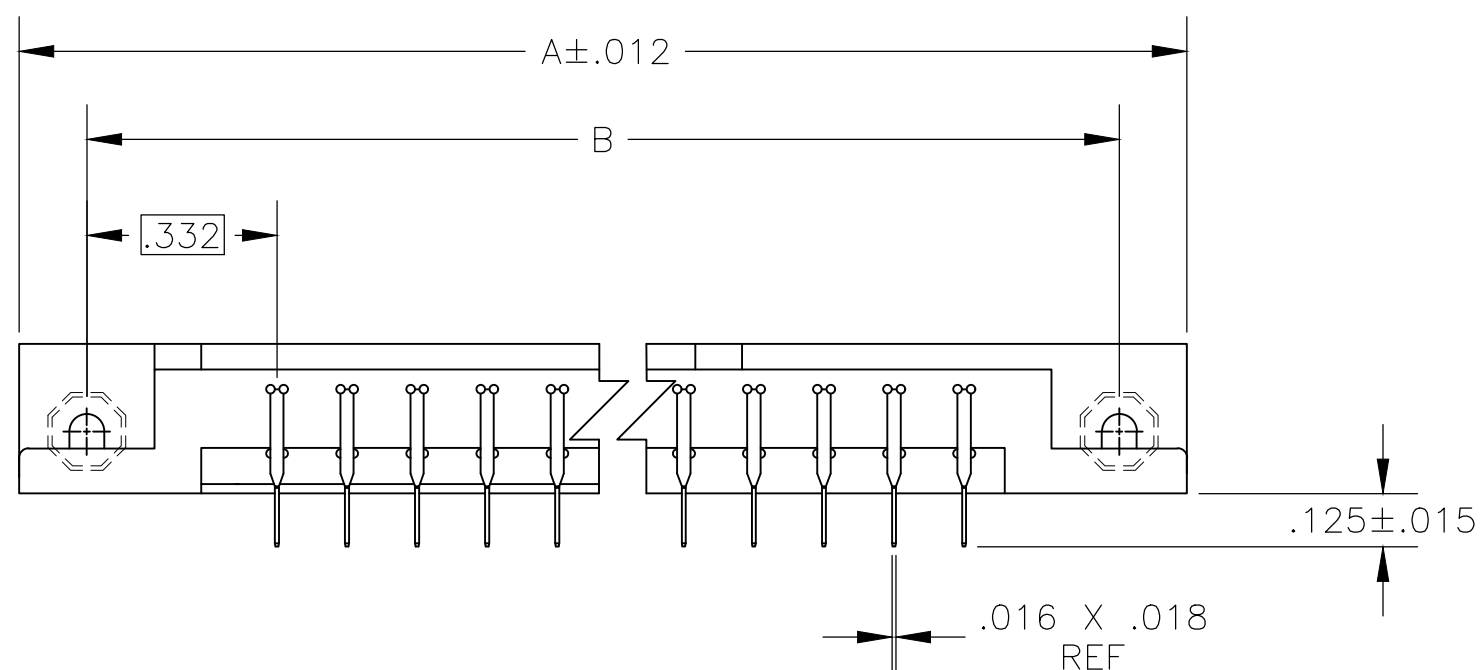

SECTION X-X  
SCALE 10:1

THIS DRAWING IS A CONTROLLED DOCUMENT.		DWN B. LATTUCA 18JAN2006																										
DIMENSIONS: INCHES		CHK C. C. THOMAS 18JAN2006																										
TOLERANCES UNLESS OTHERWISE SPECIFIED:		APVD C. C. THOMAS 18JAN2006	NAME PIN ASSEMBLY, RIGHT ANGLE 751 SERIES, BOX CONNECTOR																									
<table border="1"> <tr><td>0</td><td>PLC</td><td>±</td><td>-</td></tr> <tr><td>1</td><td>PLC</td><td>±</td><td>-</td></tr> <tr><td>2</td><td>PLC</td><td>±</td><td>-</td></tr> <tr><td>3</td><td>PLC</td><td>±</td><td>-</td></tr> <tr><td>4</td><td>PLC</td><td>±</td><td>-</td></tr> <tr><td></td><td>ANGLES</td><td>±</td><td>-</td></tr> </table>		0	PLC	±	-	1	PLC	±	-	2	PLC	±	-	3	PLC	±	-	4	PLC	±	-		ANGLES	±	-	PRODUCT SPEC APPLICATION SPEC	SIZE A2	CAGE CODE 00779
0	PLC	±	-																									
1	PLC	±	-																									
2	PLC	±	-																									
3	PLC	±	-																									
4	PLC	±	-																									
	ANGLES	±	-																									
MATERIAL 		FINISH 	WEIGHT 0	DRAWING NO C=531720																								
CUSTOMER DRAWING			SCALE NTS	SHEET 1 OF 2																								
			RESTRICTED TO -	REV E																								

REVISIONS					
P	LTR	DESCRIPTION	DATE	DWN	APVD
-	-	SEE SHEET 1	-	-	-

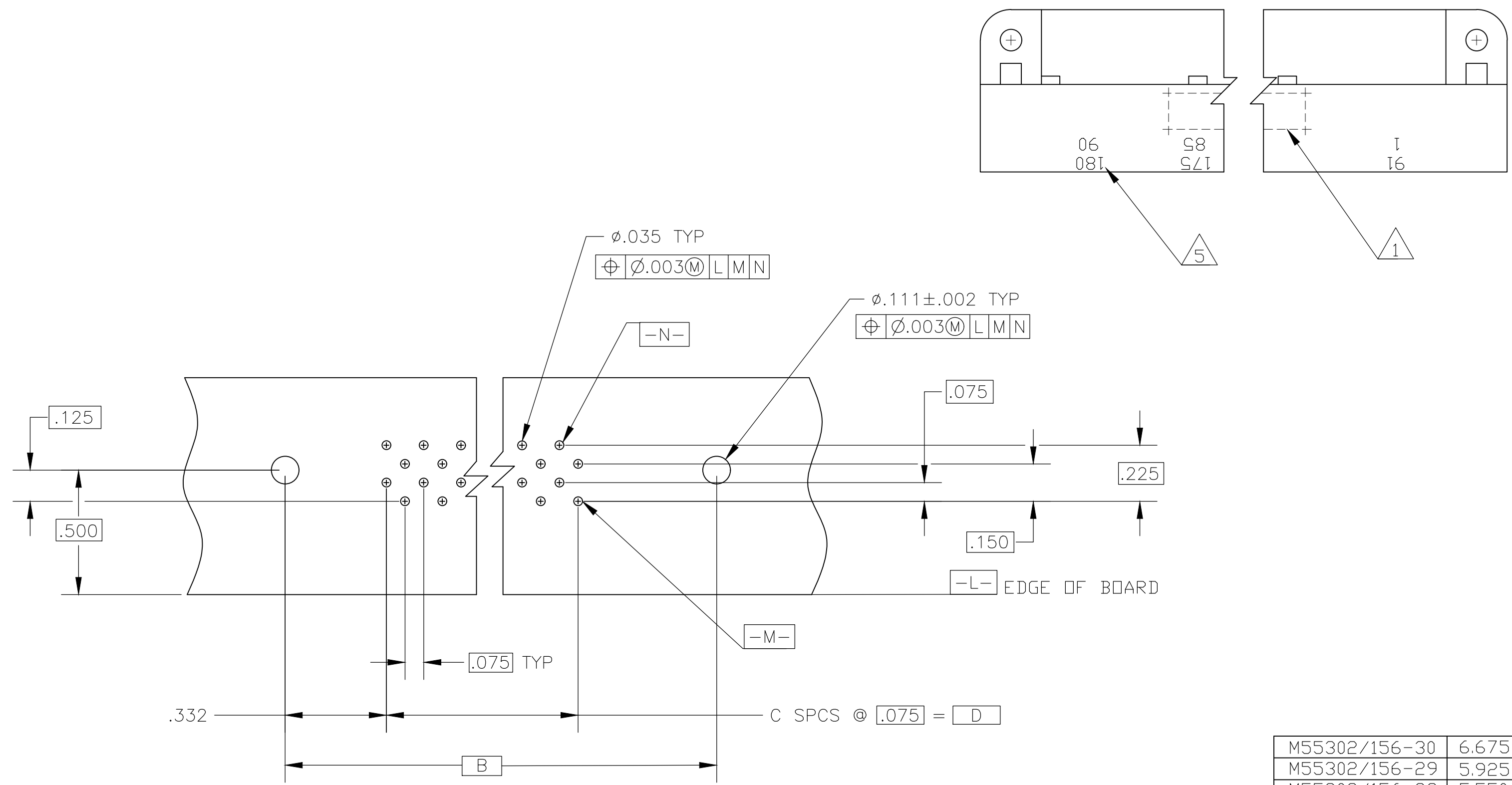

RECOMMENDED P.C. BOARD LAYOUT  
(CONNECTOR SIDE)

M55302/156-30	6.675	89	7.340	7.630	180	1-531720-5
M55302/156-29	5.925	79	6.590	6.880	160	1-531720-4
M55302/156-28	5.550	74	6.215	6.505	150	1-531720-3
M55302/156-27	4.425	59	5.090	5.380	120	1-531720-2
M55302/156-26	4.050	54	4.715	5.005	110	1-531720-1
M55302/156-25	3.675	49	4.340	4.630	100	1-531720-0
M55302/156-24	3.300	44	3.965	4.255	90	531720-9
M55302/156-23	2.925	39	3.590	3.880	80	531720-8
M55302/156-22	2.550	34	3.215	3.505	70	531720-7
M55302/156-21	2.175	29	2.840	3.130	60	531720-6
M55302/156-20	1.800	24	2.465	2.755	50	531720-5
M55302/156-19	1.425	19	2.090	2.380	40	531720-4
M55302/156-18	1.050	14	1.715	2.005	30	531720-3
M55302/156-17	.675	9	1.340	1.630	20	531720-2
M55302/156-16	.300	4	.965	1.255	10	531720-1
MILITARY PART NUMBER	D	C	B	A	NO OF POS	PART NO

- ① AMP, PART NUMBER, MILITARY PART NO, DATE CODE, & 00779 MARKED THIS AREA.
- ② HOUSING MATERIAL: GLASS FILLED POLYESTER. COLOR: BLUE.
- ③ CONTACT MATERIAL: BRASS  
FINISH: .000050 GOLD OVER .000050 NICKEL IN CONTACT AREA, TIN-LEAD PLATE OVER NICKEL ON SOLDER TAILS.
- MIL-C-55302 GROUP A INSPECTION REQUIRED
- ⑤ NUMBERS & LINES INDICATING EVERY 5 CAVITIES MARKED ON MATING FACE. NUMBERS INDICATING EVERY 5 CAVITIES MARKED ON SIDE.
- ⑥ KEY POSITION IDENTIFICATION MOLDED ON SURFACE SHOWN.

THIS DRAWING IS A CONTROLLED DOCUMENT.

DIMENSIONS: INCHES	TOLERANCES UNLESS OTHERWISE SPECIFIED:	DWN B. LATTUCA 18JAN2006	
	0 PLC ± -	CHK C. C. THOMAS 18JAN2006	
	1 PLC ± -	APVD C. C. THOMAS 18JAN2006	
	2 PLC ± -	PRODUCT SPEC	
MATERIAL	FINISH	3 PLC ± -	NAME
		4 PLC ± -	PIN ASSEMBLY, RIGHT ANGLE
		ANGLES ± -	751 SERIES, BOX CONNECTOR
			SIZE CAGE CODE DRAWING NO RESTRICTED TO
			A2 00779 C-531720 -
			CUSTOMER DRAWING SCALE NTS SHEET 2 OF 2 REV E