



## Mounting aid

### MH 01-M18

- Suitable for M18 sensors
- Simple and fast mounting

Mounting brackets for sensors

## Dimensions

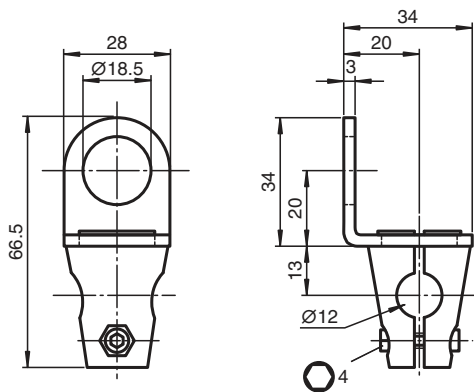

## Technical Data

### General specifications

Inside diameter 18 mm

### Mechanical specifications

Material Clamping cylinder: Diecast zinc  
Support bracket: Steel

**Mounting**

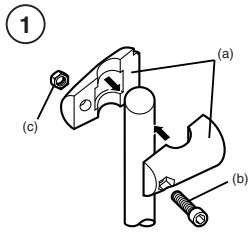

Fasten the two parts of the mounting clamp (a) loosely by means of the screw (b) and the nut (c) supplied.

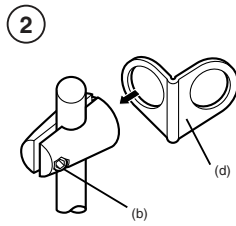

Attach the mounting bracket (d) and then tighten the screw (b) in such a way that the bracket can still be turned.

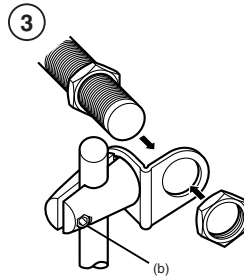

Tighten the screw fully after the sensor has been mounted and aligned.