

REV	DATE	DESCRIPTION	BY	APPD
P1	18JAN2018	REVISED PER ECR-18-004355	BDA	SG
R	18OCT2018	REVISED PER ECR-19-015071	BDA	SW

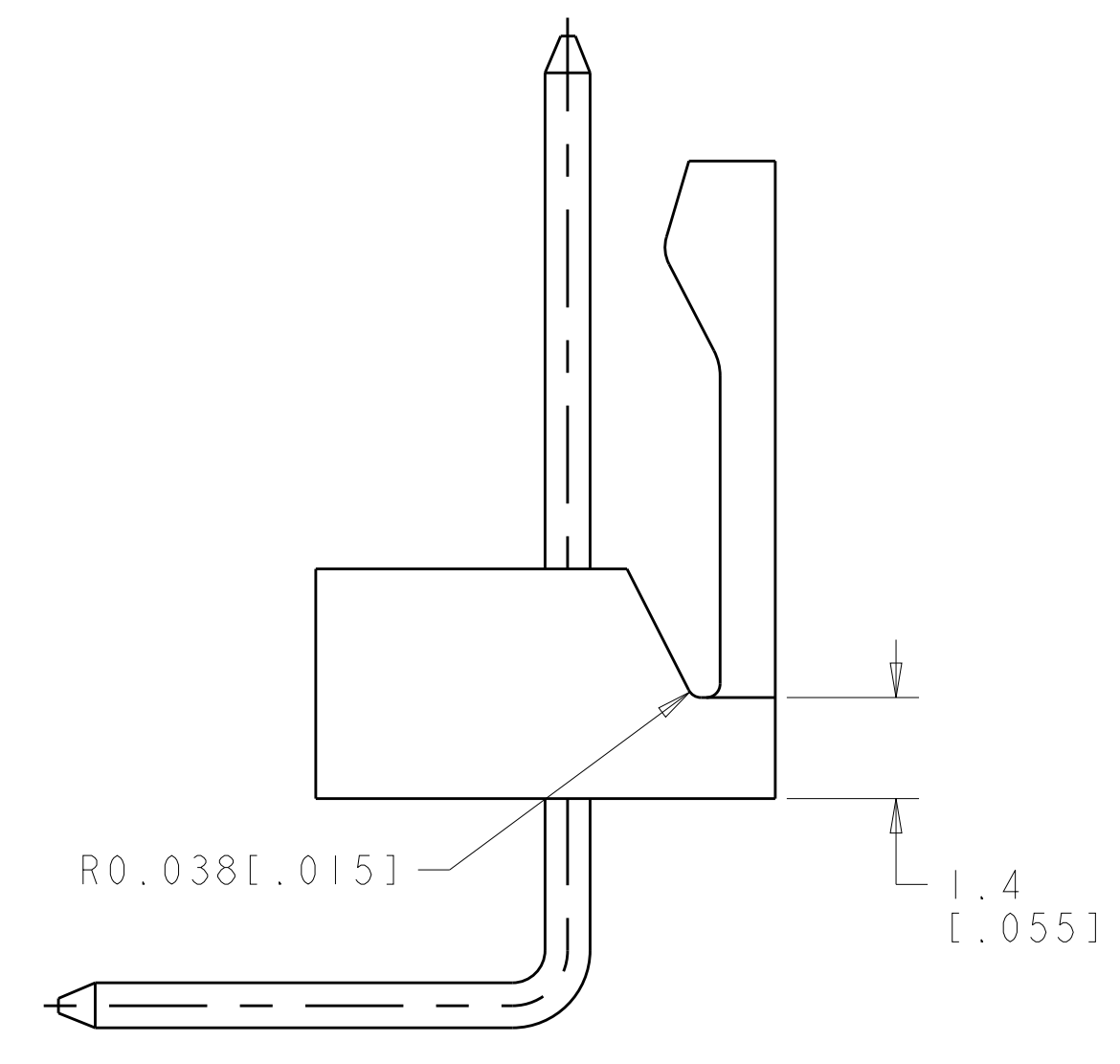

TYPICAL END VIEW FOR 4 THROUGH 7 POSITION

- △ POST WITHSTAND 13 NEWTONS (3 LBS) MIN AXIAL FORCE IN DIRECTION SHOWN WITHOUT DISLODGING.
- △ MEASURED AT [-A-].
- 3. PARTS COMPLY WITH SOLDERABILITY SPEC 109-11-2.
- △ MATERIAL:  
HOUSING: NYLON, 4/6, HIGH TEMP, BLACK.  
POST - COPPER ALLOY (SEE TABLE FOR PLATING).
- △ COORDINATE DIMENSION APPLIES FROM CENTER OF ACTUAL FEATURE.
- △ POSTS TO BE MEASURED WHEN STRIP HELD FLAT.
- 7. DIMENSIONS IN BRACKETS ARE IN INCHES.
- △ PLATING: GOLD PLATE AREA, 0.00076 [0.000030] GOLD OR 0.00008 [0.000003] MIN GOLD FLASH OVER 0.00068 [0.00027] PALLADIUM NICKEL, PER TE CONNECTIVITY'S DISCRETION, ALL SIDES, OVER NICKEL UNDERPLATE, 0.00127 [0.00050] MIN, ALL SIDES AND ENTIRE LENGTH OF POST.
- △ BRIGHT TIN/LEAD (93/7) PLATE AREA, 0.00381-0.00889 [0.00150-.000350] THICK, ALL FOUR SIDES, 3.56[.140] MIN.
- △ TOLERANCES APPLY TO SOLDER SIDE OF BOARD.
- △ ONE HOLE MAY BE UNDERSIZED 0.81-0.90 [0.32-.035] DIAMETER FOR ASSEMBLY RETENTION DURING PROCESSING.
- △ TE LOGO, UL, AND CSA TRADEMARKS TO APPEAR ON THIS SURFACE.
- △ MATTE TIN PLATE AREA, 0.00381-0.00889 [0.00150-.000350] THICK, ALL FOUR SIDES, 3.56[.140] MIN.
- △ OBSOLETE PARTS: OBSOLETE CIS STREAMLINING PER D.RENAUD/D.SINISI

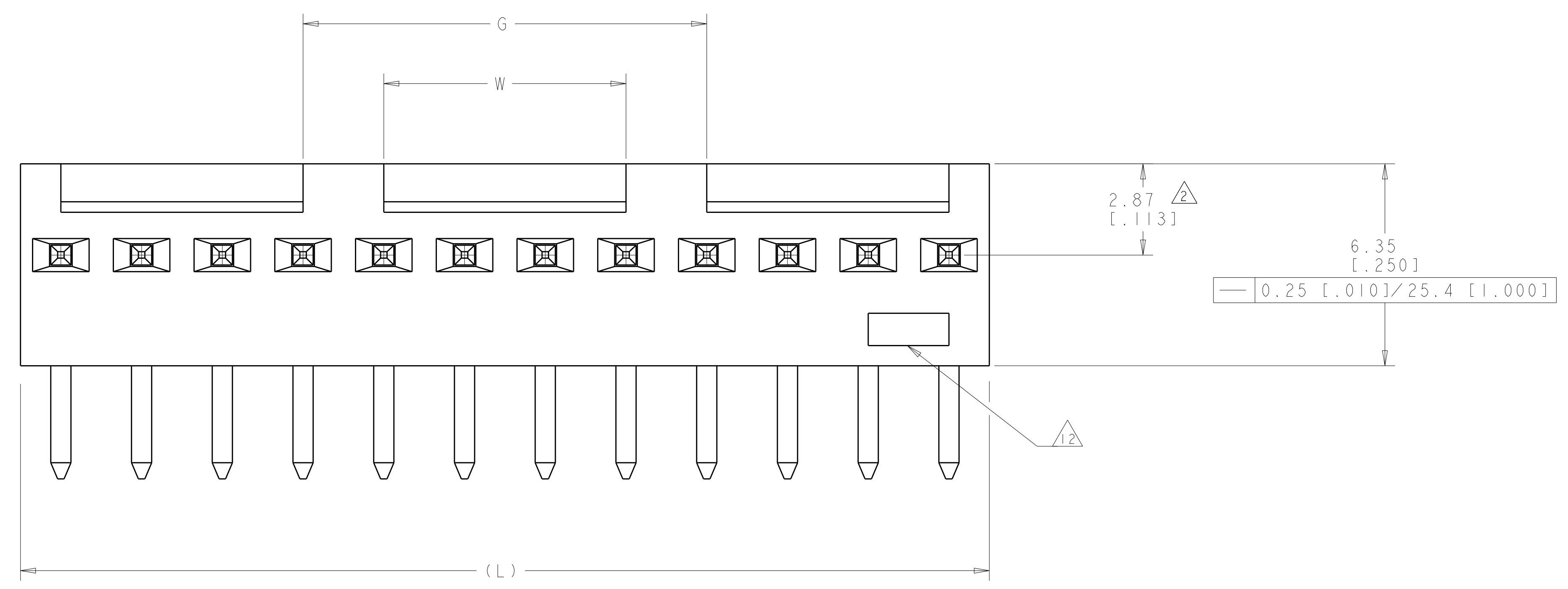
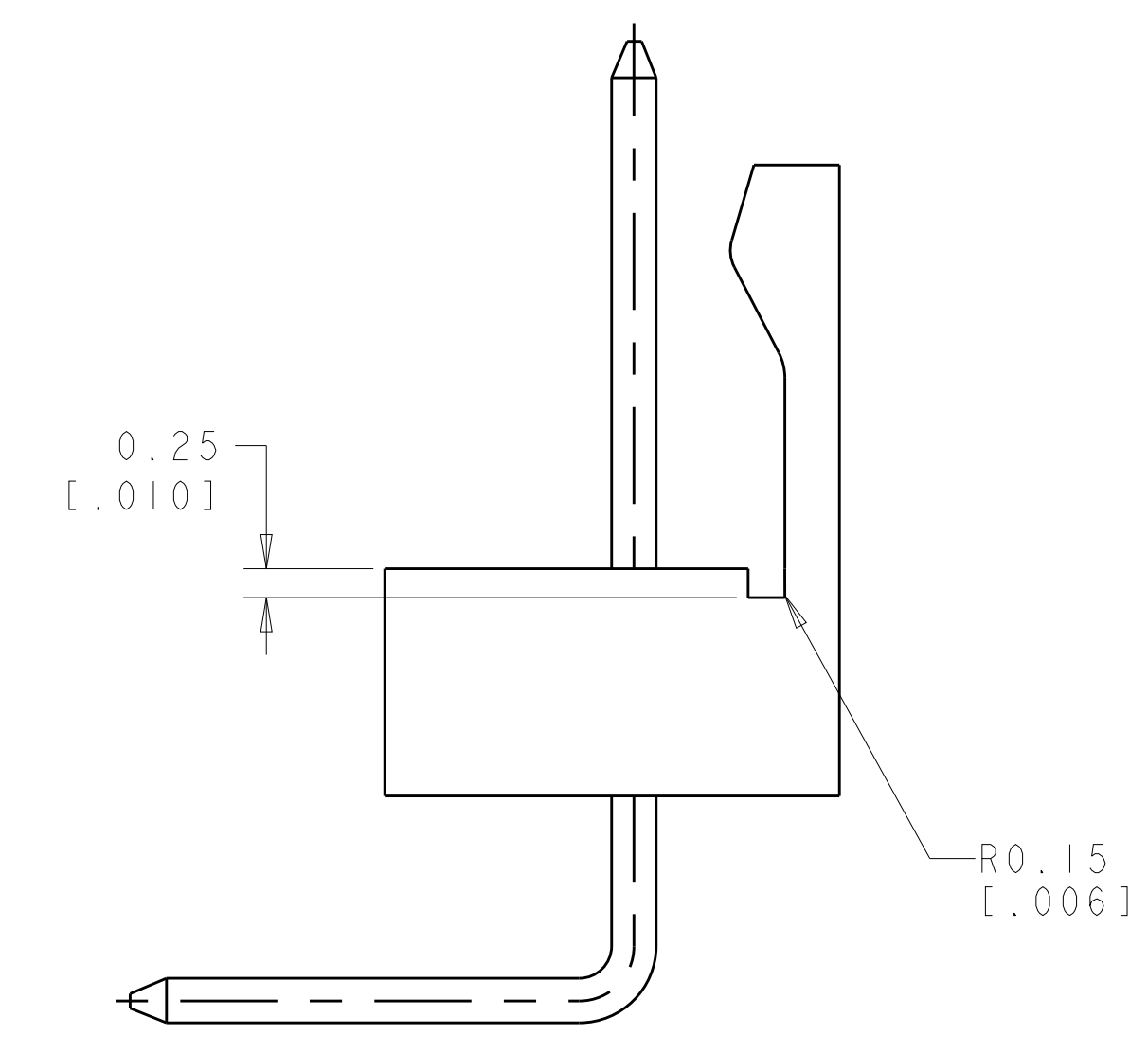
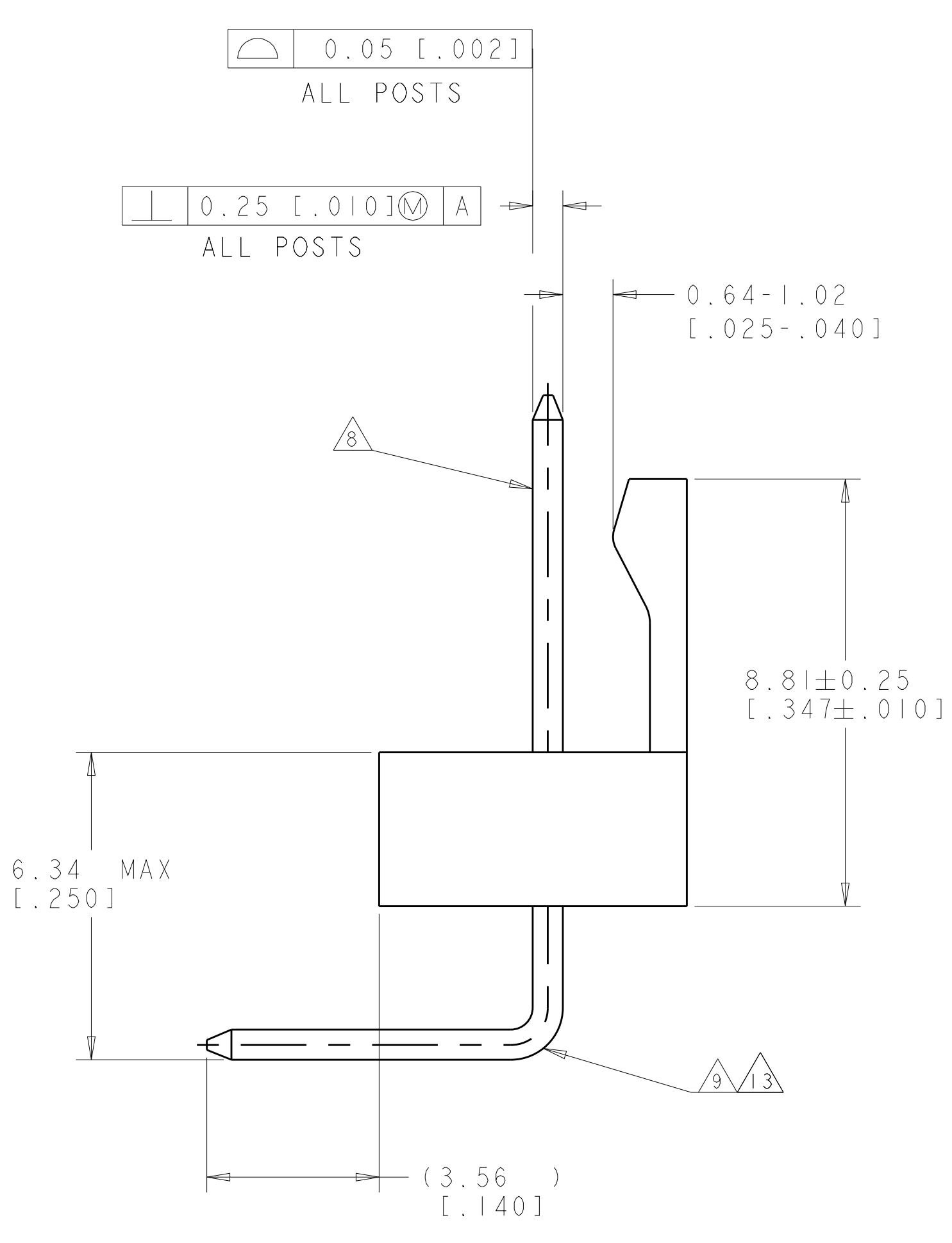
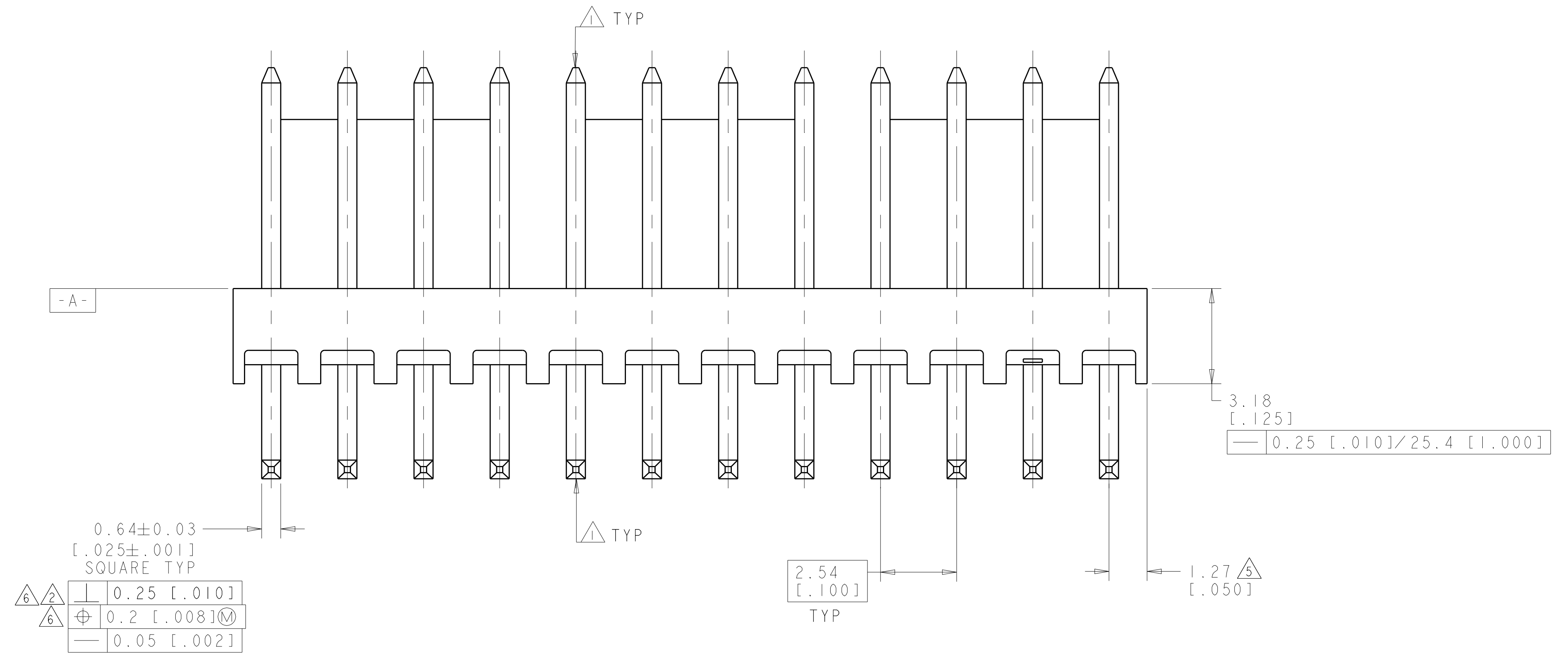

TYPICAL END VIEW FOR 2 POSITION ONLY

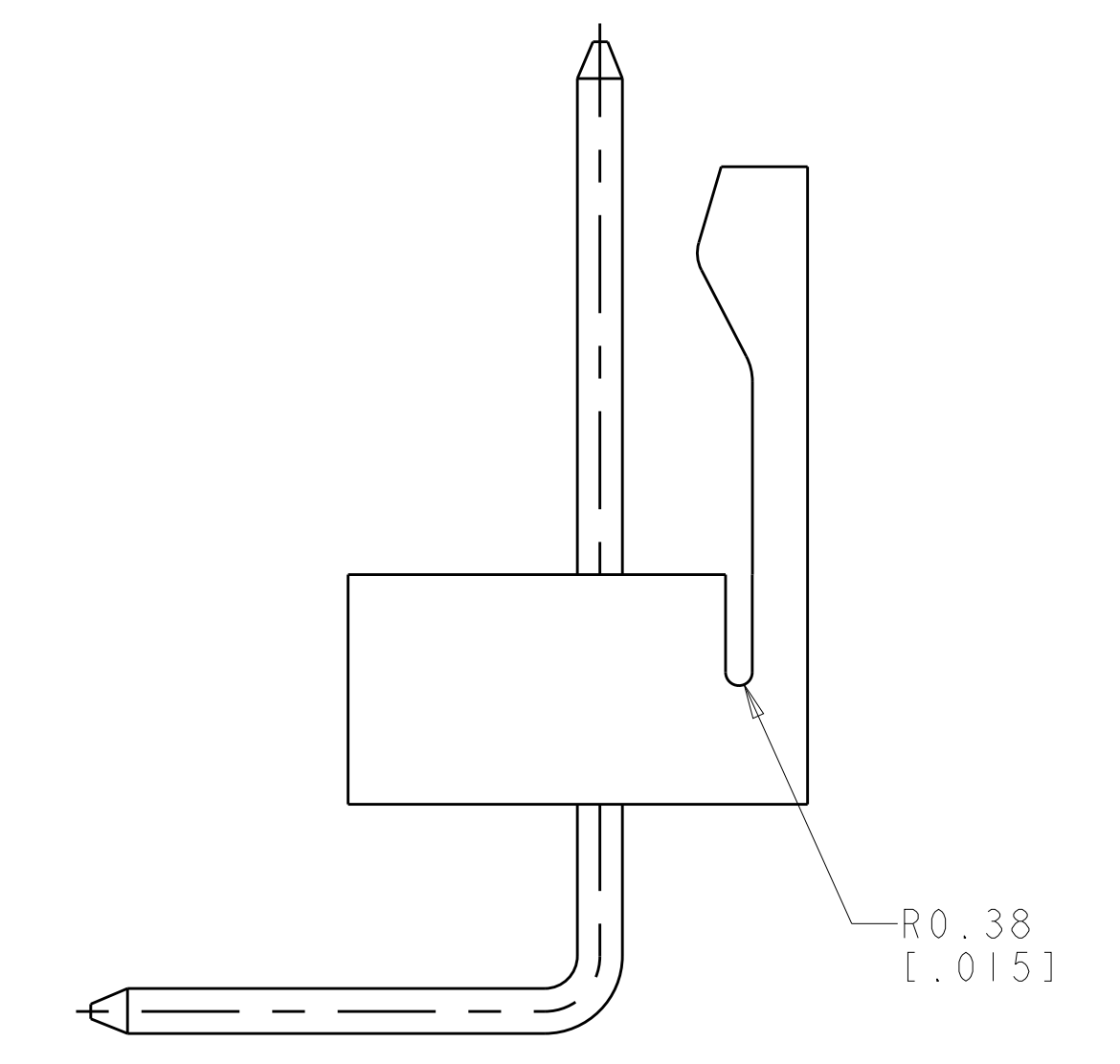

TYPICAL END VIEW FOR 3 POSITION ONLY

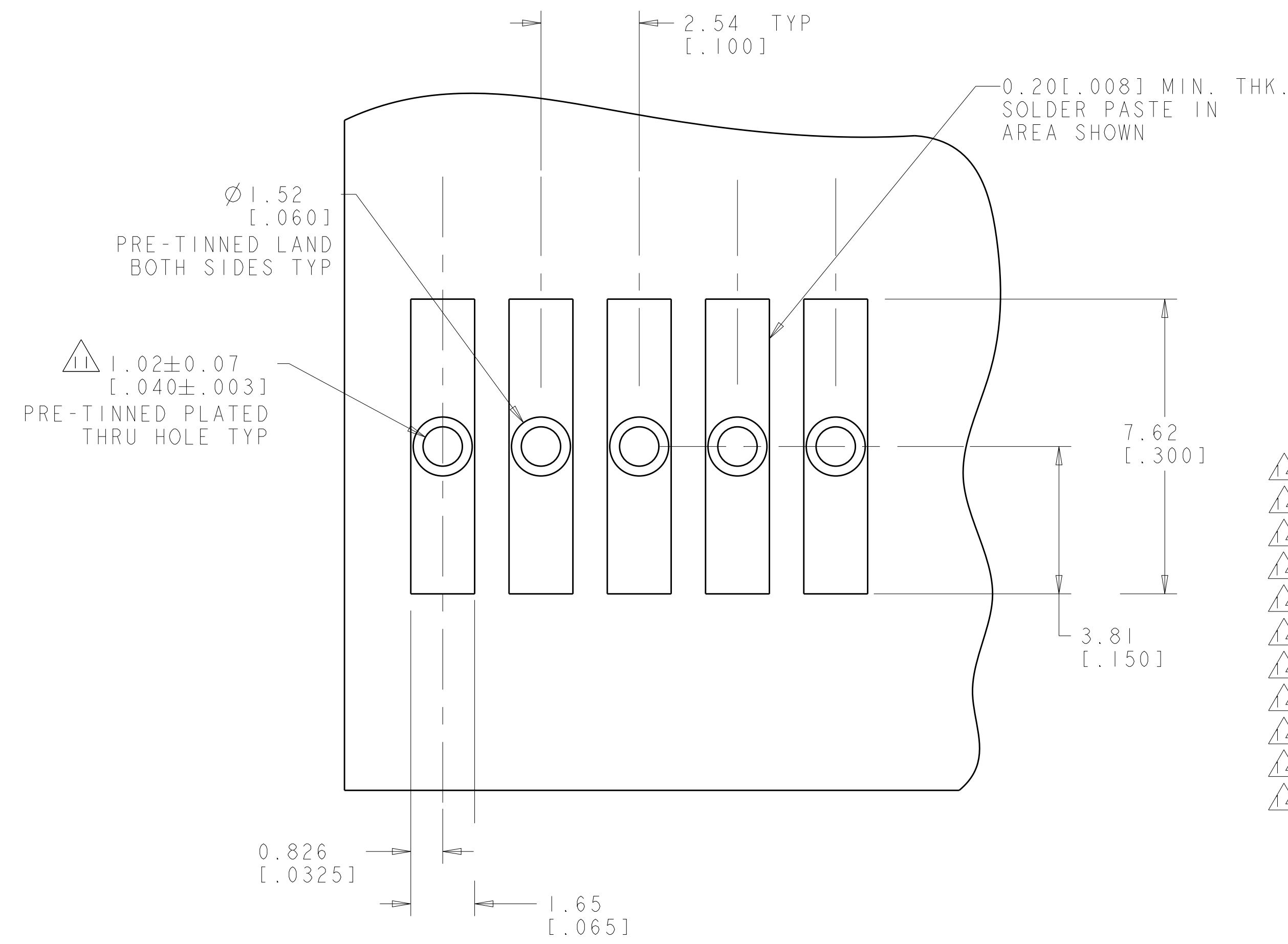
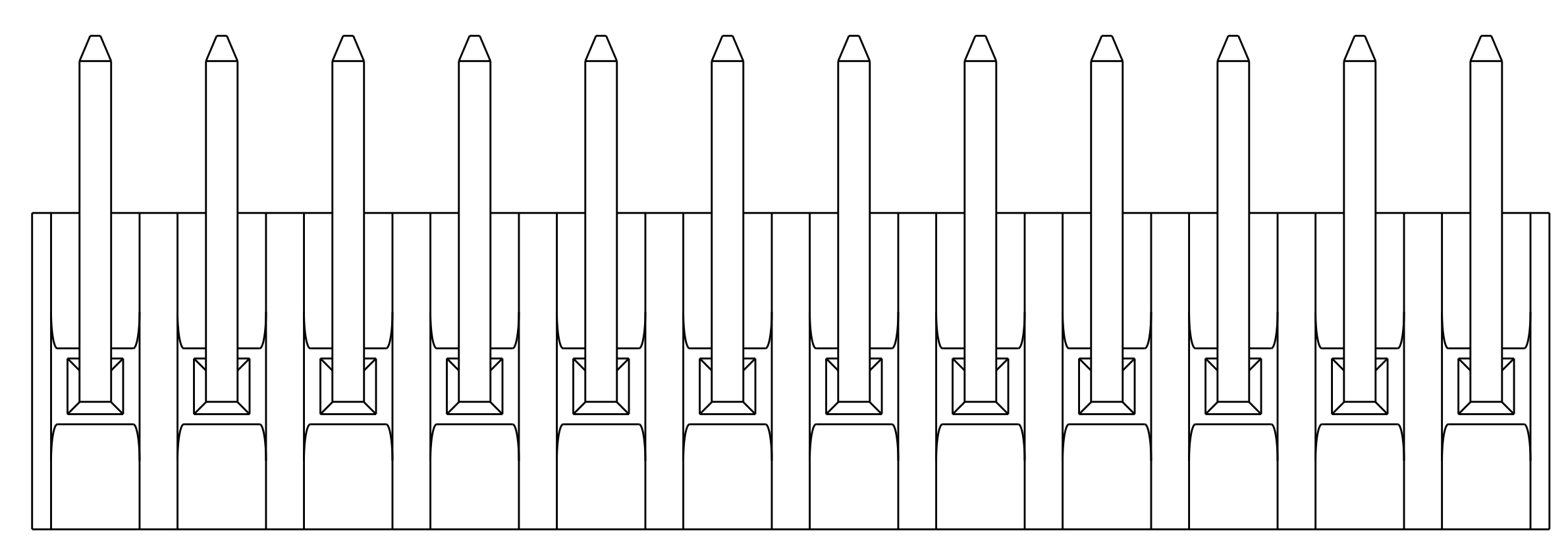

RECOMMENDED MOUNTING HOLE PATTERN FOR 1.57±0.20 [0.062±0.008] THICK P.C. BOARD

POST FINISH	W	G	L	NO OF POSN	PART NO
△	7.62 [0.300]	12.70 [0.500]	30.48 [1.200]	12	4-647117-2
	-	10.16 [0.400]	27.94 [1.100]	11	4-647117-1
	-	7.62 [0.300]	25.40 [1.000]	10	4-647117-0
	-	5.08 [0.200]	22.86 [0.900]	9	3-647117-9
	-	2.54 [0.100]	20.32 [0.800]	8	3-647117-8
	-	-	17.78 [0.700]	7	3-647117-7
	-	-	15.24 [0.600]	6	3-647117-6
	-	-	12.70 [0.500]	5	3-647117-5
	-	-	10.16 [0.400]	4	3-647117-4
	-	-	7.62 [0.300]	3	3-647117-3
	-	-	5.08 [0.200]	2	3-647117-2
	△	7.62 [0.300]	12.70 [0.500]	30.48 [1.200]	12
-		10.16 [0.400]	27.94 [1.100]	11	1-647117-1
-		7.62 [0.300]	25.40 [1.000]	10	1-647117-0
-		5.08 [0.200]	22.86 [0.900]	9	647117-9
-		2.54 [0.100]	20.32 [0.800]	8	647117-8
-		-	17.78 [0.700]	7	647117-7
-		-	15.24 [0.600]	6	647117-6
-		-	12.70 [0.500]	5	647117-5
-		-	10.16 [0.400]	4	647117-4
-		-	7.62 [0.300]	3	647117-3
-		-	5.08 [0.200]	2	647117-2

THIS DRAWING IS A CONTROLLED DOCUMENT. DATE: 3-NOV-2007. BY: J. WHITNEY. CHK: J. BOSS. DATE: 3-NOV-2007. APPD: J. BOSS. DATE: 3-NOV-2007.

TE Connectivity

MTA-100 HEADER ASSY HIGH TEMP. FRICTION LOCK .025 SQ. RIGHT ANGLE. FRONT BEND POST. 0.00030 GOLD.

SCALE: 10:1