

UC-2100 Series

Arm-based palm-sized wireless-enabled industrial computer with up to 2 serial ports and 2 LANs



- > ARMv7 Cortex-A8 600, 1000 MHz processor
- > 1 or 2 auto-sensing 10/100 Mbps Ethernet ports
- > Gigabit Ethernet supported by the UC-2112
- > Up to 2 software-selectable RS-232/422/485 ports supporting all signals
- > Moxa Industrial Linux with 10-year superior long-term support
- > Mini PCIe socket for Wi-Fi/Cellular module (UC-2104)
- > MicroSD socket for storage expansion (UC-2111/UC-2112)
- > Supports TPM v2.0
- > -40 to 75°C wide-temperature model available with hazardous locations certification (preliminary)



Overview

The UC-2100 Series computing platform is designed for embedded data acquisition and processing applications. The computer comes with up to two software selectable RS-232/422/485 full-signal serial ports and single or dual Ethernet LAN ports. This palm-size series of RISC computing platforms includes a variety of models for a wide range of interface requirements, such as single-to-dual serial and LAN ports, Gigabit Ethernet, and wireless connections. The versatile communication capabilities allow users to efficiently adapt the UC-2100 for a variety of complex communications solutions running on a compact palm-size computer.

The UC-2100 Series has a built-in Cortex-A8 RISC processor that has been optimized for a variety of industrial solutions. With flexible interface options, this tiny embedded computer is a reliable and secure gateway for data acquisition and processing at field sites and is a useful communication platform for many other large-scale deployments. Models designed for wide temperature applications are available for extreme environment applications such as those found in the Oil & Gas industry. Furthermore, all models use Moxa's industrial-grade Linux platform, which provides optimized software features and superior long-term support.

Appearance

UC-2101

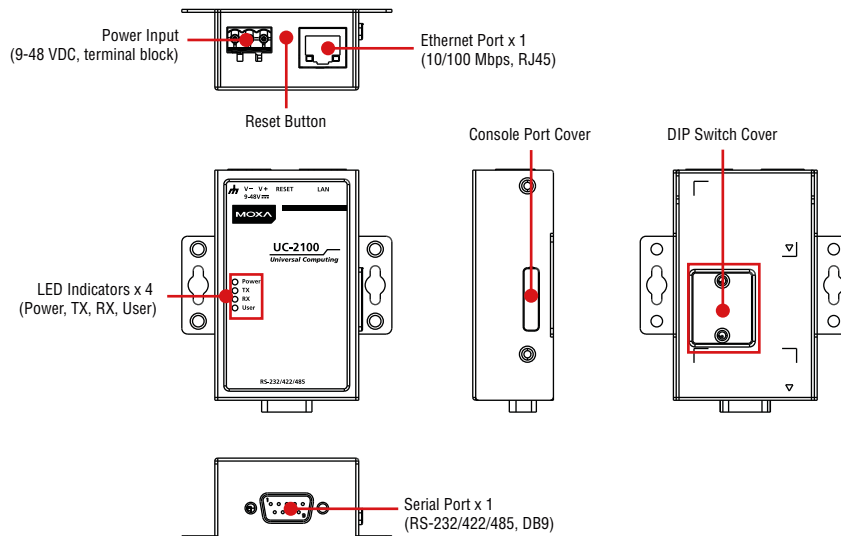

UC-2102

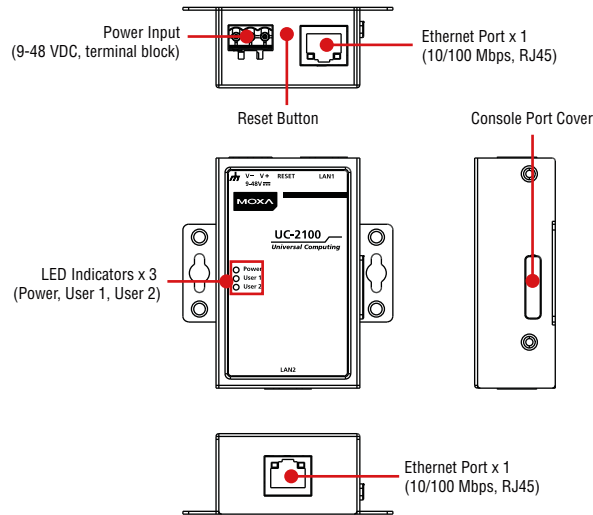

UC-2104

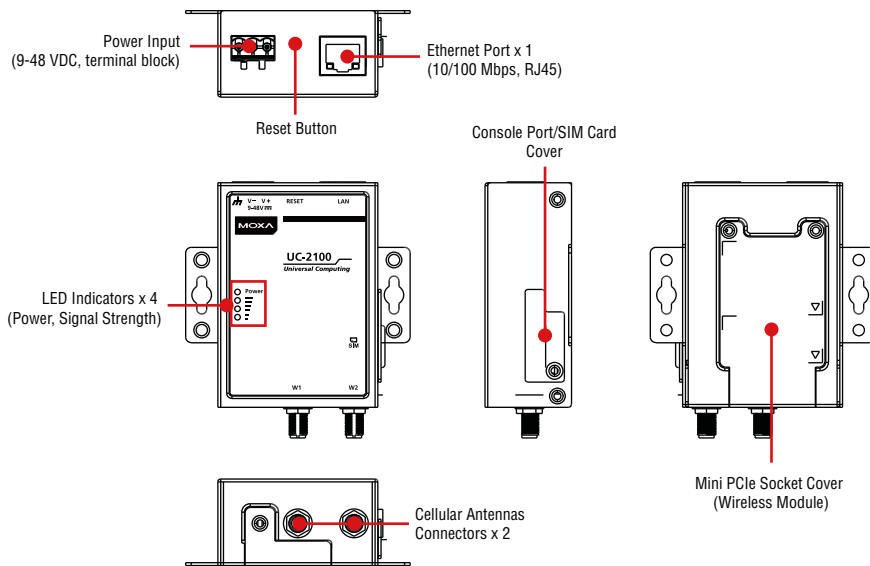

UC-2111

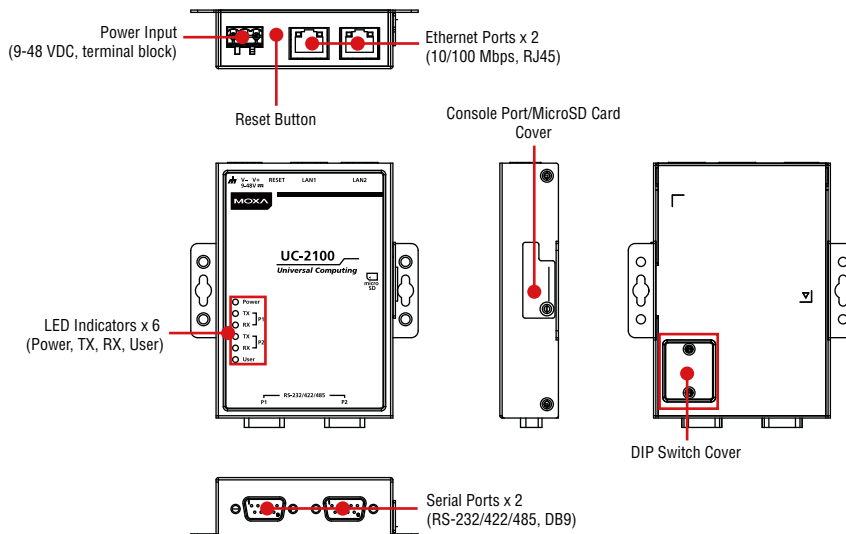

UC-2112

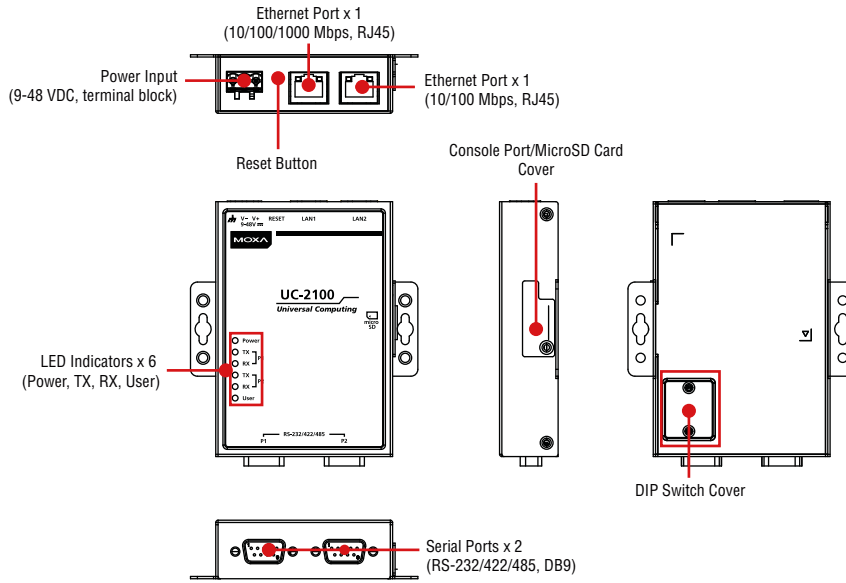

Dimensions

Unit: mm (inch)

UC-2101

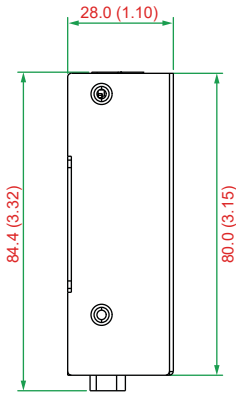

UC-2102

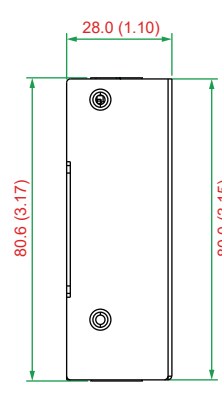

UC-2104

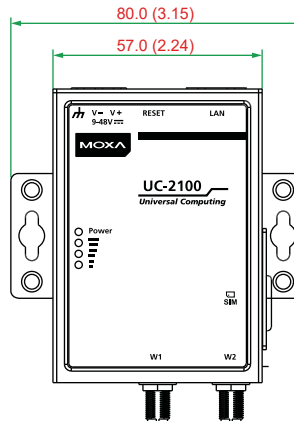
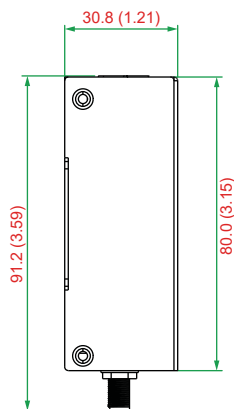

Dimensions

Unit: mm (inch)

UC-2111

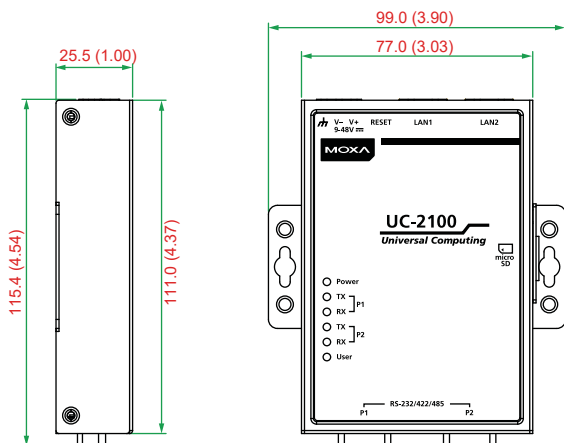

UC-2112

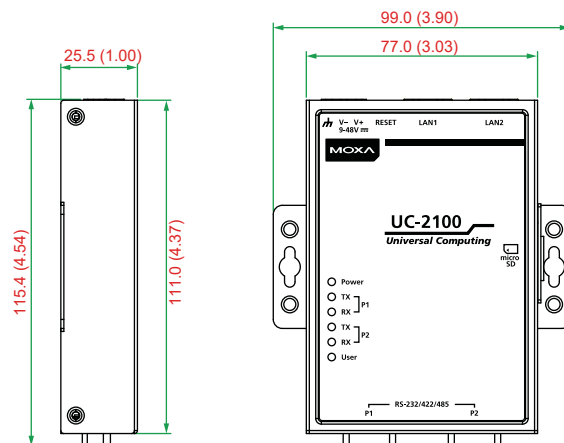

Hardware Specifications

Computer

CPU:

UC-2101/2102/2104/2111: ARMv7 Cortex-A8 600 MHz

UC-2112: ARMv7 Cortex-A8 1000 MHz

OS (pre-installed): Moxa Industrial Linux (Debian 9, Kernel 4.4)

DRAM:

UC-2101/2102/2104: 256 MB DDR3 SDRAM

UC-2111/2112: 512 MB DDR3 SDRAM

Storage

Built-in: 8 GB eMMC flash with OS pre-installed

Storage Expansion: SDHC/SDXC socket for storage expansion

(UC-2111/2112 only)

Other Peripherals

TPM: v2.0 by request (SPI interface)

Ethernet Interface

LAN:

UC-2101/2104: 1 auto-sensing 10/100 Mbps port (RJ45)

UC-2102/2111: 2 auto-sensing 10/100 Mbps ports (RJ45)

UC-2112: 1 auto-sensing 10/100 Mbps port (RJ45), 1 auto-sensing 10/100/1000 Mbps port (RJ45)

Magnetic Isolation Protection: 1.5 kV built-in

Serial Interface

Serial Standards:

UC-2101: 1 RS-232/422/485, software selectable port (DB9)

UC-2111/2112: 2 RS-232/422/485, software selectable port (DB9)

Console Port: RS-232 (TxD, RxD, GND), 4-pin pin header output (115200, n, 8, 1)

Serial Communication Parameters

Data Bits: 5, 6, 7, 8

Stop Bits: 1, 1.5, 2

Parity: None, Even, Odd, Space, Mark

Flow Control: XON/XOFF, ADDC® (automatic data direction control) for RS-485

Baudrate: 50 bps to 921.6 kbps

Serial Signals

RS-232: TxD, RxD, RTS, CTS, DTR, DSR, DCD, GND

RS-422: TxD+, TxD-, RxD+, RxD-, GND

RS-485-4w: TxD+, TxD-, RxD+, RxD-, GND

RS-485-2w: Data+, Data-, GND

LEDs

UC-2101:

System: Power x 1

LAN: LED located on the RJ45 connector, 10M/Link x 1, 100M/Link x 1

Serial: TxD x 1, RxD x 1

User Programmable: User x 1

UC-2102:

System: Power x 1

LAN: LED located on the RJ45 connector, 10M/Link x 2, 100M/Link x 2

User Programmable: User x 2

UC-2104:

System: Power x 1

LAN: LED located on the RJ45 connector, 10M/Link x 1, 100M/Link x 1

Wireless: Signal Strength x 3

UC-2111:

System: Power x 1

LAN: LED located on the RJ45 connector, 10M/Link x 2, 100M/Link x 2

Serial: TxD x 2, RxD x 2

User Programmable: User x 1

UC-2112:

System: Power x 1

LAN: LED located on the RJ45 connector

- LAN1: 100M/Link x 1, 1000M/Link x 1

- LAN2: 10M/Link x 1, 100M/Link x 1

Serial: TxD x 2, RxD x 2

User Programmable: User x 1

Switches and Buttons

Push Button: Initially configured to reboot and to reset the device to factory defaults

Dip Switch: For configuring the serial port Pull-High/Pull-Low and termination resistors

Physical Characteristics

Housing: SECC

Weight:

UC-2101/2102: 190 g (0.42 lb)

UC-2104: 220 g (0.49 lb)

UC-2111/2112: 290 g (0.64 lb)

Dimensions:

UC-2101: 50 x 80 x 28 mm
 UC-2102: 50 x 80 x 28 mm
 UC-2104: 57 x 80 x 30.8 mm
 UC-2111/2112: 77 x 111 x 25.5 mm

Mounting: Wall, DIN rail (with optional kit)

Environmental Limits

Operating Temperature:

Standard Models: -10 to 60°C (14 to 140°F)
 UC-2104: -10 to 70°C (14 to 158°F) w/ wireless module
 Wide Temp. Models: -40 to 75°C (-40 to 167°F)

Storage Temperature:

Standard Models: -20 to 70 °C (-4 to 158°F)
 Wide Temp. Models: -40 to 85°C (-40 to 185°F)

Ambient Relative Humidity: 5 to 95% (non-condensing)

Anti-Vibration: 2 Grms @ IEC 60068-2-64, random wave, 5-500 Hz, 1 hr per axis (without any USB devices attached)

Anti-Shock: 20 g @ IEC 60068-2-27, half sine wave, 11 ms

Power Requirements

Input Voltage: 9 to 48 VDC (3-pin terminal block, V+, V-, SG)

Input Current: 0.45 to 0.084 A

Power Consumption: 4 W (max.) (without cellular module)

Standards and Certifications

Safety: UL 60950-1, IEC 60950-1, EN 60950-1

EMC: 55032/24, RCM, VCCI, EAC

EMI: CISPR 32, FCC Part 15B Class A

EMS:

IEC 61000-4-2 ESD: Contact: 4 kV; Air: 8 kV
 IEC 61000-4-3 RS: 80 MHz to 1 GHz, 3 V/m
 IEC 61000-4-4 EFT: Power: 1 kV; Signal: 0.5 kV
 IEC 61000-4-5 Surge: DC Power: 0.5 kV; Signal: 1 kV
 IEC 61000-4-6 CS: 3V
 IEC 61000-4-8 PFMF: 1 A/m

Green Product: RoHS, CRoHS, WEEE

Reliability

Alert Tools: External RTC (real-time clock)

Automatic Reboot Trigger: External WDT (watchdog timer)

Warranty

Warranty Period: 5 years

Details: See www.moxa.com/warranty

Software Specifications

Linux

OS: Moxa Industrial Linux (Debian 9)

Web Server (Apache): Allows you to create and manage web sites; supports PHP and XML

Terminal Server (SSH): Provides secure encrypted communications between two untrusted hosts over an insecure network

Kernel: GNU/Linux 4.4 CIP

System Shell: DASH (default), BASH

Text Editor: vim, nano

File System: JFFS2, NFS, Ext3, Ext4, VFAT, OverlayFS, NTFS

Internet Protocol Suite: TCP, UDP, IPv4, IPv6, SNMPv2, v3, ICMP, ARP, HTTP, CHAP, PAP, DHCP, NTP, NFS, SSH, PPP, SFTP, RSYNC, SSL, SCP

Programming Language Support: PHP, Perl, Python

Internet Security Suite: OpenVPN, Netfilter/iptables, IPsec

Cryptographic Hardware Accelerators: AES, SHA, OpenSSL, random generator

Application Development Software:

- Toolchain ARM GNUeabihf 6.3
- GNU C/C++ cross-compiler
- GNU C library
- GDB source-level debugging server

Cellular Networking (UC-2104):

- WVDIAL: Point-to-Point Protocol dialer that dials a modem and starts pppd to connect to the Internet
- QMI (Qualcomm MSM Interface): Glib-based library for talking to WWAN modems and devices that speak the Qualcomm MSM Interface (QMI) protocol
- Modem Manager
- Cellular Management Utility
- Wi-Fi Management Utility

Moxa Industrial Linux

Long-Term Support: Moxa Industrial Linux allows users to keep the same kernel version and Debian user space without needing to upgrade the entire system frequently. In addition, subscription services for each major release of Moxa Industrial Linux, throughout its 10-year life-cycle phase, provide security updates and bug fixes

Robust File system: The OverlayFS robust file system integrated into Moxa Industrial Linux provides extra protection during firmware upgrades and downgrades.

Cybersecurity:

- Moxa Industrial Linux comes with a built-in utility that helps developers implement a cybersecurity protection mechanism based on IEC 62443-4-2 international standards
- Security Update of Existing Software Packages: All software packages installed on the UC-2100 Series can be automatically updated using Debian Linux's Advanced Packaging Tool (APT) server or Moxa's server

Real COM Mode: Support NPort's Real COM mode driver to communicate with NPort device servers

Ordering Information

Model	CPU	RAM	Storage	Serial	Ethernet	Micro SD	Mini PCIe	Operating Temperature
UC-2101-LX	600 MHz	256 MB	8 GB	1	1	–	–	-10 to 60°C
UC-2102-LX	600 MHz	256 MB	8 GB	–	2	–	–	-10 to 60°C
UC-2104-LX	600 MHz	256 MB	8 GB	–	1	–	1	-10 to 70°C
UC-2111-LX	600 MHz	512 MB	8 GB	2	2	1	–	-10 to 60°C
UC-2112-LX	1000 MHz	512 MB	8 GB	2	2 (1 Giga LAN)	1	–	-10 to 60°C
UC-2112-T-LX	1000 MHz	512 MB	8 GB	2	2 (1 Giga LAN)	1	–	-40 to 75°C

Optional Accessories (can be purchased separately)

Power Adapters, Power Cords

Model Name	Package Contents	Description
PWR-24270-DT-S1	• 1 x Power adapter	Power adapter for testing and system development indoors under ambient temperature conditions (input: 100 to 240 VAC, 50 to 60 Hz, 1.5 A; output: 24 VDC, 2.7 A, 60 W)
PWC-C7US-2B-183	• 1 x Power cord	10 A/125 V North American (US) power cord, 183 cm
PWC-C7EU-2B-183	• 1 x Power Cord	10 A/250 V Continental European (EU) power cord, 183 cm
PWC-C7UK-2B-183	• 1 x Power Cord	10 A/250 V United Kingdom (UK) power cord, 183 cm
PWC-C7AU-2B-183	• 1 x Power Cord	2.5 A/250 V Australian (AU) power cord, 183 cm
PWC-C7CN-2B-183	• 1 x Power Cord	10 A/250 V China (CN) power cord, 183 cm

Wireless Packages

Model Name	Package Contents	Description
UC-LTE-CAT1-EU	• 1 x Cellular module • 2 x Mini PCI/e mount screw sets	LTE regions: Asia, Europe Penta-Band LTE: Bands 1, 3, 8, 20, 28 (700, 800, 900, 1800, 2100 MHz), Dual-Band GSM 900 and 1800 MHz
UC-LTE-CAT1-AUS	• 1 x Cellular module • 2 x Mini PCI/e mount screw set	LTE regions: Australia, New Zealand Quad-Band LTE: Bands 3, 5, 8, 28 (1800, 850, 900, 700 MHz), Tri-Band UMTS: Bands 1, 5, 8 (WCDMA/FDD 2100, 850, 900 MHz)
UC-LTE-CAT4-CN	• 1 x Cellular module • 2 x Mini PCI/e mount screw set	LTE(FDD): B1,B3,B8; LTE(TDD): B39,B40,B41(38), all bands with diversity DC-HSPA+: B1,B9,B5,B8; TDS: B34, B39, all bands with diversity GSM: 1800/900MHz
UC-WiFi-USB	• 1 x WiFi module • 2 x Mini PCI/e mount screw set	Operating Frequency: 802.11 ac/a/b/g/n ISM Band 2.412 GHz to 2.472 GHz, 5.180 MHz to 5.825 MHz (Subject to local regulations) Modulation: 802.11b: DSSS (DBPSK, DQPSK, CCK) 802.11a/g: OFDM (BPSK, QPSK, 16-QAM, 64-QAM) 802.11n: OFDM (BPSK, QPSK, 16-QAM, 64-QAM) 802.11ac: OFDM (BPSK, QPSK, 16-QAM, 64-QAM, 256-QAM)

Antennas and Internal Antenna Cables

Model Name	Package Contents	Description
ANT-WDB-ARM-0202 plus ADP	• 1 x WiFi antenna • 1 x SMA adapter	1.8/1.8 dBi, RP-SMA (male) antenna with 1 SMA adapter
ANT-LTE-OSM-03-3m BK	• 1 x LTE antenna	Multi-band antenna that covers 700-2700 MHz. Specially designed for 2G, 3G, and 4G applications. Magnetic mounting is available.
ANT-LTE-ASM-04 BK	• 1 x LTE antenna	LTE Stick antenna that covers 704-960/1710-2620 MHz providing omnidirectional radiation with a gain of 4.5 dBi.
ANT-LTE-ASM-05 BK	• 1 x LTE antenna	LTE stick antenna that covers 704-960/1710-2620 MHz with a gain of 5 dBi.
ANT-LTE-OSM-06-3m BK MIMO	• 1 x LTE antenna	Multi-band antenna that covers 700-2700/2400-2500/5150-5850 MHz frequencies. Screw-fastened mounting and full IP67 waterproofing are available.
SMA-Adapter	• 1 x SMA adapter	SMA Adapter for UC-2104 to convert to SMA male connector

DIN-Rail Kits

Model Name	Package Contents	Description
DK35A	• 2 x Mounting kit	DIN-rail kit with screws

Package Checklist

- UC-2100 embedded computer
- Power jack
- Console cable
- Quick installation guide (printed)
- Warranty card