

LOC	DIST	P	F	ZONE	LTR	DESCRIPTION	DATE	APPD
AJ	16				O	RLSE -1 PER 96-3972-013	6-4-96	JL
					A	REV PER 0503-0181-96	9-26-96	JL
					B	RLSE -2 PER 0630-0303-98	29JUL98	MO

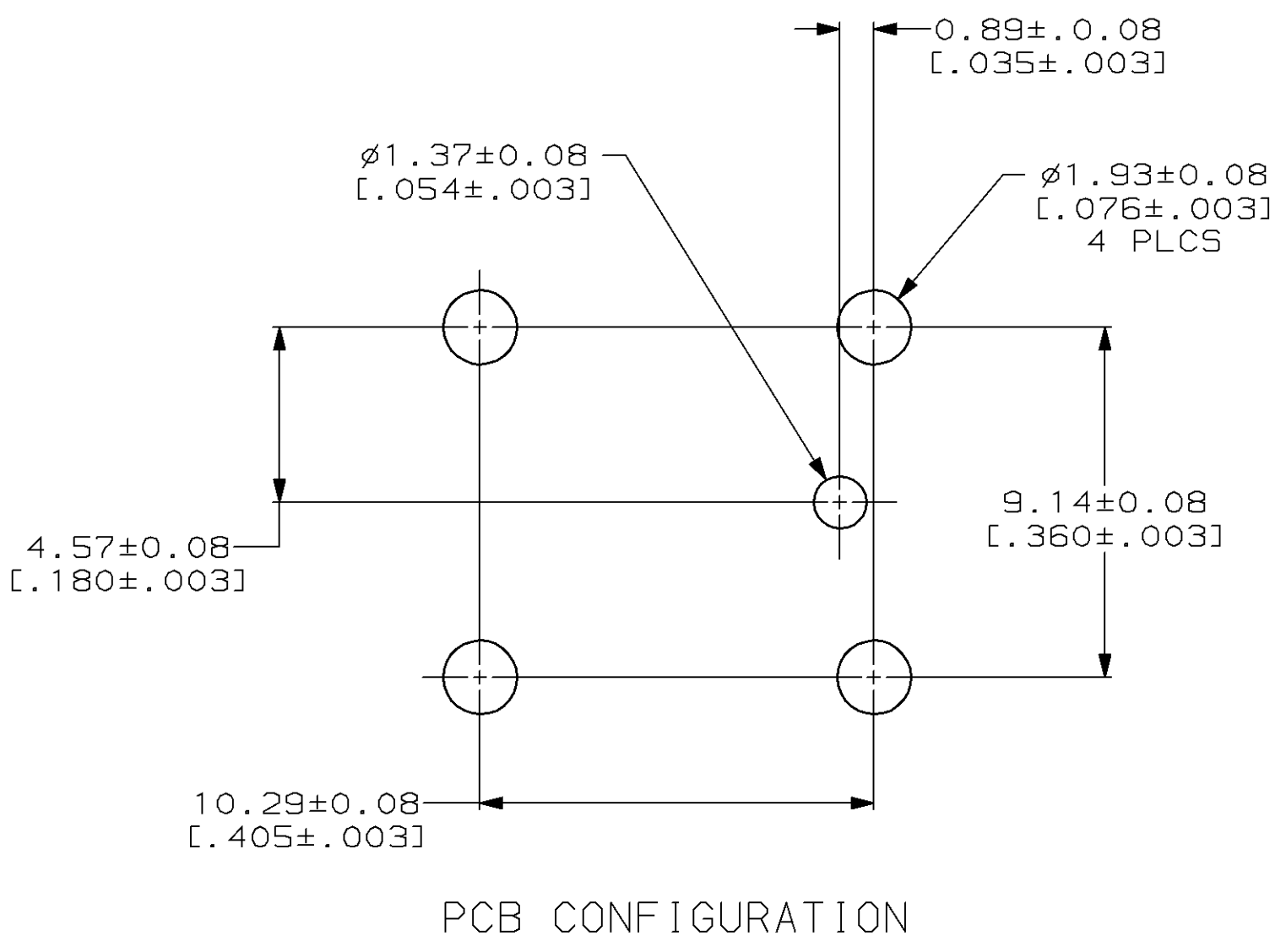
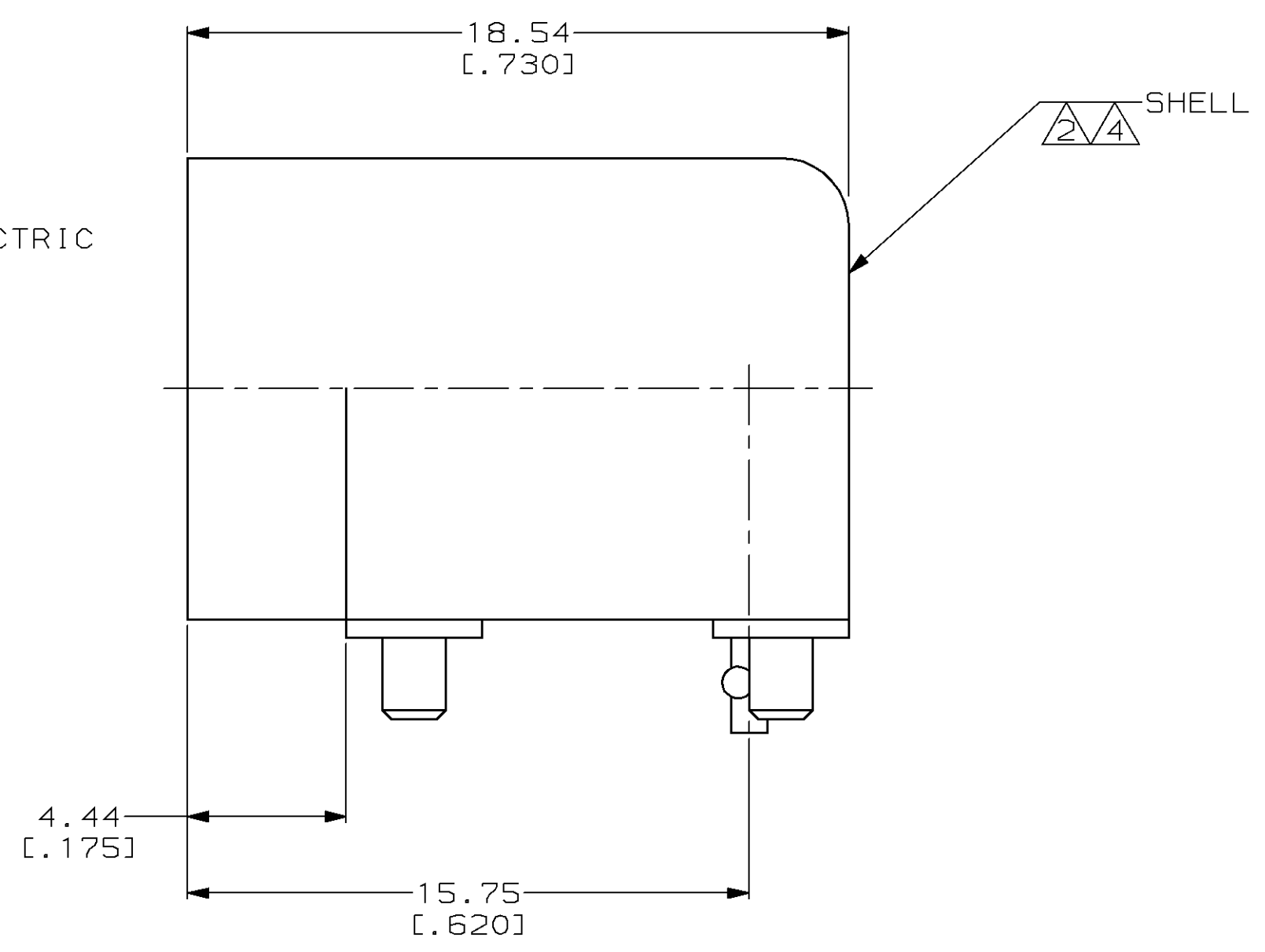
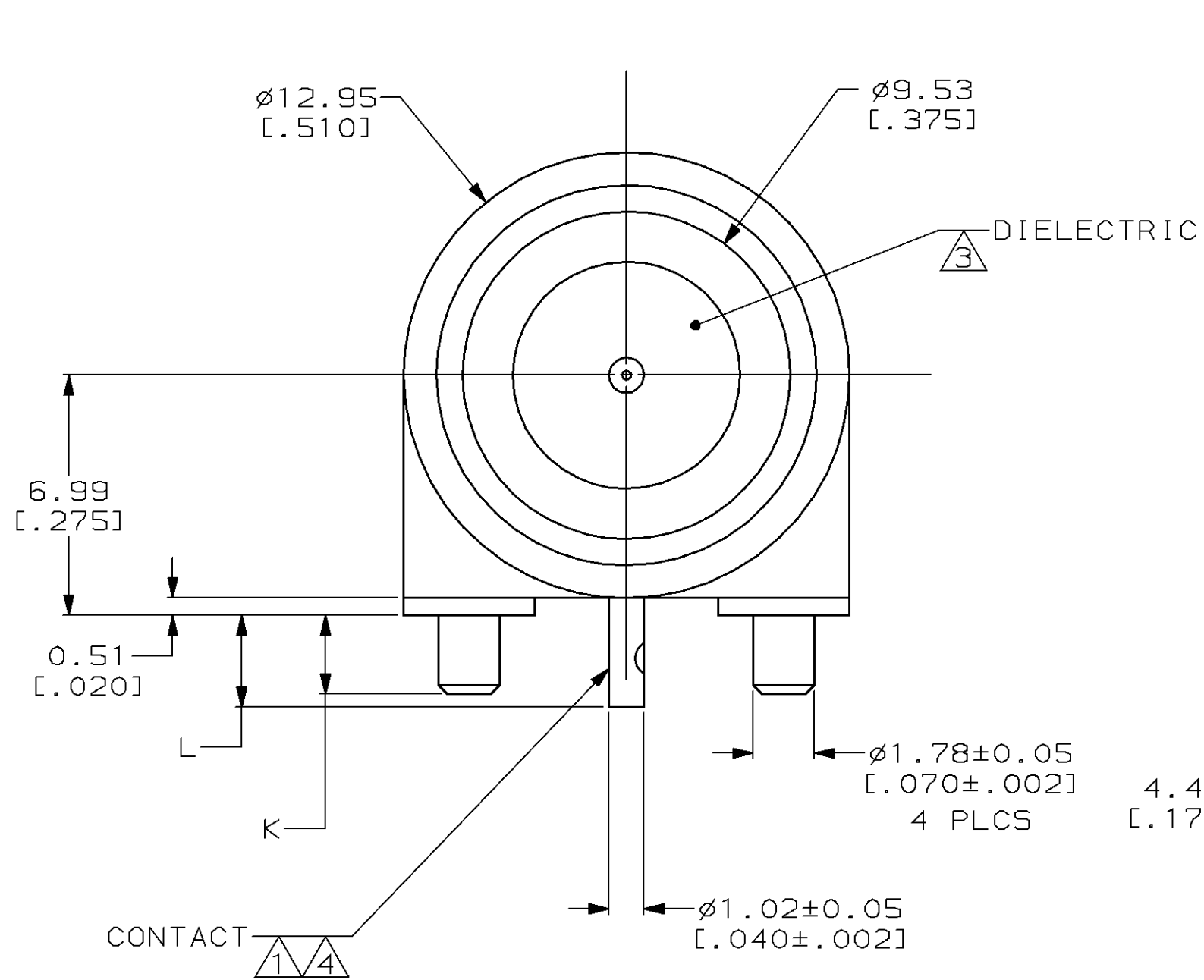

- 1 BRASS PER ASTM-B-16
- 2 ZINC PER QQ-Z-363.
- 3 POLYPROPYLENE, GENERAL PURPOSE
- 4 TIN-LEAD PLATE PER ASTM-B-545
3.81 μm [0.000150] MINIMUM THICK.
- 5. TEST JACK INSERTION DEPTH TO BE .450 IN

3.30 [0.130]	3.30 [0.130]	415406-2
2.29 [0.090]	2.67 [0.105]	415406-1
K	L	PART NUMBER

DO NOT SCALE PRINT. UNLESS SPECIFIED DIMENSIONS IN mm [INCHES] TOLERANCES ON:		DR 5-29-96 J. LIPPERT		PART NO	
2 PLC DEC ± -		CHK 6-4-96 K. WEIDNER		AMP Incorporated Harrisburg, PA 17105-3608	
3 PLC DEC ± 0.20 [0.008]		APPD 6-4-96 K. WEIDNER			
ANGLES ± -		APPD 6-4-96 J. LIPPERT		NAME	
MATERIAL		PRODUCT SPEC		TEST PLUG, PCB, RIGHT ANGLE, G SERIES	
SEE NOTES 1 THRU 5		-			
FINISH		APPLICATION SPEC		SIZE	CAGE CODE
SEE NOTE 6		-		C	00779
		WEIGHT		DRAWING NO	
		-		C=415406	
				SCALE	SHEET
				6:1	1 OF 1

THIS DRAWING IS A CONTROLLED DOCUMENT FOR AMP INCORPORATED. IT IS SUBJECT TO CHANGE AND THE CONTROLLING ENGINEERING ORGANIZATION SHOULD BE CONTACTED FOR THE LATEST REVISION.