

PART NUMBER	REV	TERMINATOR	FEED TYPE	DESCRIPTION
1529213-1	B	BENCH & LEADMAKER	MECH POST FEED	HDI APPLICATOR
7-1529213-1	B	BENCH & LEADMAKER	MECH POST FEED	-1 AND SPARE PARTS
7-1529213-7	A	-	-	SPARE PARTS KIT

LOC	DIST	REV	DATE	BY	APPV
A	66	A	14FEB2007	DP	MC
		B	18JUL2008	MY	TE

CRIMP DATA TE TERMINAL TE CRIMP SPECS

TERMINAL NAME: .110 SERIES FASTIN-ON TAB

CRIMP	SIZE	TYPE	RANGE
WIRE	2.29 [.090 IN]	F	0.50mm <sup>2</sup> -1.50mm <sup>2</sup>
INSUL	3.30 [.130 IN]	F	2.30-3.00 [.090-.120 IN]

WIRE STRIP LENGTH 3.90-4.70 [.154-.185 IN] APPL INSTRUCTIONS 408-8323 & 408-8490

TERMINAL 114-20021 FEED 23.75 [.935 IN]  
 APPL SPEC -

TERMINALS APPLIED

WIRE SIZE	CRIMP HEIGHT	REF SETTING
1.50mm <sup>2</sup>	1.75 ±0.05 [.069 ±.002 IN]	B7
1.00mm <sup>2</sup>	1.57 ±0.05 [.062 ±.002 IN]	D1
0.75mm <sup>2</sup>	1.52 ±0.05 [.060 ±.002 IN]	D4
0.50mm <sup>2</sup>	1.47 ±0.05 [.058 ±.002 IN]	D6

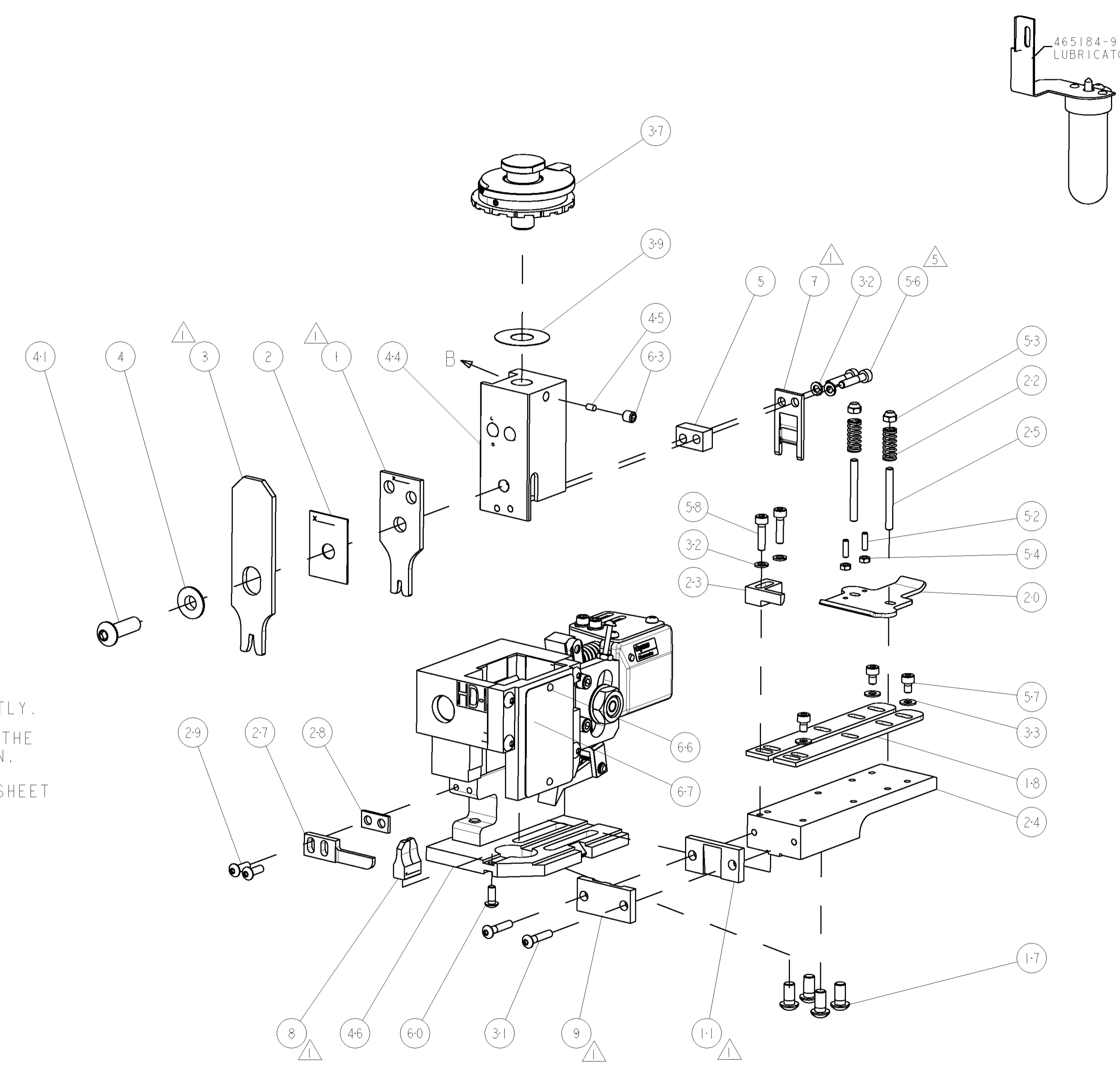

- 1 RECOMMENDED SPARE PARTS
- 2 GREASE RAM, CAM, CAM FOLLOWER AND FEED ROD LIGHTLY.
- 3 CERTAIN TERMINALS REQUIRE LUBRICATION. REFER TO THE APPLICATOR INSTRUCTION SHEET FOR MORE INFORMATION.
- 4 LUBRICATE DAILY PER THE APPLICATOR INSTRUCTION SHEET SUPPLIED WITH THE APPLICATOR.
- 5 ITEM 56, CUT TO LENGTH AT ASSEMBLY.

**\* WARNING**  
 ON INSTALLATION, SET WIRE DISC TO LARGEST WIRE SIZE SETTING. USE OF SETTINGS BELOW MIN. REQUIRED CRIMP HEIGHT SETTING WILL CAUSE DAMAGE TO CRIMP TOOLING.

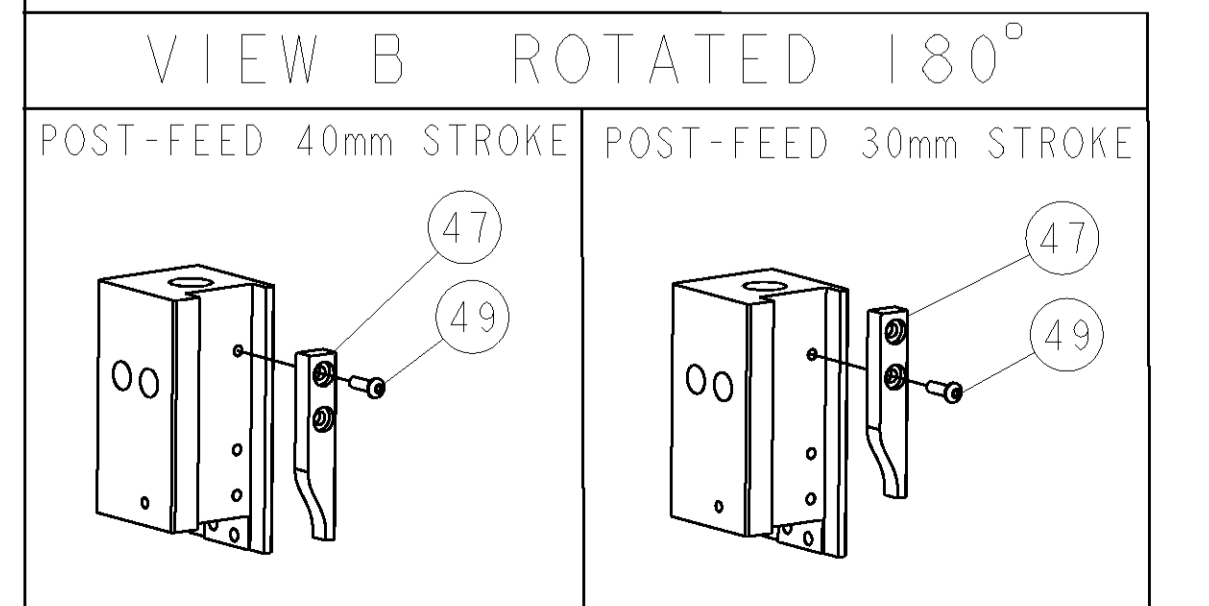

-	1	1	1338705-4	DOCUMENTATION PACKAGE	71
-	1	1	461264-5	PLATE, IDENTIFICATION	67
-	2	2	21017-2	SCREW, DRIVE	66
-	1	1	3-18031-0	SCR, SET, CUP POINT M6 X 6.0	63
-	1	1	18024-7	SCR, BTN SKT HD CAP (M4 X 10.0)	60
-	2	2	1-18023-3	SCR, SKT HD CAP M4 X 16.0	58
-	3	3	18023-9	SCR, SKT HD CAP M4 X 6.0	57
-	2	2	1-18023-4	SCR, SKT HD CAP M4 X 20.0	56
-	2	2	18029-1	NUT, HEX, REG M3	54
-	2	2	986965-1	NUT, LOCK, HEX, TORQUE (M4)	53
-	2	2	2-18032-2	SCR, SET, FLT POINT M3 X 10.0	52
-	1	1	18024-3	SCR, BTN SKT HD CAP (M3 X 10.0)	49
-	1	1	1338676-1	CAM, UNIVERSAL POST-FEED	47
-	1	1	1338662-1	SUB ASSY, APPLICATOR FRAME	46
-	1	1	690191-1	PLUG, NYLON	45
-	1	1	1320998-1	RAM	44
-	1	1	2-18024-6	SCR, BTN SKT HD CAP (M8 X 25.0)	41
-	1	1	690125-1	SHIM SUB-ASSY	39
-	1	1	879103-2	FINE ADJUST HEAD ASSEMBLY	37
-	3	3	18027-2	WASHER, FLAT, REG M4	33
-	4	4	18025-2	WASHER, SPRG LOCK, REG M4	32
-	2	2	1-18024-0	SCR, BTN SKT HD CAP (M4 X 20.0)	31
-	2	2	18024-8	SCR, BTN SKT HD CAP (M4 X 12.0)	29
-	1	1	3-690451-2	SPACER, STRIPPER	28
-	1	1	240639-1	STRIPPER (MACHINING)	27
-	2	2	1320906-1	STUD, THREADED	25
-	1	1	1320995-1	PLATE, STRIP GUIDE	24
-	1	1	240825-2	PLATE, STRIP HOLD DOWN	23
-	2	2	4-22281-1	SPRING, DRAG	22
-	1	1	1338665-1	DRAG	20
-	2	2	1338663-5	GUIDE, LOWER STRIP	18
-	4	4	1-18024-8	SCR, BTN SKT HD CAP (M6 X 12.0)	17
-	1	1	240644-1	PLATE, REAR SHEAR	11
-	1	1	690482-5	PLATE, FRONT SHEAR	9
-	1	2	1-1333217-7	ANVIL, EF .090	8
-	1	1	690474-5	BLADE, SLUG	7
-	-	-	-	-	6
-	1	1	8-240641-5	SPACER	5
-	1	1	238009-1	BLOCK, FL CRIMPER SPACER	4
-	1	2	1-456134-9	CRIMPER, INSULATION F PREMIUM	3
-	1	1	455888-6	SPACER, CRIMPER	2
-	1	2	4-456406-7	CRIMPER, WIRE PREMIUM	1

DIMENSIONS: INCHES		TOLERANCES UNLESS OTHERWISE SPECIFIED:		DWN D. PROUSE 16JAN2007		Tyco Electronics Harrisburg, PA 17105-3608	
0 PLC ±.1 1 PLC ±0.1 2 PLC ±0.01 3 PLC ±0.001 4 PLC ±0.0001 ANGLES ±.1		FINISH		APVD M. CLIFFORD 16JAN2007		NAME: FINE ADJUST END FEED HDI APPLICATOR	
MATERIAL		FINISH		WEIGHT		SIZE: CAGE CODE: DRAWING NO: 00779 C=1529213	
CUSTOMER DRAWING		SCALE: 3:5		SHEET 1 OF 1		REV B	