

- NOTES:
- 1 - HOUSING MATERIAL: GLASS FILLED POLYESTER, UL 94V-0. COLOR: BLACK
 - 2 - TERMINAL MATERIAL: PHOSPHOR BRONZE
 - 3 - SEE ADDITIONAL SHEETS FOR CHARTS, PLATINGS, AND OVERALL DIMENSIONS
 - 4 - THIS PRODUCT CONFORMS TO PS-70181.

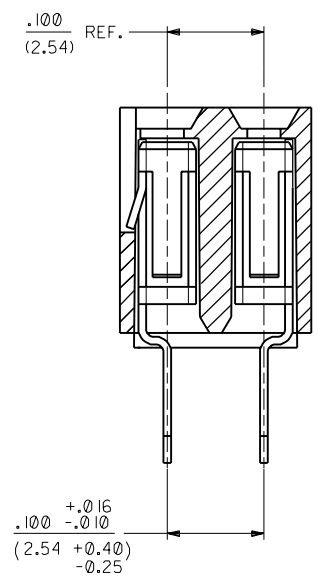
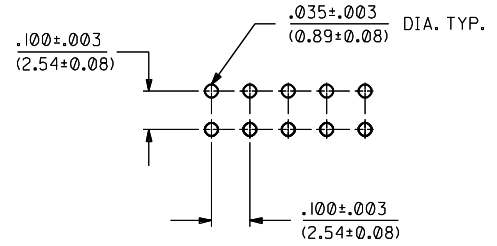

B	CHANGE PACK SPEC. ECN# UDT2000-0503 DMORGAN 99/12/14		
A	REVISE PLATE & BOX REL. DWG U30572 09/08/93 MURPHY		
2	B		
1	B		
MFG. SH.	REV.	LTR.	REVISIONS

DIMENSIONS SHOWN (METRIC) INCH
UNLESS OTHERWISE SPECIFIED
TOLERANCES ANGULAR $\pm 1/2^\circ$

	INCH	METRIC
3 PLACE	$\pm .010$	---
2 PLACE	$\pm .014$	± 0.25
1 PLACE	---	± 0.35

DRAFT WHERE APPLICABLE MUST REMAIN WITHIN DIMENSIONS

DRWG. NO. **SEE CHART** FILE NAME: S70182X1.DGN
 BY: PM
 CHECK'D BY: PM
 SCALE: 10:1

TITLE: CONNECTOR, VERT. MOUNT
 DUAL ROW TOP ENTRY
 .100 X .100 PC TAIL GRID

PART NO. MOLEX INCORPORATED U.S.A.
 L15LEJLL 60532

DRWG. NO. SDA-70182-****
 SHEET NO. 1 OF 2
 DATE 09/08/93

THIS DRAWING CONTAINS INFORMATION THAT IS PROPRIETARY TO MOLEX INC. AND SHOULD NOT BE USED WITHOUT WRITTEN PERMISSION.

