

# MAXIM

## MAX1837 Evaluation Kit

### General Description

The MAX1837 evaluation kit (EV kit) is a fully assembled and tested surface-mount circuit board that demonstrates the performance of the MAX1837 step-down DC-DC converter. The EV kit provides a +3.3V output from a +4.5V to +24.0V input and can deliver up to 250mA of load current. The EV kit circuit includes the MAX1837EUT33 DC-DC converter, which is preset to regulate the output voltage to +3.3V but can be reconfigured to output voltages in the +1.25V to +5.5V range. This EV kit can also be used to evaluate other preset voltage parts in the MAX1836/ MAX1837 family.

### Component List

DESIGNATION	QTY	DESCRIPTION
C1	1	10 $\mu$ F, 25V X5R ceramic capacitor (1812) Taiyo Yuden TMK432BJ106MM or TDK C4532X7R1E106KT
C2	1	150 $\mu$ F, 6.3V low-ESR capacitor (D3) Sanyo 6TPB150M
C3	0	Not installed (0805)
D1	1	0.5A, 30V Schottky diode (SOD-123) Nihon EP05Q03L
L1	1	22 $\mu$ H, 0.8A inductor Sumida CDRH5D18-220
R1, R2	0	Not installed, resistors (0805)
U1	1	MAX1837EUT33 (6-pin SOT23) Top mark: AANZ
JU1	1	3-pin header
None	1	Shunt
None	1	MAX1837 PC board
None	1	MAX1836/MAX1837 data sheet
None	1	MAX1837 EV kit data sheet

### Features

- ◆ Preset +3.3V Output Voltage
- ◆ 250mA Output Current
- ◆ +4.5V to +24.0V Input Voltage Range
- ◆ Adjustable Output Voltages (+1.25 to +5.5V)
- ◆ Low 12 $\mu$ A (typ) Quiescent Supply Current
- ◆ Surface-Mount Construction
- ◆ Fully Assembled and Tested

### Ordering Information

PART	TEMP. RANGE	IC PACKAGE
MAX1837EVKIT	0°C to +70°C	6 SOT23

### Component Suppliers

SUPPLIER	PHONE	FAX
Nihon	661-867-2555	661-867-2698
Sanyo	619-661-6835	619-661-1055
Sumida	847-956-0666	847-956-0702
Taiyo Yuden	408-573-4150	408-573-4159
TDK	847-803-6100	847-803-6296

**Note:** Please indicate that you are using the MAX1836/ MAX1837 when contacting these component suppliers.

### Quick Start

The MAX1837 EV kit is a fully assembled and tested surface-mount board. Follow the steps below for board operation. **Do not turn on the power supply until all connections are completed:**

- 1) Verify that a shunt is connected across pins 1 and 2 of jumper JU1.
- 2) Connect a voltmeter across the VOUT and GND pads to monitor output voltage.
- 3) Connect a +4.5V to +24.0V supply to the VIN pad. Connect the ground terminal to the GND pad.
- 4) Turn on the power supply and verify that the output voltage is +3.3V.

# MAX1837 Evaluation Kit

## Detailed Description

The MAX1837 EV kit provides a +3.3V output from a +4.5V to +24.0V input. The EV kit delivers up to 250mA and operates up to 100% duty cycle for low dropout voltage. The MAX1837 features a low-current (12 $\mu$ A typ) quiescent supply current as well as a low-current (3 $\mu$ A typ) shutdown mode.

The EV kit utilizes the MAX1837EUT33 IC, and the circuit regulates the output voltage to +3.3V without an external feedback network. The output can be adjusted for voltages in the +1.25V to +5.5V range by adding feedback resistors R1 and R2. For instructions on adjusting the output voltage, see the *Output Voltages* section. Other versions of the MAX1836/MAX1837, with different preset voltages and different maximum currents loads, can also be evaluated on this board. For instructions on how to evaluate other converters using this EV kit board, see the *Evaluating Other Converters* section.

### Output Voltages

The MAX1837 EV kit circuit is configured to regulate to the +3.3V output voltage by connecting the MAX1837EUT33 FB pin to ground. The output can be adjusted to a different voltage (+1.25V to +5.5V) by cutting open the PC board short at JU2, the short located at R2, and installing resistors R1 and R2. Refer to the *Output Voltage Selection* section of the MAX1836/MAX1837 data sheet for instructions on selecting R1 and R2. R2's resistance value should be between 10k $\Omega$  and 100k $\Omega$ . The output voltage ( $V_{OUT}$ ) is determined by the following equation:

$$V_{OUT} = V_{FB}((R1 / R2) + 1)$$

where  $V_{FB} = 1.25V$ .

### Enable/Disable

The EV kit contains a 3-pin jumper (JU1) that allows the user to enable or disable the MAX1837. See Table 1 for jumper configurations. The IC can also be shut down by removing the shunt on jumper JU1 and applying a CMOS logic level signal at pin 2 of the jumper.

## Evaluating Other Converters

The MAX1837 EV kit circuit board has a MAX1837EUT33 IC preinstalled. To evaluate other converters on the MAX1837 EV kit board, replace MAX1837EUT33 IC with an alternate part (Table 2). To evaluate the alternate part at its preset output voltage, verify that the FB pin is connected to ground (R2 shorted) and that the OUT pin is connected to VOUT (JU2 shorted). Refer to the *Inductor Selection and Output Capacitor* section of the MAX1836/MAX1837 data sheet to verify or resize the inductor and capacitor values for the application.

Table 1. Jumper JU1 Function Table

SHUNT LOCATION	$\overline{SHDN}$ PIN	EV KIT OPERATION
1 and 2	Connected to VIN	U1 enabled, $V_{OUT} = +3.3V$
2 and 3	Connected to GND	Shutdown mode, $V_{OUT} = 0$

Table 2. Alternate Step-Down Converters

PART NUMBER	PRESET OUTPUT VOLTAGE (V)	MAXIMUM OUTPUT CURRENT (mA)	TOP MARK
MAX1836EUT50	5.0	125	AANW
MAX1836EUT33	3.3	125	AANY
MAX1837EUT50	5.0	250	AANX
MAX1837EUT33	3.3	250	AANZ

# MAX1837 Evaluation Kit

Evaluates: MAX1836/MAX1837

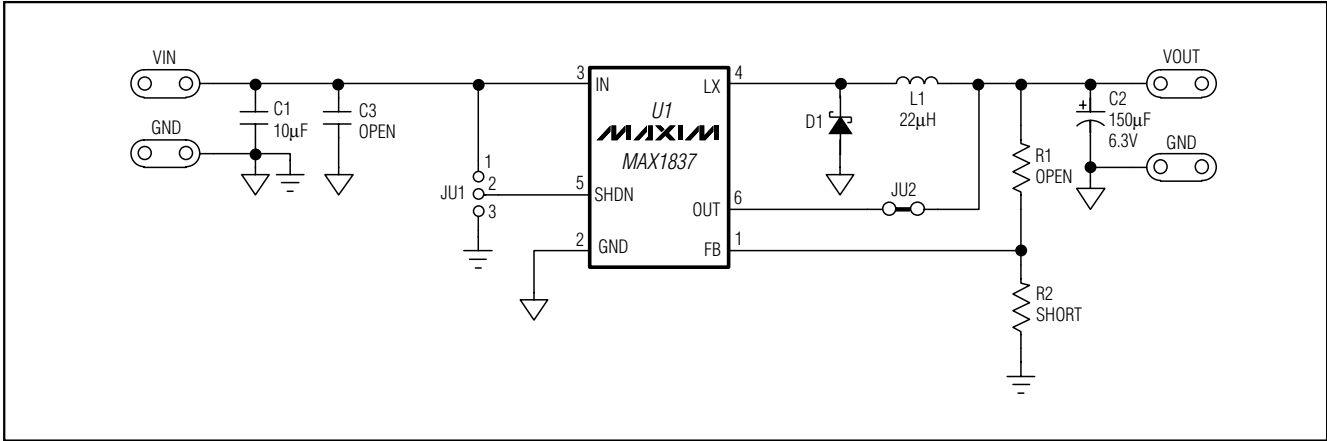

Figure 1. MAX1837 EV Kit Schematic

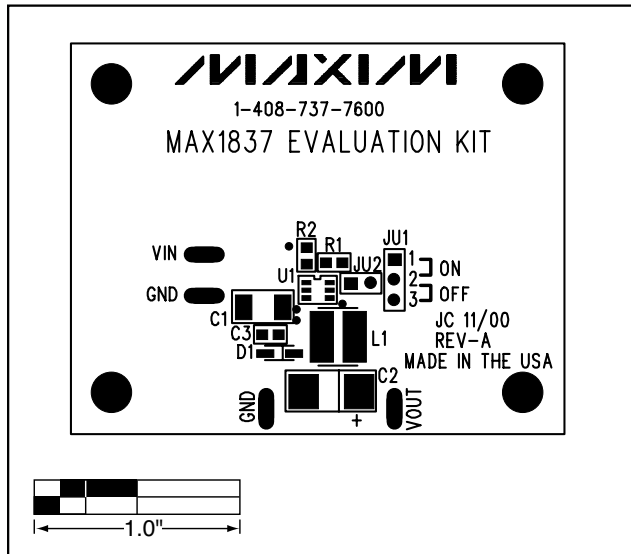

Figure 2. MAX1837 EV Kit Component Placement Guide—Component Side

# MAX1837 Evaluation Kit

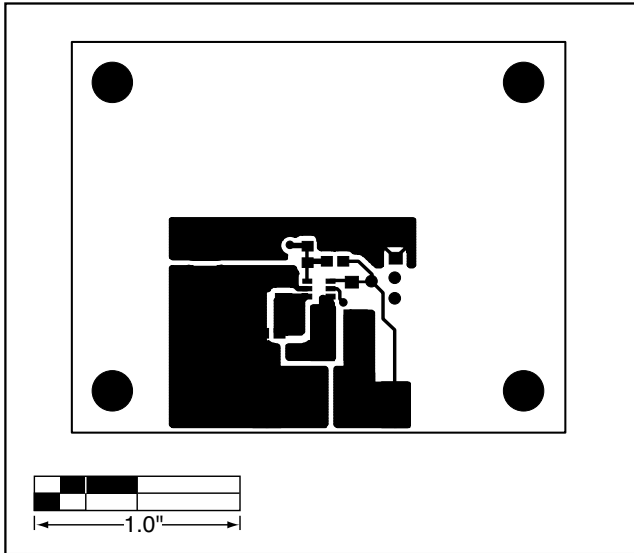

Figure 3. MAX1837 EV Kit PC Board Layout—Component Side

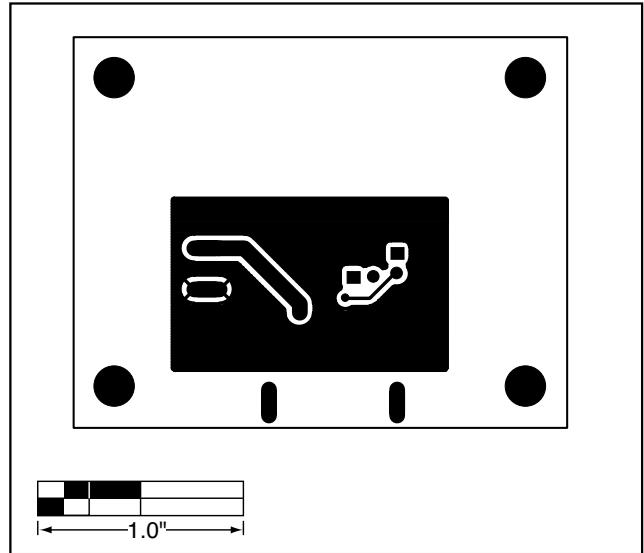

Figure 4. MAX1837 EV Kit PC Board Layout—Solder Side

Maxim cannot assume responsibility for use of any circuitry other than circuitry entirely embodied in a Maxim product. No circuit patent licenses are implied. Maxim reserves the right to change the circuitry and specifications without notice at any time.

4 \_\_\_\_\_ **Maxim Integrated Products, 120 San Gabriel Drive, Sunnyvale, CA 94086 408-737-7600**