

THIS DRAWING IS UNPUBLISHED. RELEASED FOR PUBLICATION 20
 © COPYRIGHT 20 BY - ALL RIGHTS RESERVED.

LOC AP DIST -

REVISIONS					
P	LTR	DESCRIPTION	DATE	DWN	APVD
E3		REDRAWN AND REVISED ECO 15-002215	25FEB2015	HC	WLS
E4		REVISED BY ECO 16-003728	11MAR2016	HC	WLS
E5		REV. BY ECO-18-012657	13AUG2018	HC	WLS

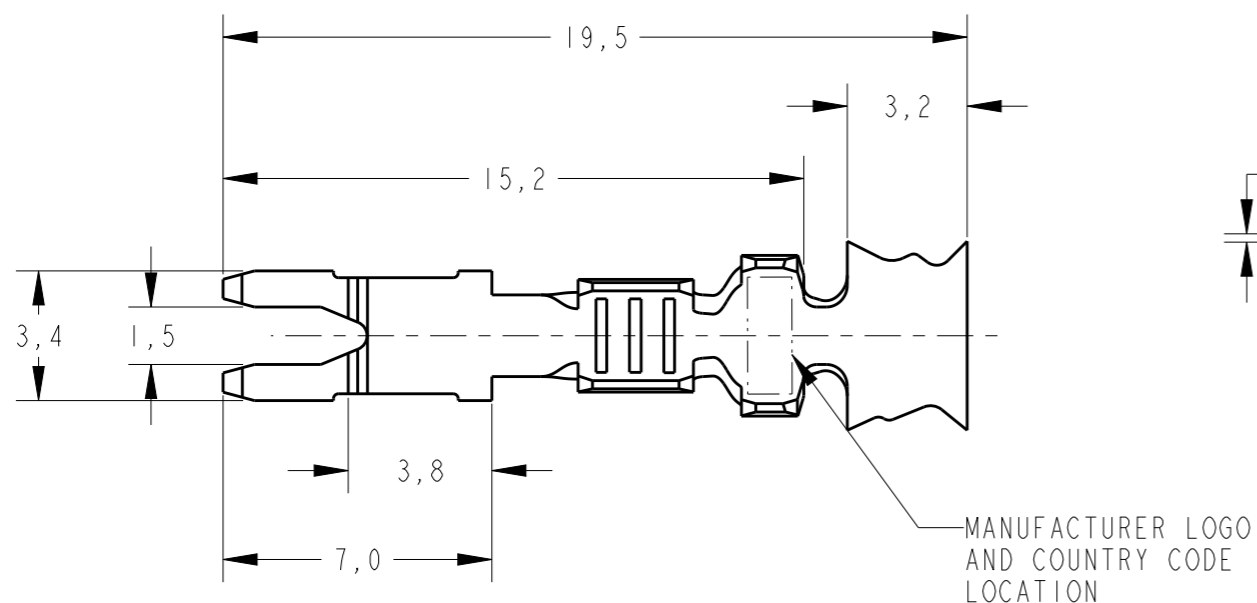

DETAIL Z
SCALE 10:1

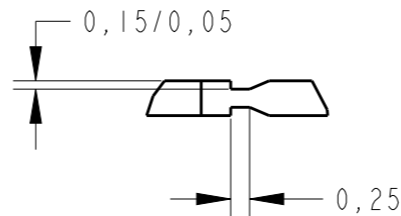

- 1 - SAME AS 881257-1 EXCEPT IT MUST BE BENT AT 90° DURING APPLICATION PROCESS (SEE DETAIL "X").
- 2 - SAME AS 881257-3 EXCEPT IT MUST BE BENT AT 90° DURING APPLICATION PROCESS (SEE DETAIL "X").

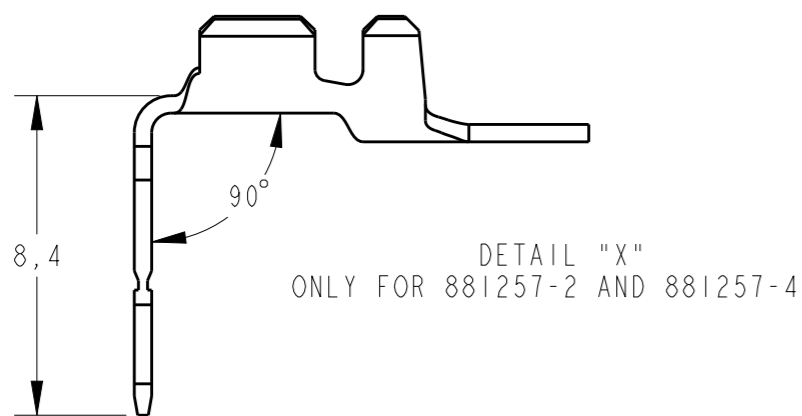
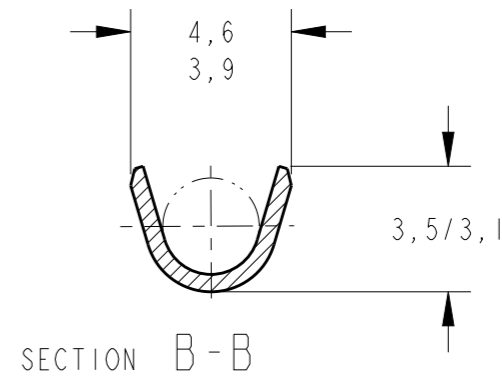
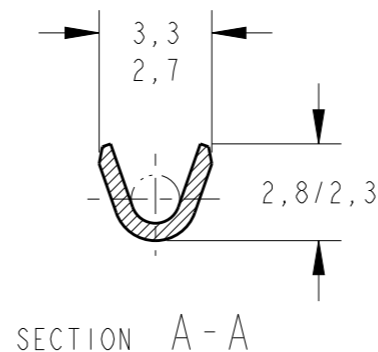
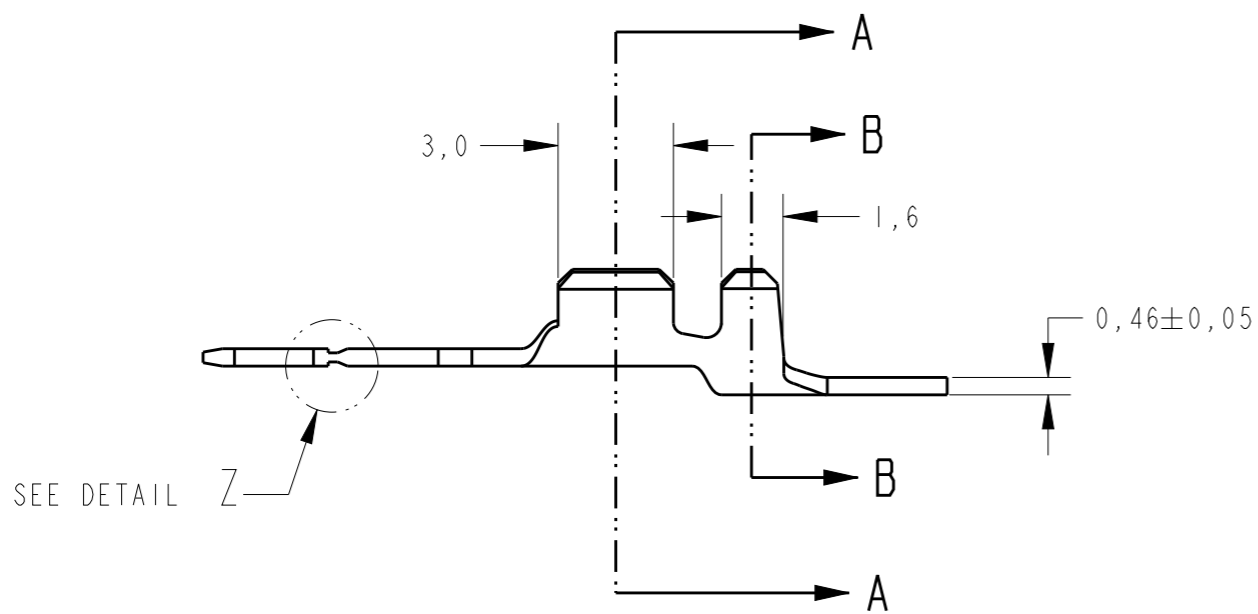

FINISH	MATERIAL	PART NUMBER
POST TIN PLATED OVER NICKEL	BRASS	881257-5
	BRASS	881257-4 ²
	BRASS	881257-3
PRE TIN PLATED	BRASS	881257-2 ¹
PRE TIN PLATED	BRASS	881257-1

INS. RANGE $\varnothing 1,5/2,5\text{mm.}$ WIRE RANGE 0,3/0,8mm²

THIS DRAWING IS A CONTROLLED DOCUMENT.

DWN 25FEB2015
H.C.CANTERI
CHK 26FEB2015
W.L.STEFANI



DIMENSIONS:	TOLERANCES UNLESS OTHERWISE SPECIFIED:
mm	
0 PLC	± -
1 PLC	± 0,3
2 PLC	±
3 PLC	±
4 PLC	±
ANGLES	± 1°

APVD -
PRODUCT SPEC -
APPLICATION SPEC -
WEIGHT -

NAME: MAG-MATE POKE-IN TAB
 SIZE: A3 CAGE CODE: 00779 DRAWING NO: 881257 RESTRICTED TO: -

MATERIAL: - FINISH: - Customer Drawing SCALE 5/11 SHEET 1 OF 1 REV E5