

# BG2B-Universal Dual IGBT Module Gate Driver Board

Free Sample Board with purchase of Gate Driver and DC-DC Converter

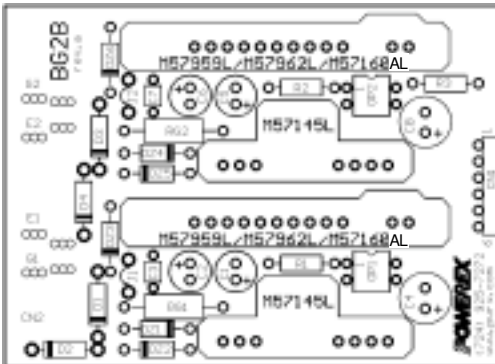

## Description

BG2B is a fully isolated gate drive circuit board designed for use with dual IGBT modules. When the board is populated, gate drive is supplied by M57159L, M57959L, M57962L or M57160AL hybrid gate drivers to provide efficient switching of modules rated up to 400A. The hybrid gate drivers also provide protection against unexpected short circuit conditions. Isolated control power for the driver is supplied by a pair of onboard M57145L-01 regulated DC/DC converters. The fault feedback signals are also optically isolated. See application note "Hybrid Circuits Simplify IGBT Module Gate Drive" at our web site [www.pwr.com](http://www.pwr.com).

## Features

- Up to 5A Output Current
- 2500VRMS Isolation
- Direct Mounting to IGBT
- +15V to -8.5V Output Voltage Swing
- Wide Input Voltage Range +12V to +18V

**Applications** Designed for use with the following Powerex Dual IGBT Modules

- CM75/100/150/200/300/400DU-12H/F
- CM50/75/100/150/200/300DU-24H/F

## Rapid Design - Component List

| Designation        | Description  | Value                    | Example Type            |
|--------------------|--|--------------------------|-------------------------|
| C1, C2, C5, C6     | Power supply decoupling capacitors. Low impedance long life type.              | 82µF<br>35V              | Panasonic FC EEUFC1V820 |
| C4, C8             | DC to DC converter input decoupling capacitor. Low impedance long life type    | 150µF<br>35V             | Panasonic FC EEUFC1V151 |
| C3, C7             | Optional - For adjustment of short circuit protection trip time.               | 0 to 10nF<br>50V         | muRata RPE Series       |
| R1, R2             | Current limit for fault opto   | 4.7K .25W                |                         |
| R3                 | Pull up for fault output   | 4.7K .25W                |                         |
| RG1, RG2           | Series gate resistor - See Powerex IGBT application notes                      | 3Ω to 100Ω<br>0.5W to 1W |                         |
| D1, D2, D3, D4     | Collector voltage detection diodes. Vrrm greater than IGBT Vces rating.        | 1A, 1000V<br>tr<100ns    | Motorola MUR1100E       |
| DZ1, DZ2, DZ4, DZ5 | Gate protection zeners   | 17V, 0.5W                | 1N5247                  |
| DZ3, DZ6           | Detect pin protection zener  | 30V, 0.5W                | 1N5256                  |
| OP1, OP2           | Opto for fault signal isolation  |                          | NEC PS2501              |
| CN1                | MTA100 6 position right angle header with locking ramp                         |                          | AMP 640457-6            |
| CN2                | 1/4" Ring Lug on 2" Wire   |                          | AMP 34151               |
| J1, J2             | Insert when using M57160AL with F-Series IGBT modules and omit D1-D4, DZ1- DZ6 |                          |                         |

## Schematic Diagram

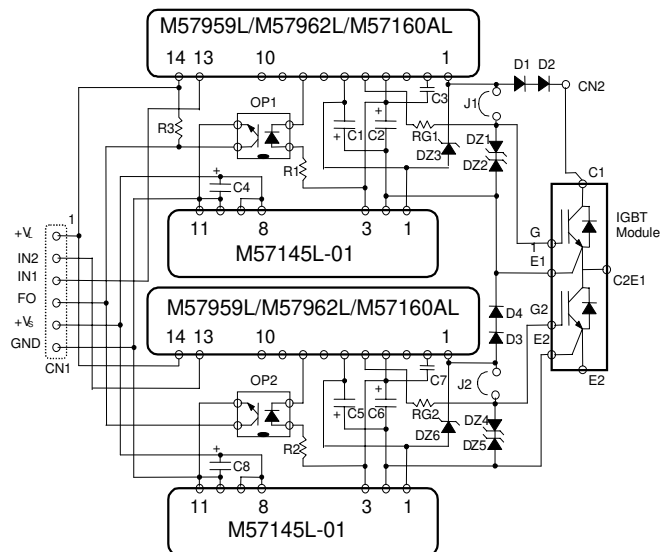

## Typical Interface Circuit

