

THIS DRAWING IS UNPUBLISHED. RELEASED FOR PUBLICATION
 © COPYRIGHT - By - ALL RIGHTS RESERVED.

LOC	DIST	REVISIONS			
P	LTR	DESCRIPTION	DATE	DWN	APVD
GP	00				
G		REVISED PER ECO-13-005685	10APR2013	CJV	SLB

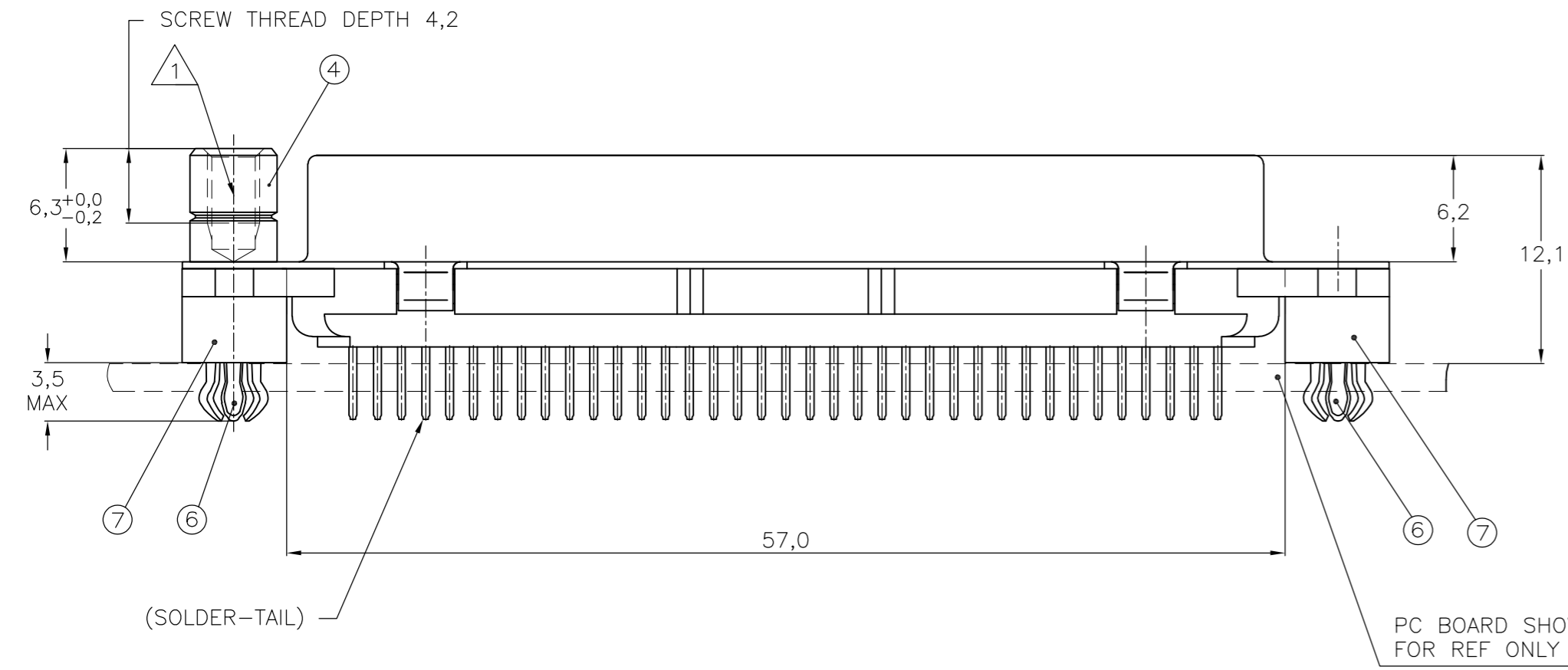
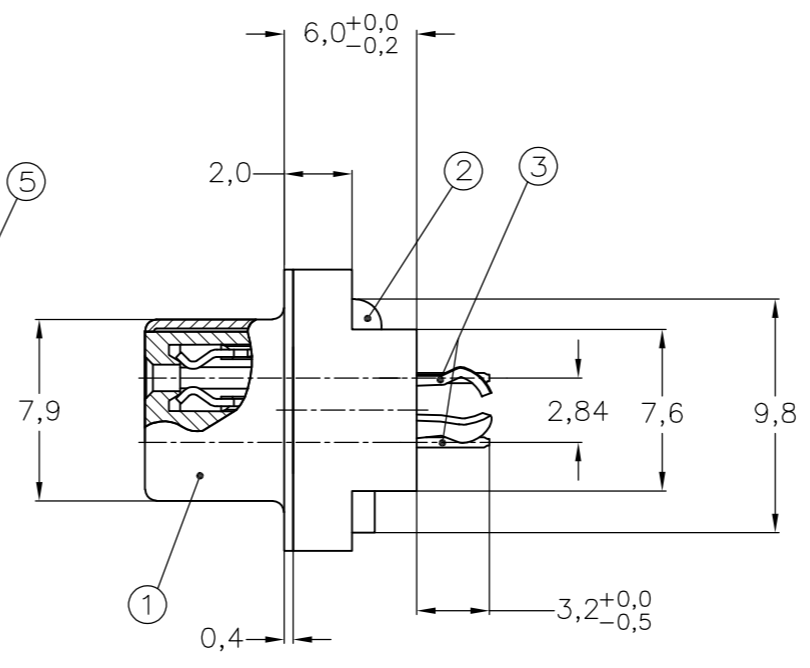
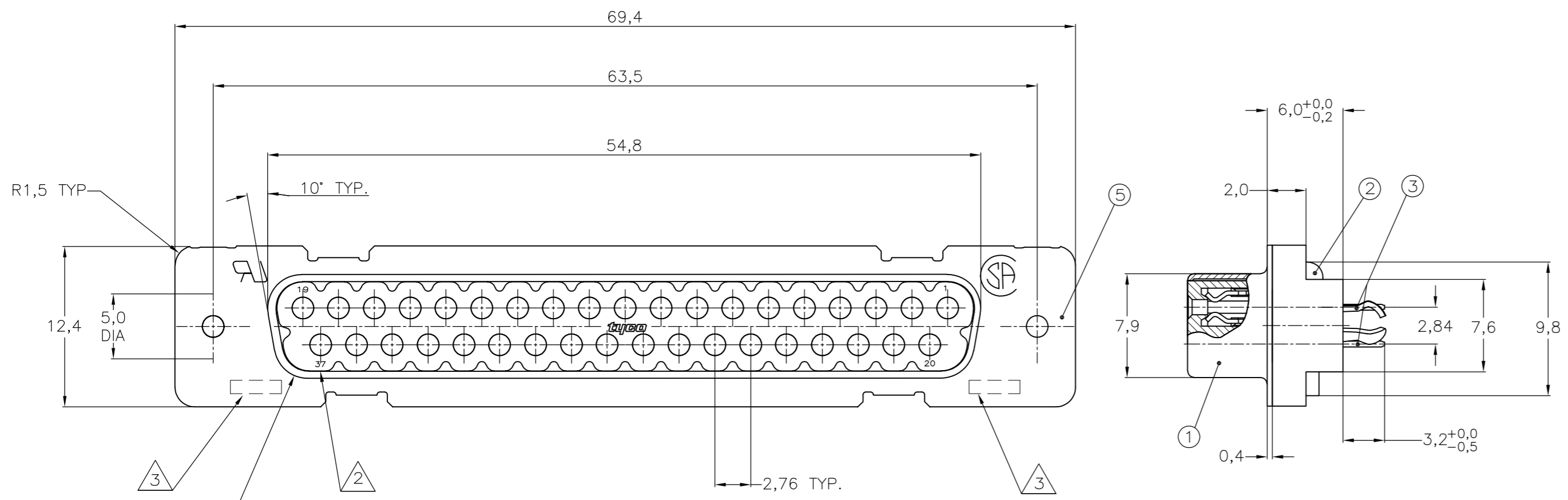

ITEM NO	DESCRIPTION OF ACCESSORY	1-338316-2	2-338316-2	3-338316-2	4-338316-2	5-338316-2	6-338316-2	7-338316-2	8-338316-2	9-338316-2
5	BUSHING WITH THROUGH-HOLE 3,1 DIA					2				
5	BUSHING WITH THREAD 4-40 UNC		2				2			
5	BUSHING WITH THREAD M3			2				2		
4	FEMALE SCREWLOCK WITH THREAD 4-40 UNC			2					2	
4	FEMALE SCREWLOCK WITH THREAD M3				2					2
6	BOARDLOCK	2	2	2	2					

- ① GROOVE INDICATES VERSION WITH 4-40 UNC INNER THREAD; WITHOUT GROOVE INDICATES VERSION WITH M3 INNER THREAD.
- ② CAVITY IDENTIFICATION AT FRONT SIDE ONLY.
- ③ PART NUMBER AND DATE CODE.
- 4. WHEN BOARDLOCKS ARE USED, CONNECTOR CAN BE USED FOR PCB THICKNESS OF 1,6 ONLY.
- 5. AIR AND CREEPAGE DISTANCES ACCORDING TO DIN 41652.
- 6. CONTACT FINISH: GOLD FLASH OVER PALLADIUM-NICKEL PLATE, OR GOLD PLATE ON THE MATING SURFACES, TIN PLATE ON THE SOLDER-TAILS, NICKEL UNDERPLATE ON THE ENTIRE CONTACT. MATING SURFACE FINISH MEETS PERFORMANCE LEVEL 2 PER DIN 41652.

ITEM NO/MATERIAL :

- ① SHELL = BRIGHT TIN PLATED STEEL
- ② HOUSING = GLASS FILLED POLYESTER, COLOR : BLACK
- ③ CONTACTS = PHOSPHOR BRONZE (PLATING : SEE TABLE ABOVE)
- ④ FEMALE SCREWLOCK = TIN PLATED STEEL (INNER THREAD 4-40 UNC OR M3)
- ⑤ BUSHING = TIN PLATED STEEL (INNER THREAD 4-40 UNC OR M3 OR 3,1 DIA THROUGH-HOLE)
- ⑥ BOARDLOCK = TIN PLATED PHOSPHOR BRONZE
- ⑦ STAND OFF = GLASS FILLED NYLON, UL95V-0 RATED COLOR : BLACK

RECOMMENDED P.C. BOARD HOLE-LAYOUT

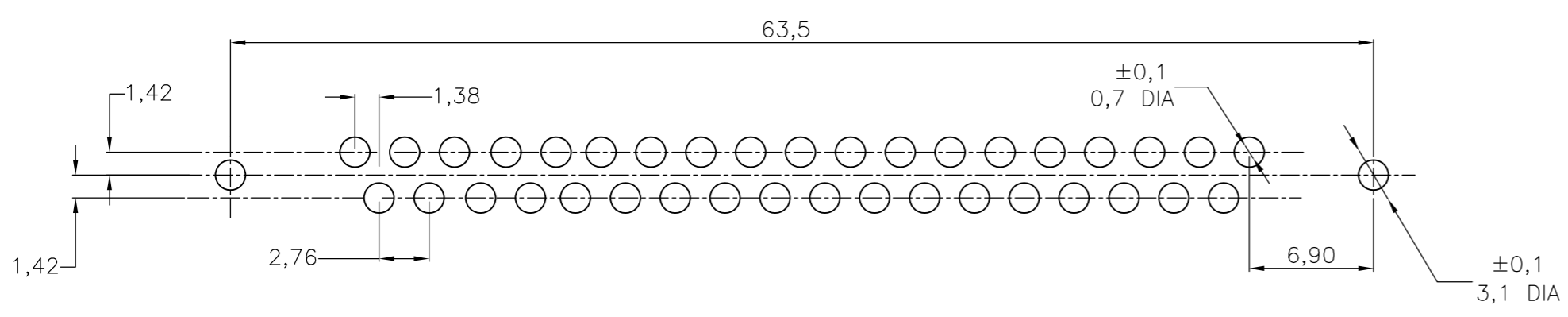

THIS DRAWING IS A CONTROLLED DOCUMENT. DIMENSIONING AND TOLERANCING PER ASME Y14.5M-2009		DWN J.V.LIEMPT 01JUL97	TE Connectivity			
TOLERANCES UNLESS OTHERWISE SPECIFIED:		CHK C.SOUISA 09SEP97				
DIMENSIONS: mm	0 PLC ± - 1 PLC ± 0.3 2 PLC ± 0.15 3 PLC ± - 4 PLC ± - ANGLES ± 2°	APVD E.LEIJTENS 09SEP97	NAME HDP-20 SIZE 4 VERTICAL+ RECEPTACLE HEADER; WITH SOLDER CONTACTS			
MATERIAL	FINISH	PRODUCT SPEC	SIZE A2	CAGE CODE 00779	DRAWING NO C=338316	RESTRICTED TO
CUSTOMER DRAWING		WEIGHT	SCALE NTS	SHEET 1 of 1	REV G	