

## 2 TO 18 GHz DOUBLE-BALANCED MIXER

### MODELS: DB0218LW2 AND DB0218LA1

#### FEATURES

- RF/LO coverage ..... 2 to 18 GHz
- IF operation ..... DC to 750 MHz
- LO power range ..... +7 to +13 dBm
- Conversion loss..... 6.5 dB typical
- Packaging..... Hermetically sealed



MITEQ's DB0218LW2 mixer is constructed of a balanced diode quad fed by microstrip RF and LO baluns and a DC-coupled IF structure. The construction, coupled with the hermetic packing, provides for high inherent reliability and performance over an extremely broad frequency range. This device performs as an up- or downconverter covering most EW bands, utility testing and breadboard applications.

#### ELECTRICAL SPECIFICATIONS

INPUT PARAMETERS	CONDITION	UNITS	MIN.	TYP.	MAX.
RF frequency range		GHz	2		18
RF VSWR (RF = -10 dBm, LO = +10 dBm)	2 to 18 GHz	Ratio		1.5:1	
LO frequency range		GHz	2		18
LO power range		dBm	+7	+10	+13
LO VSWR (LO = +10 dBm)	2 to 18 GHz	Ratio		1.5:1	
TRANSFER CHARACTERISTICS	CONDITION	UNITS	MIN.	TYP.	MAX.
Conversion loss (IF = 100 MHz, LO = +10 dBm)	2 to 18 GHz	dB		6.5	8.5
Single-sideband noise figure	2 to 18 GHz	dB			9
LO-to-RF isolation	2 to 18 GHz	dB	22	30	
LO-to-IF isolation	2 to 18 GHz	dB		20	
RF-to-IF isolation	2 to 18 GHz	dB		30	
Input power at 1 dB compression	LO = +10 dBm	dBm		+5	
Input two-tone third-order intercept point	LO = +10 dBm	dBm		+15	
OUTPUT PARAMETERS	CONDITION	UNITS	MIN.	TYP.	MAX.
IF frequency range	3 dB bandwidth	GHz	DC		0.75
IF VSWR (IF = -10 dBm, LO = +10 dBm)		Ratio		1.5:1	

# DB0218LW2/A1 TYPICAL TEST DATA

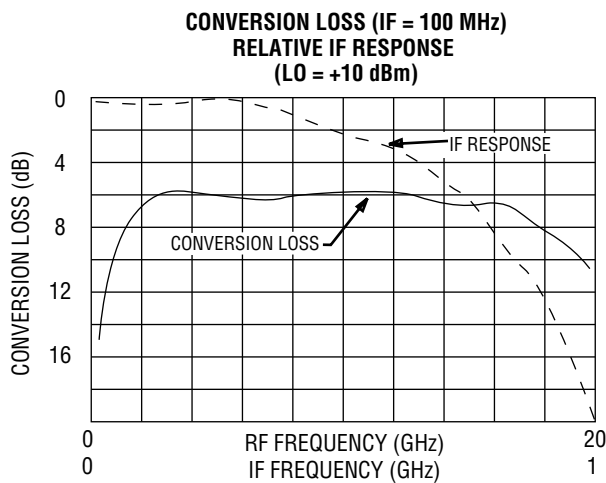
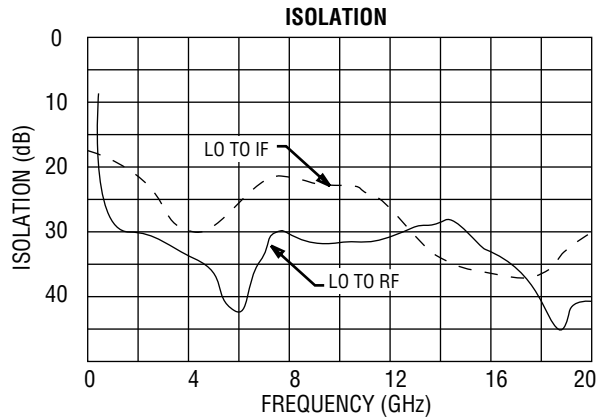
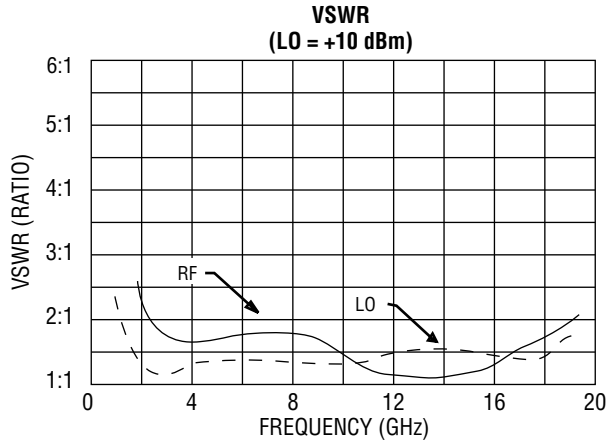

**SINGLE-TONE (m) RF x (n) LO RELATIVE SPUR LEVEL (dBc)**  
**TO REF (RF = -10 dBm, LO = +10 dBm)**

	5	> 85	> 85	> 85	> 85	> 85
RF HARMONIC (m)	4	75	75	80	85	80
	3	45	60	55	65	55
	2	43	49	50	50	60
	1	REF	30	11	33	20
		1	2	3	4	5
		LO HARMONIC (n)				

**MAXIMUM RATINGS**

Specification temperature ..... +25°C  
 Operating temperature ..... -54 to +85°C  
 Storage temperature ..... -65 to +125°C

**AVAILABLE OPTION**

Medium/high dynamic range options  
 M (LO = +13 to +17 dBm), (IP<sup>3</sup> = +18 dBm typ.)  
 H (LO = +17 to +20 dBm), (IP<sup>3</sup> = +22 dBm typ.)  
 Conversion loss = 9.5 dB max.

NOTE: Test data supplied at 25°C; conversion loss and LO-to-RF isolation.

## OUTLINE DRAWINGS

**W2 HOUSING**

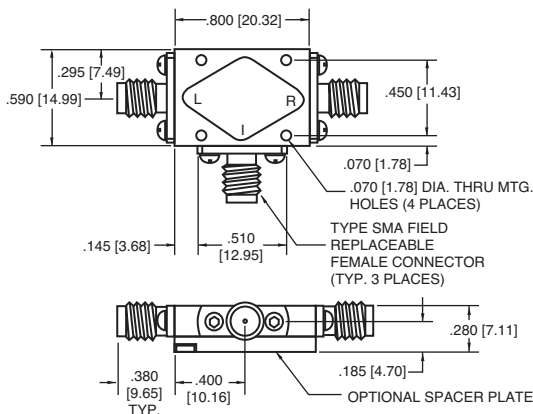

**A1 HOUSING**

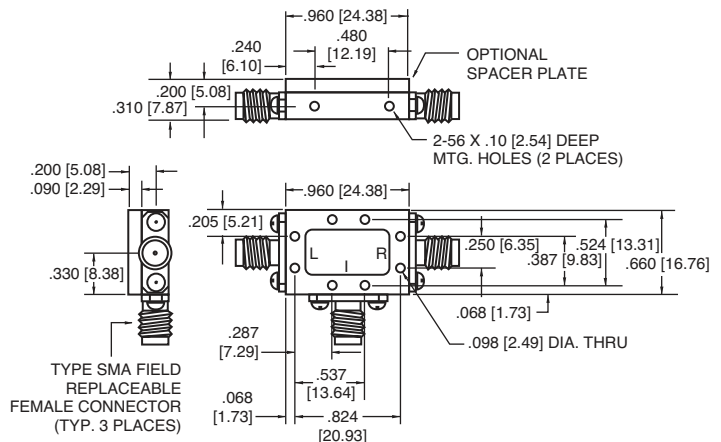

NOTE: All dimensions shown in brackets [ ] are in millimeters.

