



EVM-915-250
Data Guide

Wireless made simple[®]

Warning: Linx radio frequency ("RF") products may be used to control machinery or devices remotely, including machinery or devices that can cause death, bodily injuries, and/or property damage if improperly or inadvertently triggered, particularly in industrial settings or other applications implicating life-safety concerns. No Linx Technologies product is intended for use in any application without redundancies where the safety of life or property is at risk.

The customers and users of devices and machinery controlled with RF products must understand and must use all appropriate safety procedures in connection with the devices, including without limitation, using appropriate safety procedures to prevent inadvertent triggering by the user of the device and using appropriate security codes to prevent triggering of the remote controlled machine or device by users of other remote controllers.

Do not use this or any Linx product to trigger an action directly from the data line or RSSI lines without a protocol or encoder/decoder to validate the data. Without validation, any signal from another unrelated transmitter in the environment received by the module could inadvertently trigger the action.

All RF products are susceptible to RF interference that can prevent communication. RF products without frequency agility or hopping implemented are more subject to interference. This module does have a frequency hopping protocol built in, but the developer should still be aware of the risk of interference.

Do not use any Linx product over the limits in this data guide. Excessive voltage or extended operation at the maximum voltage could cause product failure. Exceeding the reflow temperature profile could cause product failure which is not immediately evident.

Do not make any physical or electrical modifications to any Linx product. This will void the warranty and regulatory and UL certifications and may cause product failure which is not immediately evident.

Table of Contents

- 1 [Description](#)
- 2 [Ordering Information](#)
- 3 [Electrical Specifications](#)
- 4 [Pin Assignments](#)
- 4 [Pin Descriptions](#)
- 5 [PCB Footprint](#)
- 6 [Board Layout Guidelines](#)
- 6 [Power Supply Requirements](#)
- 7 [Schematic Diagram](#)
- 7 [Helpful Application Notes from Linx](#)
- 8 [Usage Guidelines for FCC Compliance](#)
- 8 [Additional Testing Requirements](#)
- 9 [Information to the user](#)
- 10 [Product Labeling](#)
- 11 [Antenna Selection](#)
- 11 [Module Modification](#)

250 Series Transceiver Evaluation Module Data Guide



Figure 1: 250 Series Evaluation Module

Description

The EVM-915-250 features the 250 Series transceiver module in a modular approved solution. It is designed to greatly simplify implementation of the 250 Series module into a working design without the complications of FCC testing.

The 250 Series RF transceiver module is designed for reliable bi-directional transfer of digital data over distances of up to 4 miles (6.4km) line of sight. It implements a Frequency Hopping Spread Spectrum (FHSS) protocol along with networking and assured delivery features. The module automatically handles all radio functions resulting in a UART-to-antenna wireless link.

The module has a Universal Asynchronous Receiver Transmitter (UART) serial interface that can be directly connected to microcontrollers, RS-232 converters or USB adaptors. All configuration settings and data are accessed through the UART interface.

Ordering Information

Ordering Information		
Product Part No.	Description	Radiotronix Part No.
EVM-915-250-FCR	250 Series Evaluation Module, Right Angle RP-SMA Connector, FCC Approved	Wi.232FHSS-250-FCC-RA-R
EVM-915-250-FCS	250 Series Evaluation Module, Straight RP-SMA Connector, FCC Approved	Wi.232FHSS-250-FCC-ST-R
EVM-915-250-CFR	250 Series Evaluation Module, Right Angle RP-SMA Connector, Mexico CoFeTel Approved	Wi.232FHSS-250-FCC-CFTC-RA-R
EVM-915-250-CFS	250 Series Evaluation Module, Straight RP-SMA Connector, Mexico CoFeTel Approved	Wi.232FHSS-250-FCC-CFTC-ST-R

Figure 2: Ordering Information

Note: Please see the TRM-915-R250 data guide for complete information about the module, detailed specifications and configuration commands.

 **Warning:** This product incorporates numerous static-sensitive components. Always wear an ESD wrist strap and observe proper ESD handling procedures when working with this device. Failure to observe this precaution may result in module damage or failure.

Electrical Specifications

Electrical Specifications						
Parameter	Symbol	Min.	Typ.	Max.	Units	Notes
Power Supply						
Operating Voltage	V_{CC}	4		12	VDC	
Supply Current	I_{CC}					
Receive				25	mA	
Transmit, $P_o = 8\text{dBm}$				60	mA	
Transmit, $P_o = 23.5\text{dBm}$				200	mA	
RF Section						
Operating Frequency Band	F_c	902.2		927.8	MHz	
Number of Channels			32		Chan.	
Channel Spacing			750		kHz	
Max Data Rate		115.2			kbps	
Receiver Section						
Receiver Sensitivity						
9.6kbps			-105		dBm	
38.4kbps			-102		dBm	
153.6kbps			-100		dBm	
Transmitter Section						
Max Output Power	P_o		23.5	24	dBm	
Harmonic Emissions	P_H		-50		dBc	
Frequency Deviation	F_{DEV}		50		kHz	
Digital Interface						
Output						
Logic Low	V_{OL}	0		0.4	VDC	
Logic High	V_{OH}	2.5		V_{CC}	VDC	
Input						
Logic Low	V_{IL}	0		$0.3 \cdot V_{CC}$	VDC	
Logic High	V_{IH}	$0.7 \cdot V_{CC}$		V_{CC}	VDC	
Environmental						
Operating Temperature Range		-40		85	°C	

Figure 3: Electrical Specifications

Pin Assignments

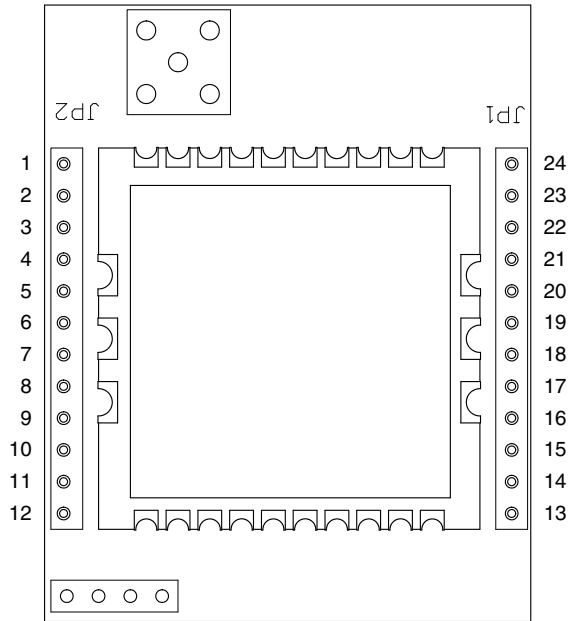

Figure 4: 25 Series EVM Module Pin Assignments (Top View)

Pin Descriptions

Pin Descriptions			
Pin Number	Name	I/O	Description
1	VCC	—	Supply Voltage
2	RXD	I	UART Receive Data Input. This is the input line for the configuration commands as well as data to be sent over the air.
3	TXD	O	UART Transmit Data Output. This is the output line for the configuration command responses as well as the data received over the air.
4	$\overline{\text{CTS}}$	O	UART Clear To Send, active low. This line indicates to the host microcontroller when the module is ready to accept data. When $\overline{\text{CTS}}$ is high, the module is busy. When $\overline{\text{CTS}}$ is low, the module is ready for data.
5	$\overline{\text{CMD}}$	I	Command Input. This line sets the serial data as either command data to configure the module or packet data to be sent over the air. Pull low for command data; pull high for packet data.

Pin Descriptions Continued

Pin Number	Name	I/O	Description
6, 7, 8, 9, 10, 15, 16, 17, 18	NC	—	No Electrical Connection. Do not connect any traces to these lines.
11, 12, 13, 14, 23, 24	GND	—	Ground
19	EX	O	Exception Output. A mask can be set to take this line high when an exception occurs. The line is lowered when the exception register is read (regEXCEPTION)
20	RSSI	O	This line outputs an analog voltage that is proportional to the strength of the incoming signal.
21	$\overline{\text{CMD_RSP}}$	O	Command Response. This line is low when the data on the TXD line is a response to a command and not data received over the air.
22	BE	O	Buffer Empty. This line goes high when the UART input buffer is empty, indicating that all data has been transmitted.

Figure 5: 25 Series EVM Module Pin Descriptions

PCB Footprint

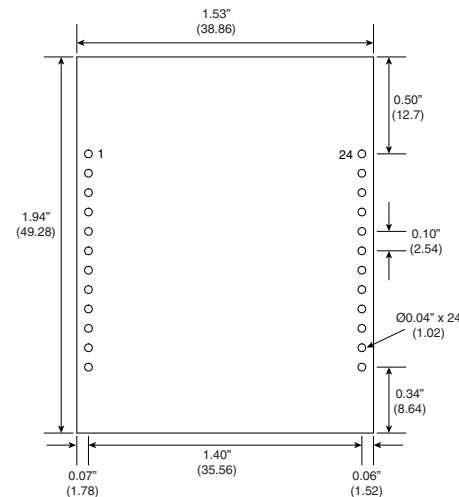

Figure 6: 25 Series EVM Module PCB Footprint

Board Layout Guidelines

The module's design makes integration straightforward; however, it is still critical to exercise care in PCB layout. Failure to observe good layout techniques can result in a significant degradation of the module's performance. Grounding, filtering, decoupling, routing and PCB stack-up are all important considerations for any RF design. Some basic design guidelines are provided here.

The module should, as much as reasonably possible, be isolated from other components on your PCB, especially high-frequency circuitry such as crystal oscillators, switching power supplies, and high-speed bus lines.

When possible, separate RF and digital circuits into different PCB regions.

Make sure internal wiring is routed away from the module and antenna and is secured to prevent displacement.

Bypass caps should be low ESR ceramic types and located directly adjacent to the pin they are serving.

In some instances, a designer may wish to encapsulate or "pot" the product. Since such compounds can considerably impact RF performance and the ability to rework or service the product, it is the responsibility of the designer to evaluate and qualify the impact and suitability of such materials.

Power Supply Requirements

The transceiver incorporates a precision low-dropout regulator which allows operation over a wide input voltage range. Despite this regulator, it is still important to provide a supply that is free of noise. Power supply noise can significantly affect the module's performance, so providing a clean power supply for the module should be a high priority during design.

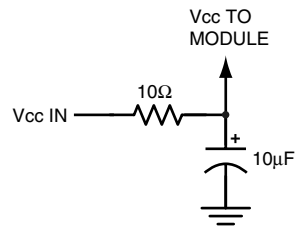

Figure 7: Supply Filter

A 10Ω resistor in series with the supply followed by a 10μF tantalum capacitor from V_{cc} to ground helps in cases where the quality of supply power is poor (Figure 7). This filter should be placed close to the module's supply lines. These values may need to be adjusted depending on the noise present on the supply line.

Schematic Diagram

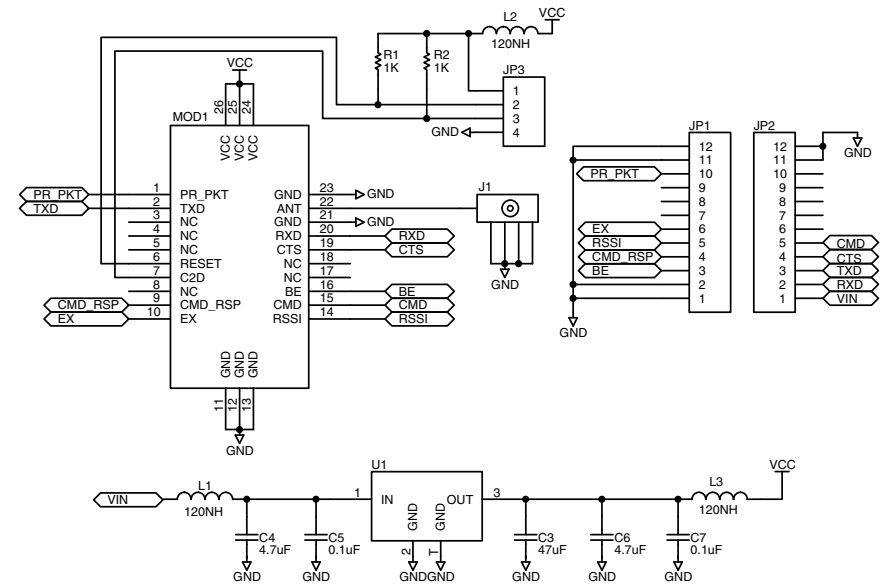

Figure 8: 25 Series EVM Module Schematic

Helpful Application Notes from Linx

It is not the intention of this manual to address in depth many of the issues that should be considered to ensure that the modules function correctly and deliver the maximum possible performance. As you proceed with your design, you may wish to obtain one or more of the following application notes which address in depth key areas of RF design and application of Linx products. These application notes are available online at www.linxtechnologies.com or by contacting Linx.

Helpful Application Note Titles	
Note Number	Note Title
AN-00100	RF 101: Information for the RF Challenged
AN-00126	Considerations for Operation Within the 902–928MHz Band
AN-00130	Modulation Techniques for Low-Cost RF Data Links
AN-00140	The FCC Road: Part 15 from Concept to Approval
AN-00160	Considerations for Sending Data Over a Wireless Link
AN-00500	Antennas: Design, Application, Performance
AN-00501	Understanding Antenna Specifications and Operation

Figure 9: Helpful Application Notes

Usage Guidelines for FCC Compliance

The 250 Series module is provided with an FCC, Industry Canada and Mexico COFETEL Modular Certification. This certification shows that the module meets the requirements of FCC Part 15 and Industry Canada license-exempt RSS standards for an intentional radiator. The integrator does not need to conduct any further testing under these rules provided that the following guidelines are met:

- An approved antenna must be directly coupled to the module's RP-SMA connector through an approved coaxial extension cable.
- Alternate antennas can be used, but may require the integrator to perform certification testing.
- The module must not be modified in any way. Coupling of external circuitry must not bypass the provided connectors.
- End product must be externally labeled with "Contains FCC ID: Q7V-3F090009X / IC: 5589A-3F090009".
- The end product's user's manual must contain an FCC statement equivalent to that listed on page 9 of this data guide.
- The antenna used for this transceiver must not be co-located or operating in conjunction with any other antenna or transmitter.
- The integrator must not provide any information to the end-user on how to install or remove the module from the end-product.

Note: The integrator is required to perform unintentional radiator testing on the final product per FCC sections 15.107 and 15.109 and IC RSS-GEN.

Any changes or modifications not expressly approved by Linx Technologies could void the user's authority to operate the equipment.

Additional Testing Requirements

The modules have been tested for compliance as an intentional radiator, but the integrator is required to perform unintentional radiator testing on the final product per FCC sections 15.107 and 15.109 and Industry Canada license-exempt RSS standards. Additional product-specific testing might be required. Please contact the FCC, Industry Canada or ANATEL regarding regulatory requirements for the application. Ultimately it is the integrator's responsibility to show that their product complies with the regulations applicable to their product.

Information to the user

The following information must be included in the product's user manual.

FCC / IC NOTICES

This product contains FCC ID: Q7V-3F090009X / IC: 5589A-3F090009

This device complies with Part 15 of the FCC rules and Industry Canada license-exempt RSS standards. Operation of this device is subject to the following two conditions:

1. This device may not cause harmful interference, and
2. this device must accept any interference received, including interference that may cause undesired operation.

This equipment has been tested and found to comply with the limits for a Class B digital device, pursuant to Part 15 of the FCC Rules. These limits are designed to provide reasonable protection against harmful interference in a residential installation. This equipment generates, uses and can radiate radio frequency energy and, if not installed and used in accordance with the instructions, may cause harmful interference to radio communications. However, there is no guarantee that interference will not occur in a particular installation. If this equipment does cause harmful interference to radio or television reception, which can be determined by turning the equipment off and on, the user is encouraged to try to correct the interference by one or more of the following measures:

- Reorient or relocate the receiving antenna.
- Increase the separation between the equipment and receiver.
- Connect the equipment into an outlet on a circuit different from that to which the receiver is connected.
- Consult the dealer or an experienced radio/TV technician for help.

Any modifications could void the user's authority to operate the equipment.

Le présent appareil est conforme aux CNR d'Industrie Canada applicables aux appareils radio exempts de licence. L'exploitation est autorisée aux deux conditions suivantes:

1. l'appareil ne doit pas produire de brouillage, et
2. l'utilisateur de l'appareil doit accepter tout brouillage radioélectrique subi, même si le brouillage est susceptible d'en compromettre le fonctionnement.

Product Labeling

The end product must be labeled to meet the FCC product label requirements. It must have the below or similar text:

Contains FCC ID: Q7V-3F090009X / IC: 5589A-3F090009

The Brazil version must contain:

Anatel: 0946-08-4266

The label must be permanently affixed to the product and readily visible to the user. “Permanently affixed” means that the label is etched, engraved, stamped, silkscreened, indelibly printed, or otherwise permanently marked on a permanently attached part of the equipment or on a nameplate of metal, plastic, or other material fastened to the equipment by welding, riveting, or a permanent adhesive. The label must be designed to last the expected lifetime of the equipment in the environment in which the equipment may be operated and must not be readily detachable.

Antenna Selection

Under FCC, Industry Canada, COFETEL and ANATEL regulations, this radio transmitter may only operate using an antenna of a type and maximum (or lesser) gain approved for the transmitter by the FCC, Industry Canada and ANATEL. To reduce potential radio interference to other users, the antenna type and its gain should be so chosen that the equivalent isotropically radiated power (e.i.r.p.) is not more than that necessary for successful communication.

The EVM-915-250-FCx radio transmitter has been approved by the FCC and Industry Canada, the EVM-915-250-CFx and the Wi.232FHSS-250B-xx-R has been approved by ANATEL to operate with the antenna types listed in Figure 10 with the maximum permissible gain and required antenna impedance for each antenna type indicated. Antenna types not included in this list, having a gain greater than the maximum gain indicated for that type, are strictly prohibited for use with this device.

Antennas			
Linx Part Number	Type	Gain	Impedance
ANT-916-CW-QW	¼ Wave Whip	1.84dBi	50Ω
ANT-916-CW-HW	½ Wave Dipole Helical	1.83dBi	50Ω

Figure 10: Antenna Selection

An approved antenna must be directly attached to the module’s reverse-polarity SMA connector in the final application to inherit the modular certifications.

Module Modification

The module must not be physically altered in any way. If any connections are made to the modules that bypass the module pins, socket or antenna connector, none of the modular certifications can be inherited.



Linx Technologies
159 Ort Lane
Merlin, OR, US 97532

Phone: +1 541 471 6256
Fax: +1 541 471 6251

www.linxtechnologies.com

Disclaimer

Linx Technologies is continually striving to improve the quality and function of its products. For this reason, we reserve the right to make changes to our products without notice. The information contained in this Data Guide is believed to be accurate as of the time of publication. Specifications are based on representative lot samples. Values may vary from lot-to-lot and are not guaranteed. "Typical" parameters can and do vary over lots and application. Linx Technologies makes no guarantee, warranty, or representation regarding the suitability of any product for use in any specific application. It is the customer's responsibility to verify the suitability of the part for the intended application. **NO LINX PRODUCT IS INTENDED FOR USE IN ANY APPLICATION WHERE THE SAFETY OF LIFE OR PROPERTY IS AT RISK.**

Linx Technologies **DISCLAIMS ALL WARRANTIES OF MERCHANTABILITY AND FITNESS FOR A PARTICULAR PURPOSE. IN NO EVENT SHALL LINX TECHNOLOGIES BE LIABLE FOR ANY OF CUSTOMER'S INCIDENTAL OR CONSEQUENTIAL DAMAGES ARISING IN ANY WAY FROM ANY DEFECTIVE OR NON-CONFORMING PRODUCTS OR FOR ANY OTHER BREACH OF CONTRACT BY LINX TECHNOLOGIES.** The limitations on Linx Technologies' liability are applicable to any and all claims or theories of recovery asserted by Customer, including, without limitation, breach of contract, breach of warranty, strict liability, or negligence. Customer assumes all liability (including, without limitation, liability for injury to person or property, economic loss, or business interruption) for all claims, including claims from third parties, arising from the use of the Products. The Customer will indemnify, defend, protect, and hold harmless Linx Technologies and its officers, employees, subsidiaries, affiliates, distributors, and representatives from and against all claims, damages, actions, suits, proceedings, demands, assessments, adjustments, costs, and expenses incurred by Linx Technologies as a result of or arising from any Products sold by Linx Technologies to Customer. Under no conditions will Linx Technologies be responsible for losses arising from the use or failure of the device in any application, other than the repair, replacement, or refund limited to the original product purchase price. Devices described in this publication may contain proprietary, patented, or copyrighted techniques, components, or materials. Under no circumstances shall any user be conveyed any license or right to the use or ownership of such items.

©2015 Linx Technologies. All rights reserved.

The stylized Linx logo, Wireless Made Simple, WISE, CipherLinx and the stylized CL logo are trademarks of Linx Technologies.