

Tous droits strictement reserves. Reproduction ou communication a des tiers interdite sous quelque forme que ce soit sans autorisation écrite du propriétaire. Propriete de c FCI. Droits de reproduction FCI.

All rights strictly reserved. Reproduction or issue to third parties in any form whatever is not permitted without written authority from the proprietor. Property of FCI. Copyright FCI.

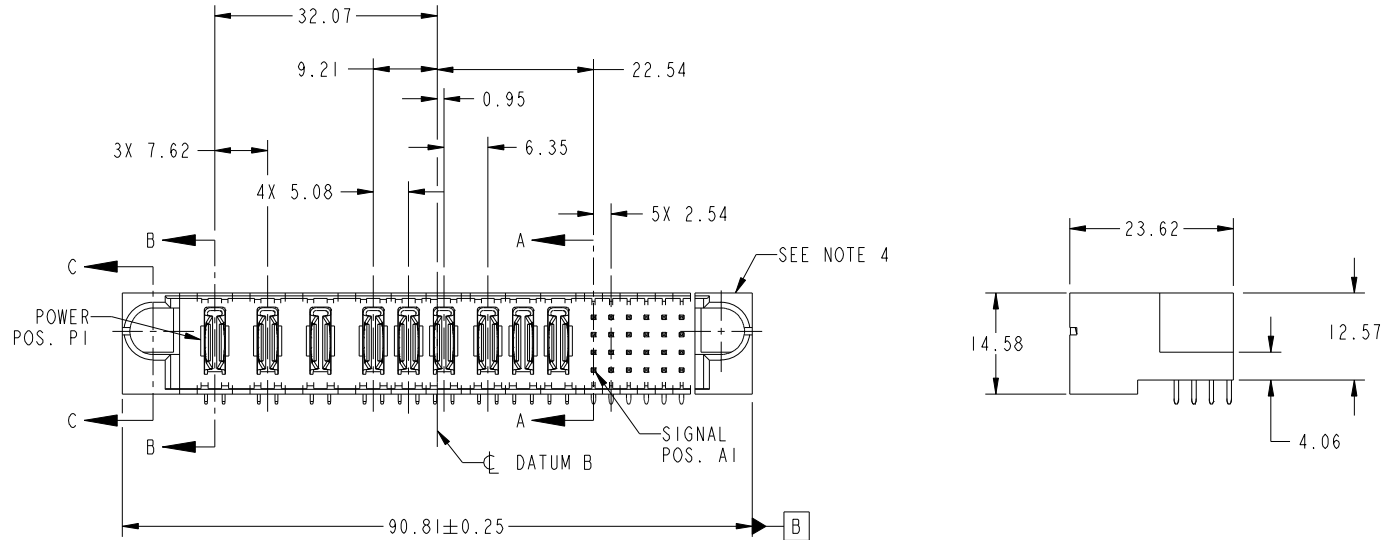

PRODUCT NO.	ROWS	POWER									SIGNAL							
		E1	P1	P2	P3	P4	P5	P6	P7	P8	P9	1	2	3	4	5	6	E2
51939-546... NOTE: 3	D C B A		PA	PA	PA	PA	PA	PA	PA	PA	PA	U	H	U	U	H		
			T	T	T	T	T	T	T	T	T	G	G					
			S	S	S	S	S	S	S	S	S	F	F	F	F			
			R	R	R	R	R	R	R	R								



CODE	DIM "M" MATING LENGTH	CONTACT TYPE
E	[5.59]	SIGNAL
F	[5.59]	SIGNAL
G	[5.59]	SIGNAL
H	[5.59]	SIGNAL
R	[6.86]	SIGNAL
S	[6.86]	SIGNAL
T	[6.86]	SIGNAL
U	[6.86]	SIGNAL
PA	[N/A]	POWER

mat'l code				SEE NOTE		tolerances unless otherwise specified		CUSTOMER		FCI	
ltr	ecn no.	dr	date	linear	0.X ±0.5	projection		COPY		www.fciconnect.com	
A	DG10-0240	SM	06/28/10	angles	0.XX ±0.25	MIM		title		9P + 24S	
					0.XXX ±0.10	scale		product family		PwrBlade	
				dr	0° ±2°	1:1		size		code	
				enr	Shower Ma 06/28/10			dwg no		213	
				chr	Shower Ma 06/28/10			A		51939-546	
				appd	PM ZHENG 06/28/10			sheet		1 of 4	
					JOSEPH HSIA 06/28/10			cage code		22526	
sheet index	revision sheet	A 1	A 2	A 3	A 4						

Pro/E

cage code 22526

Tous droits strictement reserves. Reproduction ou communication a des tiers interdite sous quelque forme que ce soit sans autorisation écrite du propriétaire. Propriete de c FCI. Droits de reproduction FCI.



All rights strictly reserved. Reproduction or issue to third parties in any form whatever is not permitted without written authority from the proprietor. Property of FCI. Copyright FCI.

PRODUCT NUMBER  
51939-546--  
NOTE: 3

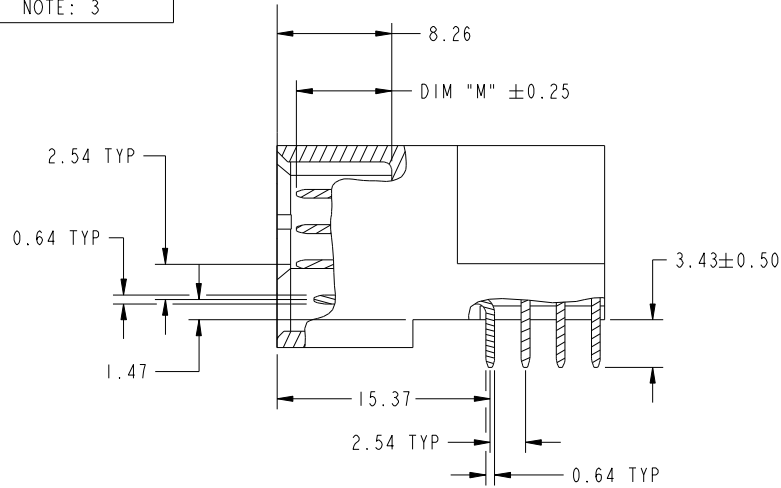

BROKEN-OUT SECTION A-A  
SCALE 2:1

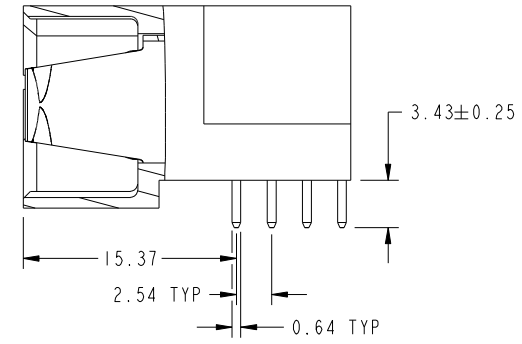

BROKEN-OUT SECTION B-B  
SCALE 2:1

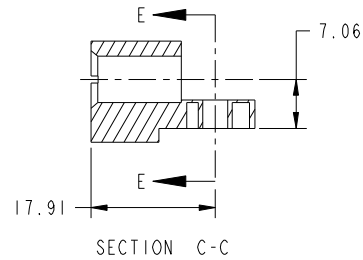

SECTION C-C

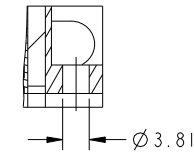

PARTIAL SECTION E-E

mat'l code		SEE NOTE		tolerances unless otherwise specified		CUSTOMER		FCI		www.fciconnect.com	
ltr	ecn no.	dr	date	linear	0.X ±0.5	projection	COPY	title		9P + 24S	
A					0.XX ±0.25			RIGHT ANGLE SOLDER HEADER		code	
				angles	0.XXX ±0.10			product family	PwrBlade	213	
				dr	0° ±2°	scale	1:1	size	A	product family	PwrBlade
				enr	Shower Ma 06/28/10			dwg no	51939-546	sheet	2 of 4
				chr	PM ZHENG 06/28/10						
				appd	JOSEPH HSIA 06/28/10						
sheet index	revision sheet										

cage code 22526

Pro/E

Tous droits strictement reserves. Reproduction ou communication a des tiers interdite sous quelque forme que ce soit sans autorisation écrite du propriétaire. Propriete de c FCI. Droits de reproduction FCI.



All rights strictly reserved. Reproduction or issue to third parties in any form whatever is not permitted without written authority from the proprietor. Property of FCI. Copyright FCI.

PRODUCT NUMBER  
51939-546--  
NOTE: 3

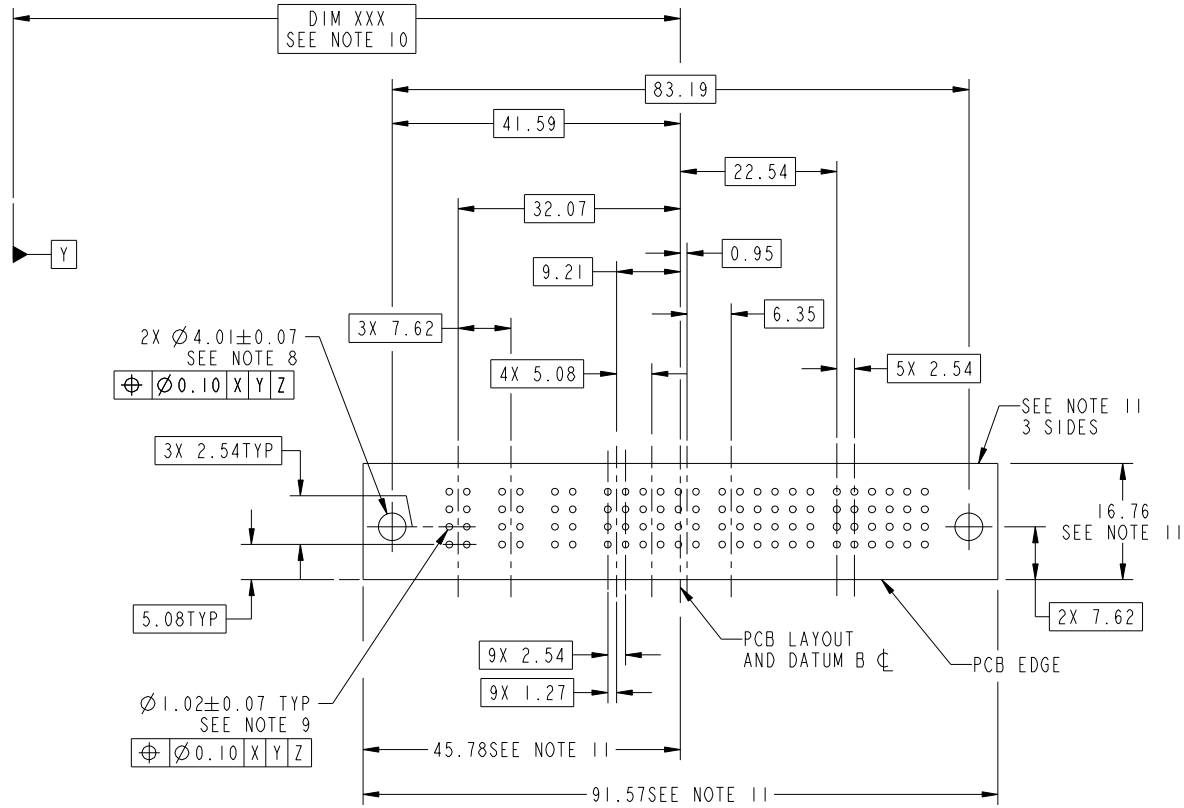

RECOMMENDED PCB LAYOUT

mat'l code		SEE NOTE		tolerances unless otherwise specified		CUSTOMER		www.fciconnect.com	
ltr	ecn no.	dr	date	linear	0.X ± 0.5	COPY		title	
A					0.XX ± 0.25	projection		9P + 24S	
				angles	0.XXX ± 0.10			RIGHT ANGLE SOLDER HEADER	
				dr	0° + 2°			product family	PwrBlade
				enrg	Shower Ma 06/28/10	scale		size	code
				chr	Shower Ma 06/28/10	1:1		dwg no	213
				appd	PM ZHENG 06/28/10			51939-546	sheet
					JOSEPH HSIA 06/28/10			A	3 of 4
sheet index	revision sheet								

cage code 22526

Pro/E

Tous droits strictement reserves. Reproduction ou communication a des tiers interdite sous quelque forme que ce soit sans autorisation ecrite du proprietaire. Propriete de c FCI. Droits de reproduction FCI.



All rights strictly reserved. Reproduction or issue to third parties in any form whatever is not permitted without written authority from the proprietor. Property of FCI. Copyright FCI.

PRODUCT NUMBER
51939-546_- NOTE: 3

NOTES:

1. DIMENSIONS AND TOLERANCES ARE IN ACCORDANCE WITH ASME Y14.5M, 1994 UNLESS OTHERWISE SPECIFIED.

CONNECTOR NOTES:

- 2. HOUSING MATERIAL: UL 94 V-0 GLASS FILLED HIGH-TEMP THERMOPLASTIC  
POWER CONTACT MATERIAL: COPPER ALLOY  
SIGNAL PIN MATERIAL: COPPER ALLOY
- 3. PLATING:  
SEE ITEM 1 & 2 IN PRINT 10064183 FOR PLATING SPEC OF 51939-546; 51939-546LF
- 4. MANUFACTURER'S NAME, P/N, AND DATE CODE TO APPEAR ON THIS SURFACE.
- 5. PRODUCT SPECIFICATION GS-12-149.  
APPLICATION SPECIFICATION BUS-20-067.
- 6. PACKAGED IN TRAYS.

PCB NOTES:

- 7. ALL HOLE DIAMETERS ARE FINISHED HOLE SIZE.
- 8. MOUNTING HOLES, WHERE APPLICABLE, ARE UNPLATED.
- 9.  $\varnothing 1.151 \pm 0.025$  DRILLED HOLES PLATED WITH 0.008 MIN SnPb OR Sn OVER 0.03 TO 0.08 Cu PLATING TO ACHIEVE  $\varnothing 1.02 \pm .07$  HOLE.
- 10. "DIM XXX" TO BE DETERMINED BY THE CUSTOMER.
- 11. CONNECTOR KEEP-OUT ZONE.

mat'l code		SEE NOTE		tolerances unless otherwise specified		CUSTOMER		www.fciconnect.com	
ltr	ecr no.	dr	date	linear	0.X ± 0.5	COPY		title	
A					0.XX ± 0.25	projection		9P + 24S	
				angles	0.XXX ± 0.10			RIGHT ANGLE SOLDER HEADER	
				dr	Shower Ma 06/28/10	MIM		product family PwrBlade code	
				enr	Shower Ma 06/28/10			size 213	
				chr	PM ZHENG 06/28/10	scale		dwg no 51939-546 sheet	
				appd	JOSEPH HSIA 06/28/10	1:1		4 of 4	
sheet index	revision sheet								

cage code 22526

Pro/E