

VR xx 51x 2 xxxx G

- 02 2 Poles
- 03 3 Poles
- ... ..
- 24 24 Poles

- Color
- 0 Black (RAL9005)
  - 2 Red (RAL3001/D)
  - 3 Orange(RAL2011/P)
  - 4 Yellow(RAL1018/A)
  - 5 Green(RAL6018/T)
  - 6 Blue (RAL5015/A)
  - 8 Grey(RAL7035/D)
  - 9 White(RAL1102)
  - C Green(RAL6018/U)

G RoHS compliant (lead<4%) In copper Alloy

0000 Standard @ Logo  
000A Standard ANY Logo  
Any special item by customer request, please contact sales department.

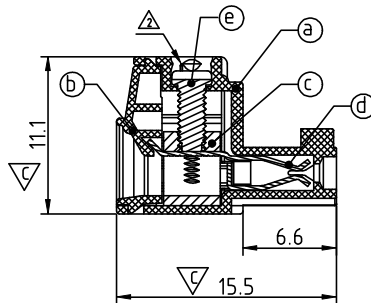
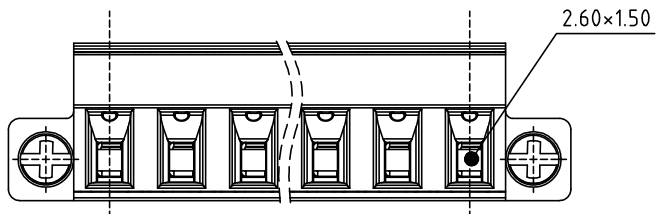

SECTION A-A

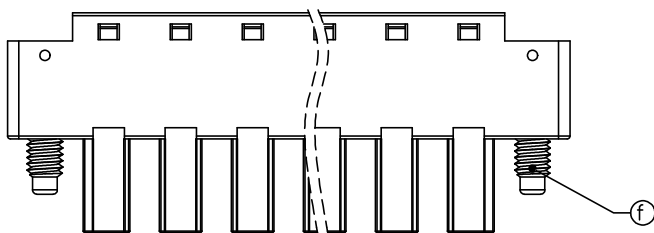

SIGN	DATE	DESCRIPTION	APPROVER
△	2009.12.28	Add UL standard	Jacke
△	2010.05.22	The design is changed	Jacke
△	04/22-15	Update the drawing	Evan

THIS IS CAD DRAWING, DO NOT REVISE MANUALLY!!!

Material

- Item (a) Terminal body: Thermoplastic (UL94V-0)
- Item (b) Terminal cover: Thermoplastic (UL94V-0)
- Item (c) Clamp: Brass, Ni plated
- Item (d) Female contact: PhBz, Bright Tin plated over Nickel plated
- Item (e) Terminal screw: Steel Cr3+ Zinc plating "+/-" slot type
- Item (f) With flange screw: steel M2.5 Zinc plating "+/-" slot type

Electrical

- Voltage rating: 300VAC
- Current rating: 10A
- Wire range:
  - Solid wire(AWG): 14-30
  - Stranded wire(AWG): 14-30
- Torque(Lb-In): 2
- Screw: M2
- Wire strip length: 7-8mm
- Withstanding Voltage: 1.6KV
- Operating temperature: -40°C to +115°C
- Soldering temperature: 260°C±5°C/5 Sec
- Safety Approval:
- Critical dimension:

Dimension

DIM A	N×5.08
DIM B	(N-1)×5.08
DIM C	(N+1)×5.08+4.12

N=Number of poles



POLES	TOL
2p-5p	±0.15
6p-9p	±0.20
10p-13p	±0.30
14p-17p	±0.35
18p-24p	±0.40

**ANYTEK**

**CUSTOMER COPY**

ALL RIGHTS RESERVED. REPRODUCTION OR ISSUE TO THIRD PARTIES IN ANY FORM WHATSOEVER IS NOT PERMITTED WITHOUT WRITTEN AUTHORITY FROM THE PROPRIETOR. PROPERTY OF ANYTEK TECHNOLOGY CO., LTD

TITLE		VR 5.08 Series With flange ( Contact on down side )					
PART NO.		VRxx51x2xxxxG		DWG NO.		8VR0002	
APPROVED	CHECKED	DESIGNED	DRAWN	CUST NO.		Tolerance	
		Evan	Evan			X. ±0.50	
		04/22-15	04/22-15			UNIT: mm	X.X ±0.30
						SCALE: NONE	X.XX ±0.10
				SHEET: 01/01		X° ±1°	