

PART NUMBER	REVISION	DESCRIPTION	FEED TYPE
2150186-1	B	FINE CRIMP HEIGHT ADJUST	MECHANICAL
2150186-2	B	FINE CRIMP HEIGHT ADJUST	PNEUMATIC
7-2150186-1	B	MECHANICAL AND CRIMP TOOLING KIT	MECHANICAL
7-2150186-2	B	PNEUMATIC AND CRIMP TOOLING KIT	PNEUMATIC
7-2150186-7	A	CRIMP TOOLING KIT	-

ATLANTIC VERSION TERMINATOR INTERFACE ADAPTER



APPLICATOR DATA		
CRIMP	SIZE	TYPE
WIRE	2.29 mm [.090]	F
INSUL	4.57 mm [.180]	F

APPLICATOR INSTRUCTIONS
408-35043

TERMINAL DATA: TE TERMINAL		TE CRIMP SPECIFICATION	
TERMINAL NAME: .187 SERIES POST-LOCK RECEPTACLE			
WIRE STRIP LENGTH		INSULATION DIAMETER RANGE	
3.68-4.45 mm [.145-.175 IN]		∅2.29-3.30 mm [.090-.130 IN]	
TERMINAL APPLICATION SPECIFICATION	114-2074		
TERMINALS APPLIED			
TE TERMINAL	TE TERMINAL	TE TERMINAL	TE TERMINAL
63195-1	63195-2	63232-1	63313-1
63520-1	1217580-1	1217715-1	

WIRE SIZE	CRIMP HEIGHT mm [INCH]	CRIMP HEIGHT REFERENCE SETTING
16 AWG	1.45 +/- 0.000 [.057 +/- .000]	4.2
18 AWG	1.27 +/- 0.000 [.050 +/- .000]	6.1
20 AWG	1.14 +/- 0.000 [.045 +/- .000]	7.7

- 1 RECOMMENDED SPARE PARTS
- 2 REFER TO SUPPLIED INSTRUCTION SHEET FOR CLEANING, LUBRICATION AND STORAGE OF APPLICATOR.
- 3 APPLY PART NUMBER 2-23419-6 LOCTITE TO THREADS OF ITEM 242. APPLY PART NUMBER 1-23419-5 LOCTITE TO THREADS OF ITEM 50.
- 4 CRIMP HEIGHT REFERENCE SETTING WAS THE SETTING USED WHEN THE APPLICATOR WAS QUALIFIED AT THE FACTORY. ADJUSTMENT MAY BE NECESSARY WHEN RUNNING APPLICATOR IN THE FIELD.
- 5. UNLESS SPECIFIED OTHERWISE TORQUE VALUES SHALL BE USED PER DOCUMENT, 101-35000.

*WARNING
ON INSTALLATION, SET WIRE DISC TO CRIMP HEIGHT REFERENCE SETTING FOR LARGEST WIRE SIZE. CRIMP HEIGHT REFERENCE SETTINGS GREATER THAN THE VALUE SHOWN MAY CAUSE DAMAGE TO THE CRIMP TOOLING. REFER TO THE INSTRUCTION SHEET FOR PROPER SETUP AND ADJUSTMENTS.

LOC	DIST	REVISIONS					
		P	LTN	DESCRIPTION	DATE	OWN	APPD
A	66	A		RELEASE	18FEB2013	L.Z	S.X
		B		ECR-21-004234	11APR2021	TB	RR

-	1	-	1	-	2119641-1	FEED CAM, AIR FEED	248					
-	1	1	1	1	2119082-9	CAM, SNAIL, INSULATION ADJUSTMENT	244					
-	1	1	1	1	2079764-1	WASHER, WAVE SPRING, CREST-TO-CREST	243					
-	1	1	1	1	2119083-1	RETAINER, INSULATION DIAL	242					
-	-	1	-	1	2119580-1	MECHANICAL FEED ASSEMBLY	239					
-	1	-	1	-	2844940-3	AIR FEED MODULE	238					
-	1	1	1	1	1-18028-0	WASHER, FLAT, REG M8	192					
-	1	1	1	1	6-993111-6	PIN, SLOTTED SPRING 3.0 X 14.0	177					
-	1	1	1	1	8-22280-7	SPRING, COMPRESSION	176					
-	1	1	1	1	1752353-2	GUIDE PIN,HOLDDOWN	175					
-	1	1	1	1	1901680-2	GUIDE PIN,HOLDDOWN	174					
-	REF	REF	REF	REF	994970-2	COUNTER, MAGNETIC	164					
-	1	1	1	1	455888-4	SPACER, CRIMPER	82					
-	1	1	1	1	1803607-4	DOCUMENTATION PACKAGE	71					
-	2	2	2	2	2-18032-2	SCR, SET, FLT PNT, M3 X 10.0	70					
-	1	1	1	1	2119740-1	TAG, IDENTIFICATION	67					
-	2	2	2	2	2168078-1	SCREW, DRIVE, RH, RoHS, 2 x .188	66					
-	1	1	1	1	1901681-9	HOLDDOWN, TERMINAL	65					
-	1	1	1	1	2168083-2	SCR, SKT HD CAP, RoHS, M4 X 8.0	60					
-	1	1	1	1	5-18022-5	SCR, HEX HD CAP, M4 X 6.0	59					
-	-	1	-	1	2063961-1	FEED FINGER	58					
-	4	4	4	4	2168400-4	SHCS, LOW HEAD, RoHS, M4 X 8	57					
-	2	2	2	2	2168083-3	SCR, SKT HD CAP, RoHS, M4 X 12.0	56					
-	2	2	2	2	5018030-1	NUT, HEX, REG, RoHS, M3	54					
-	2	2	2	2	986965-8	NUT, LOCK, HEX, TORQUE (M4)	53					
-	1	1	1	1	1-5018030-0	NUT, HEX, REG, RoHS, M3.5	52					
-	1	-	1	-	2063961-1	FEED FINGER	51					
-	1	1	1	1	1752354-8	STANDOFF,HOLD-DOWN	50					
-	1	2	1	2	18023-9	SCR, SKT HD CAP M4 X 6.0	49					
-	-	1	-	1	2119652-1	FEED CAM, PRE FEED	48					
-	-	1	-	1	2119653-1	FEED CAM, POST FEED	47					
-	1	1	1	1	2119655-5	APPLICATOR BASIC ASSEMBLY, EF	46					
-	1	1	1	1	1803517-1	RAM ASSEMBLY, EF ATLANTIC	44					
-	1	1	1	1	1803602-1	SCR, BHSC, RoHS (M8 X 25)	41					
-	8	8	8	8	1-18028-2	WASHER, FLAT, REG M4	33					
-	2	2	2	2	2168083-9	SCR, SKT HD CAP, RoHS, M4 X 20	31					
-	2	2	2	2	2168083-2	SCR, SKT HD CAP, RoHS, M4 X 8.0	29					
-	1	1	1	1	240639-1	STRIPPER (MACHINING)	27					
-	2	2	2	2	1-2168083-5	SCR, SKT HD CAP, RoHS, M4 X 30	25					
-	1	1	1	1	2-1752371-1	PLATE, STRIP GUIDE	24					
-	2	2	2	2	2-22281-3	SPRING, COMPRESSION	22					
-	1	1	1	1	1803292-4	DRAG	20					
-	2	2	2	2	1901259-4	GUIDE, LOWER STRIP	18					
-	4	4	4	4	1-2079383-1	SCR, BHSC, RoHS (M6 X 12)	17					
-	1	1	1	1	1752360-1	SPACER,HOLD-DOWN	13					
-	1	1	1	1	240833-7	PLATE, REAR SHEAR	11					
-	-	-	-	-	-	-	10					
-	1	1	1	1	690482-5	PLATE, FRONT SHEAR	9					
-	1	2	2	1	1	3-1333217-6	ANVIL, EF .090	8				
-	1	1	1	1	1	2217206-7	BLADE, SLUG	7				
-	1	1	1	1	1	6-240641-8	SPACER	5				
-	1	1	1	1	1	238011-4	BLOCK, CRIMPER SPACER	4				
-	1	2	2	1	1	4-2119582-1	CRIMPER, INSULATION F PREMIUM	3				
-	1	1	1	1	1	455888-5	SPACER, CRIMPER	2				
-	1	2	2	1	1	2-456406-3	CRIMPER, WIRE PREMIUM	1				
-	77	-	72	-	71	-	2	-	1	PART NO	DESCRIPTION	ITEM NO

ATLANTIC VERSION
Shown on sheets 1 of 4 & 2 of 4
(Pacific version shown on sheets 3 of 4 & 4 of 4)

DIMENSIONS:		TOLERANCES UNLESS OTHERWISE SPECIFIED:		DWN L. ZHANG 17SEP2012		CHK L. ZHANG 17SEP2012		NAME		TE Connectivity Harrisburg, PA 17105-3608			
mm	0 PLC ±	1 PLC ±	2 PLC ±	3 PLC ±	4 PLC ±	ANGLES ±	FINISH ±	APVD S. XI 17SEP2012	PRODUCT SPEC	SIZE	CAGE CODE	DRAWING NO	RESTRICTED TO
									APPLICATION SPEC	A1	00779	2150186	
MATERIAL		FINISH		WEIGHT		CUSTOMER ACCESSIBLE PRODUCTION DRAWING		SCALE		SHEET 1 OF 4		REV B	

PART NUMBER	REVISION	DESCRIPTION	FEED TYPE
2-2150186-1	B	FINE CRIMP HEIGHT ADJUST	MECHANICAL
2-2150186-2	B	FINE CRIMP HEIGHT ADJUST	PNEUMATIC
7-2150186-7	A	CRIMP TOOLING KIT	-

PACIFIC VERSION TERMINATOR
INTERFACE ADAPTER

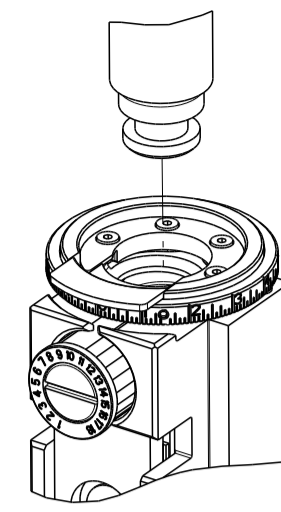

APPLICATOR DATA		
CRIMP	SIZE	TYPE
WIRE	2.29 mm [.090]	F
INSUL	4.57 mm [.180]	F
APPLICATOR INSTRUCTIONS 408-35043		

TERMINAL DATA: TE TERMINAL		TE CRIMP SPECIFICATION	
TERMINAL NAME: .187 SERIES POST-LOCK RECEPTACLE			
WIRE STRIP LENGTH		INSULATION DIAMETER RANGE	
3.68-4.45 mm [.145-.175 IN]		Ø2.29-3.30 mm [.090-.130 IN]	
TERMINAL APPLICATION SPECIFICATION	114-2074	-	-
TERMINALS APPLIED			
TE TERMINAL	TE TERMINAL	TE TERMINAL	TE TERMINAL
63195-1	63195-2	63232-1	63313-1
63520-1	1217580-1	1217715-1	

WIRE SIZE	CRIMP HEIGHT mm [INCH]	CRIMP HEIGHT REFERENCE SETTING
16 AWG	1.45+/-0.000 [.057+/- .000]	4.2
18 AWG	1.27+/-0.000 [.050+/- .000]	6.1
20 AWG	1.14+/-0.000 [.045+/- .000]	7.7

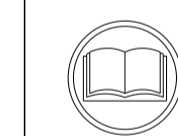

- RECOMMENDED SPARE PARTS
- REFER TO SUPPLIED INSTRUCTION SHEET FOR CLEANING, LUBRICATION AND STORAGE OF APPLICATOR.
- APPLY PART NUMBER 2-23419-6 LOCTITE TO THREADS OF ITEM 242. APPLY PART NUMBER 1-23419-5 LOCTITE TO THREADS OF ITEM 50.
- CRIMP HEIGHT REFERENCE SETTING WAS THE SETTING USED WHEN THE APPLICATOR WAS QUALIFIED AT THE FACTORY. ADJUSTMENT MAY BE NECESSARY WHEN RUNNING APPLICATOR IN THE FIELD.
- UNLESS SPECIFIED OTHERWISE TORQUE VALUES SHALL BE USED PER DOCUMENT, 101-35000.

***WARNING**
ON INSTALLATION, SET WIRE DISC TO CRIMP HEIGHT REFERENCE SETTING FOR LARGEST WIRE SIZE. CRIMP HEIGHT REFERENCE SETTINGS GREATER THAN THE VALUE SHOWN MAY CAUSE DAMAGE TO THE CRIMP TOOLING. REFER TO THE INSTRUCTION SHEET FOR PROPER SETUP AND ADJUSTMENTS.

LOC	DIST	REVISIONS					
		P	LTN	DESCRIPTION	DATE	OWN	APVD
A	66	-	-	SEE SHEET 1	-	-	-

-	1	1	2119082-9	CAM, SNAIL, INSULATION ADJUSTMENT	244	
-	1	1	2079764-1	WASHER, WAVE SPRING, CREST-TO-CREST	243	
-	1	1	2119083-1	RETAINER, INSULATION DIAL	242	
-	-	1	2119580-1	MECHANICAL FEED ASSEMBLY	239	
-	1	-	2844940-3	AIR FEED MODULE	238	
-	1	1	1-18028-0	WASHER, FLAT, REG M8	192	
-	4	4	2079383-9	SCR, BHSC, RoHS (M6 X 20)	186	
-	1	1	6-993111-6	PIN, SLOTTED SPRING 3.0 X 14.0	177	
-	1	1	8-22280-7	SPRING, COMPRESSION	176	
-	1	1	1752353-2	GUIDE PIN,HOLDDOWN	175	
-	1	1	1901680-2	GUIDE PIN,HOLDDOWN	174	
-	REF	REF	994970-2	COUNTER, MAGNETIC	164	
-	1	-	2119641-2	FEED CAM, AIR FEED	152	
-	1	1	2168083-8	SCR, SKT HD CAP, RoHS, M4 X 16	144	
-	-	1	2119653-2	FEED CAM, POST FEED	142	
-	1	1	2119655-6	APPLICATOR BASIC ASSEMBLY, EF	141	
-	1	1	1803518-1	RAM ASSEMBLY, EF PACIFIC	140	
-	1	1	455888-4	SPACER, CRIMPER	82	
-	1	1	1803607-4	DOCUMENTATION PACKAGE	71	
-	2	2	2-18032-2	SCR, SET, FLT PNT, M3 X 10.0	70	
-	1	1	2119740-1	TAG, IDENTIFICATION	67	
-	2	2	2168078-1	SCREW, DRIVE, RH, RoHS, 2 x .188	66	
-	1	1	1901681-9	HOLDDOWN, TERMINAL	65	
-	1	1	5-18022-5	SCR, HEX HD CAP, M4 X 6.0	59	
-	-	1	2063961-1	FEED FINGER	58	
-	4	4	2168400-4	SHCS, LOW HEAD, RoHS, M4 X 8	57	
-	2	2	2168083-3	SCR, SKT HD CAP, RoHS, M4 X 12.0	56	
-	2	2	5018030-1	NUT, HEX, REG, RoHS, M3	54	
-	2	2	986965-8	NUT, LOCK, HEX, TORQUE (M4)	53	
-	1	1	1-5018030-0	NUT, HEX, REG, RoHS, M3.5	52	
-	1	-	2063961-1	FEED FINGER	51	
-	1	1	1752354-8	STANDOFF,HOLD-DOWN	50	
-	1	2	18023-9	SCR, SKT HD CAP M4 X 6.0	49	
-	-	1	2119652-1	FEED CAM, PRE FEED	48	
-	1	1	1803602-1	SCR, BHSC, RoHS (M8 X 25)	41	
-	8	8	1-18028-2	WASHER, FLAT, REG M4	33	
-	2	2	2168083-9	SCR, SKT HD CAP, RoHS, M4 X 20	31	
-	2	2	2168083-2	SCR, SKT HD CAP, RoHS, M4 X 8.0	29	
-	1	1	240639-1	STRIPPER (MACHINING)	27	
-	2	2	1-2168083-5	SCR, SKT HD CAP, RoHS, M4 X 30	25	
-	1	1	2-1752371-1	PLATE, STRIP GUIDE	24	
-	2	2	2-22281-3	SPRING, COMPRESSION	22	
-	1	1	1803292-4	DRAG	20	
-	2	2	1901259-4	GUIDE, LOWER STRIP	18	
-	1	1	1752360-1	SPACER,HOLD-DOWN	13	
-	1	1	240833-7	PLATE, REAR SHEAR	11	
-	-	-	-	-	10	
-	1	1	690482-5	PLATE, FRONT SHEAR	9	
1	1	1	3-1333217-6	ANVIL, EF .090	8	
1	1	1	2217206-7	BLADE, SLUG	7	
-	1	1	6-240641-8	SPACER	5	
-	1	1	238011-4	BLOCK, CRIMPER SPACER	4	
1	1	1	4-2119582-1	CRIMPER, INSULATION F PREMIUM	3	
-	1	1	455888-5	SPACER, CRIMPER	2	
1	1	1	2-456406-3	CRIMPER, WIRE PREMIUM	1	
-	77	22	21	PART NO	DESCRIPTION	ITEM NO

PACIFIC VERSION
Shown on sheets 3 of 4 & 4 of 4
(Atlantic version shown on sheets 1 of 4 & 2 of 4)

DIMENSIONS:		TOLERANCES UNLESS OTHERWISE SPECIFIED:		MATERIAL:		FINISH:	
mm	0 PLC ±	1 PLC ±	2 PLC ±	3 PLC ±	4 PLC ±	ANGLES	FINISH
APVD		APVD		WEIGHT		SCALE	
S. XI		S. XI		A1		1:1	
PRODUCT SPEC		APPLICATION SPEC		CAGE CODE		DRAWING NO	
CUSTOMER ACCESSIBLE PRODUCTION DRAWING		SCALE		SHEET		OF	
A		00779		C=2150186		3 OF 4	
REV		B		REV		B	

LOC		DIST		REVISIONS			
A	66	P	LTM	DESCRIPTION	DATE	OWN	APVD
		-		SEE SHEET 1			

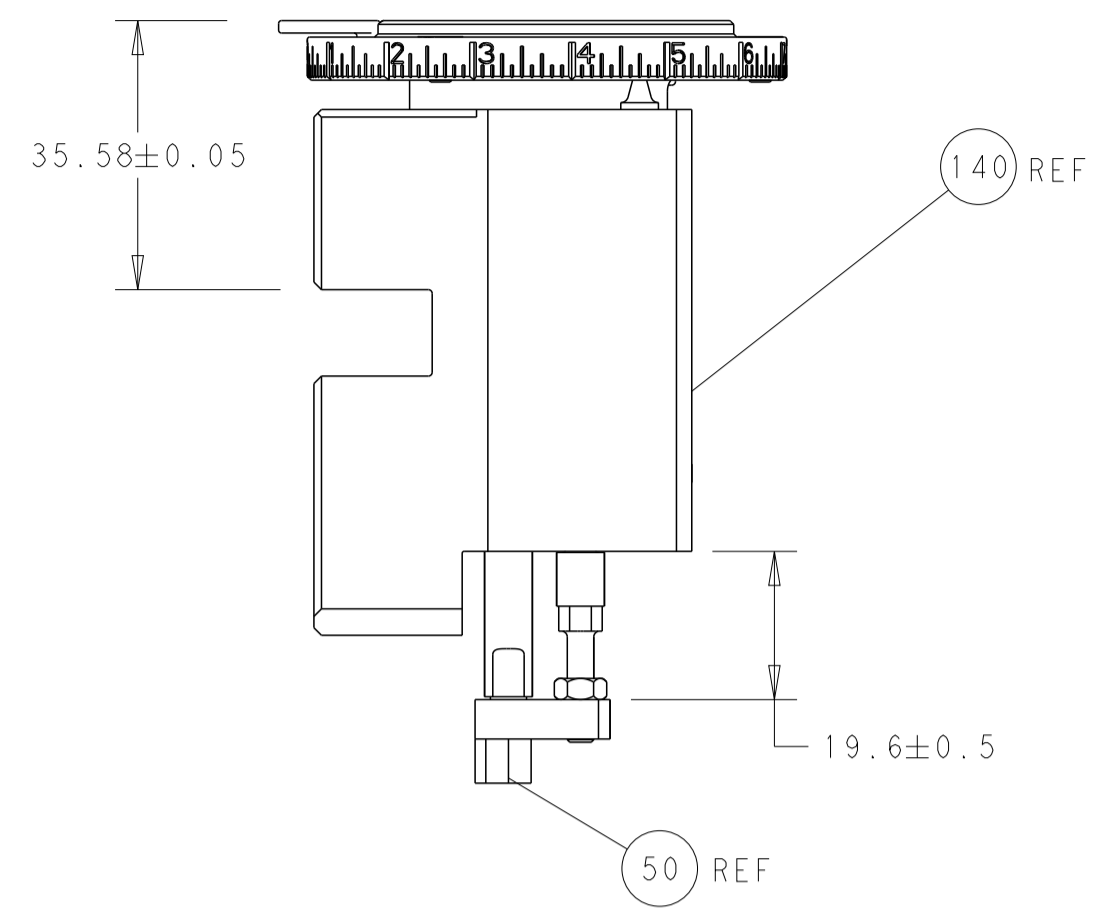

RAM AND HOLDDOWN SET-UP

FEED TYPE
MECHANICAL

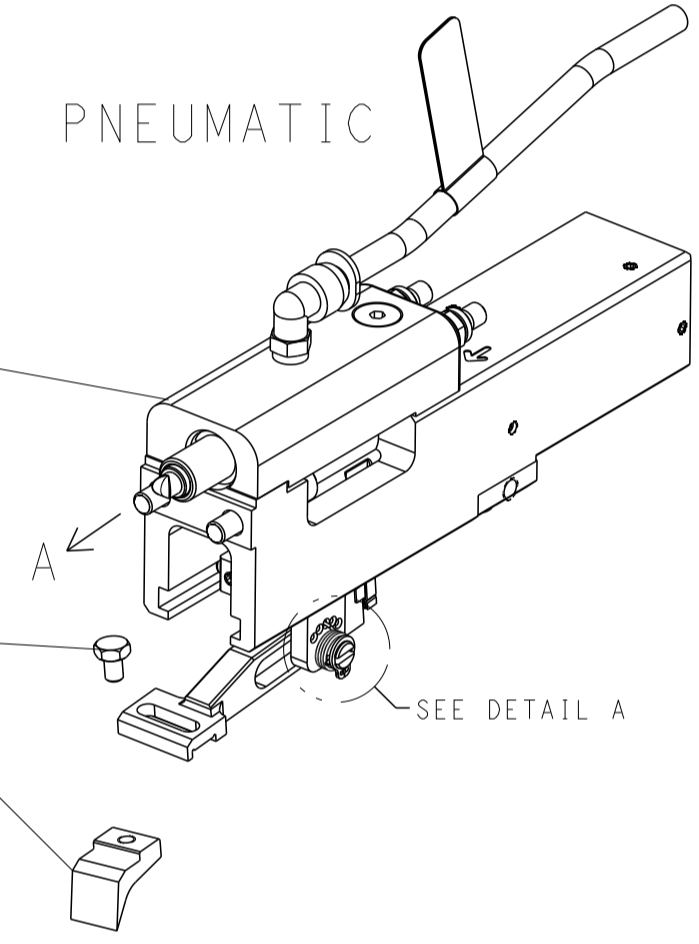
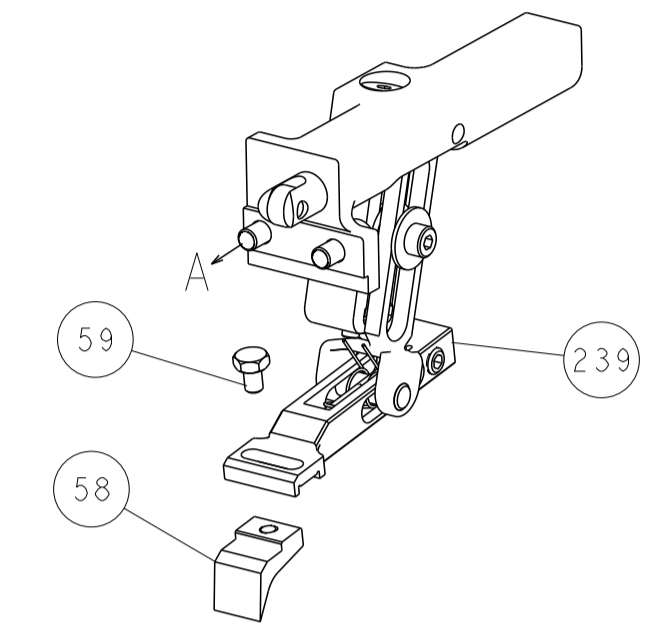

FEED SPRING
SETTING POSITION

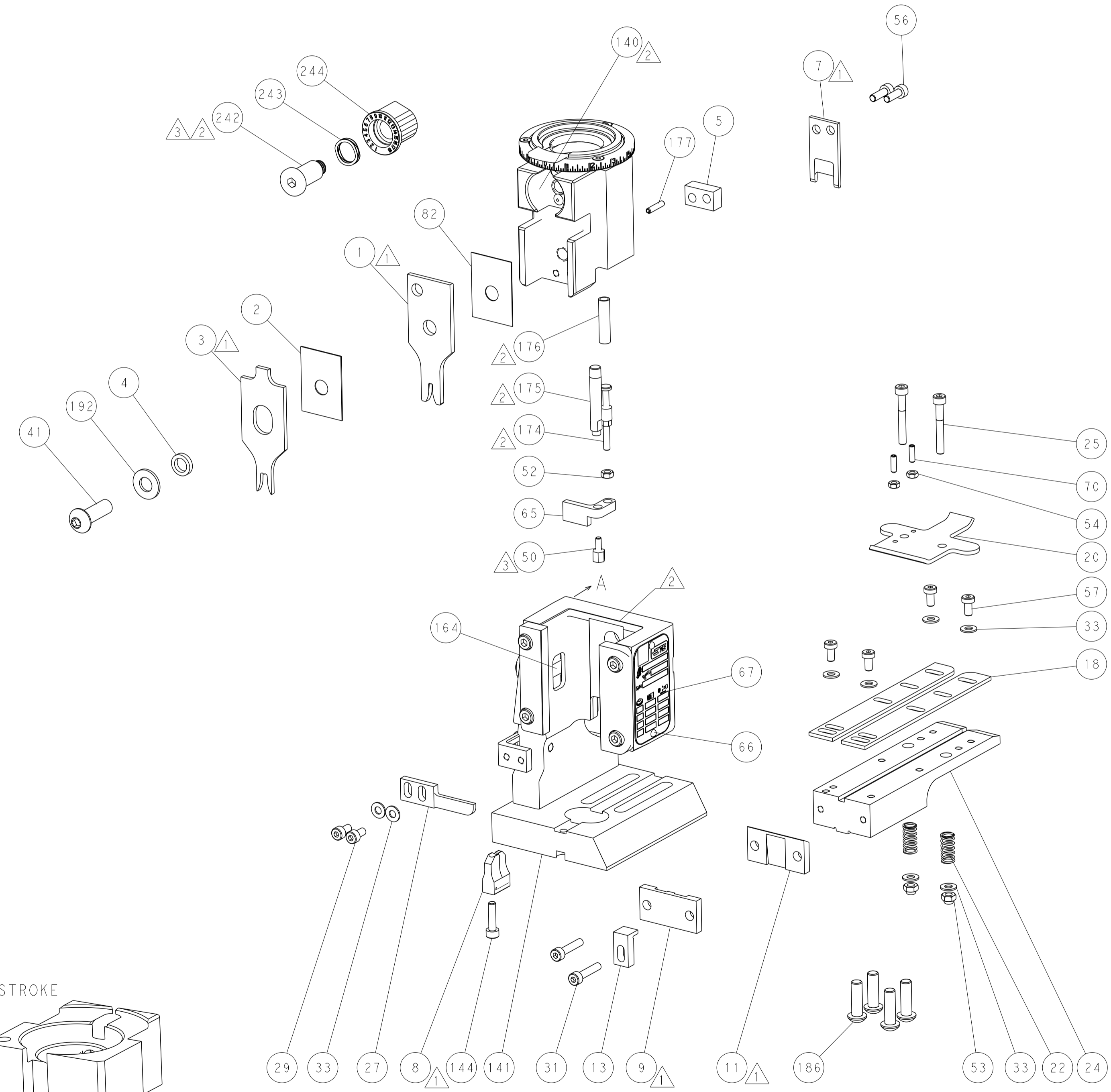
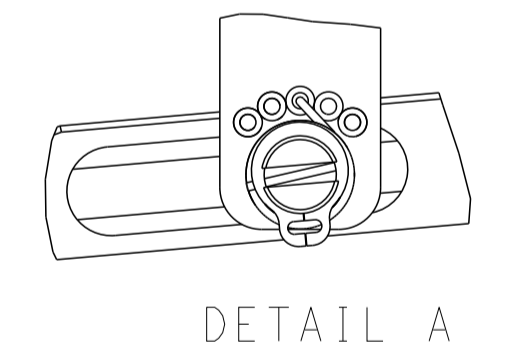

CAM POSITIONS

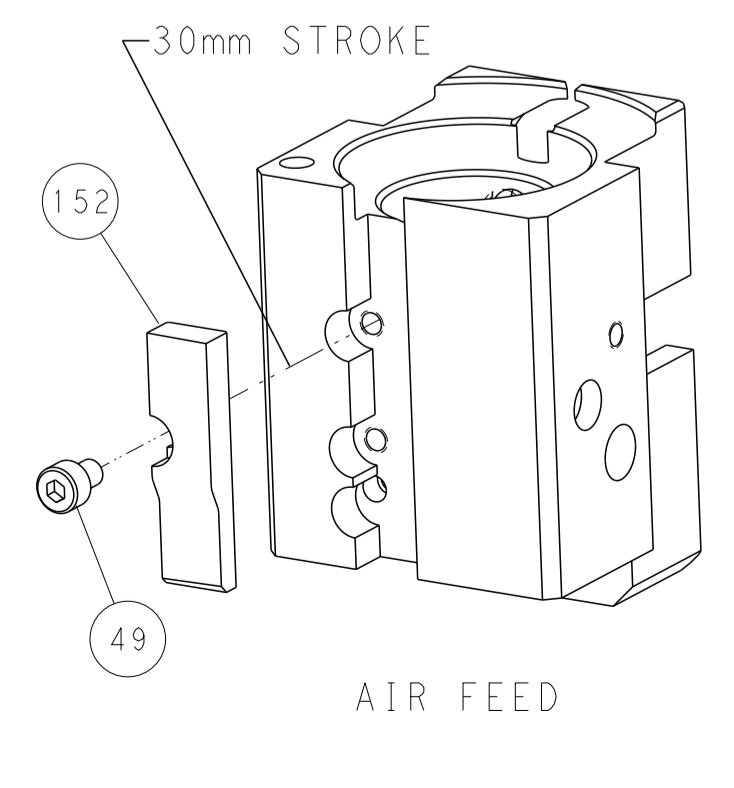
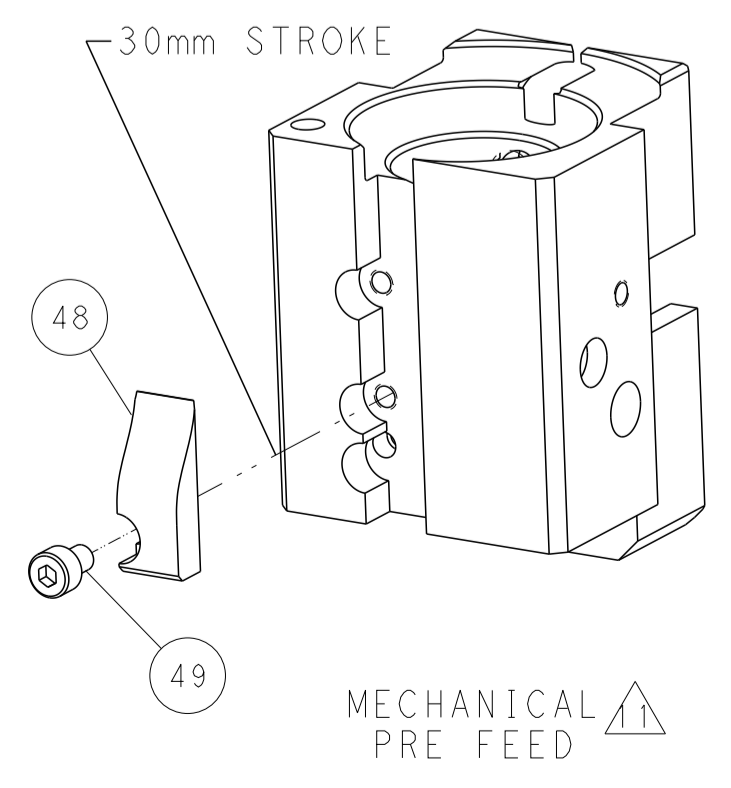
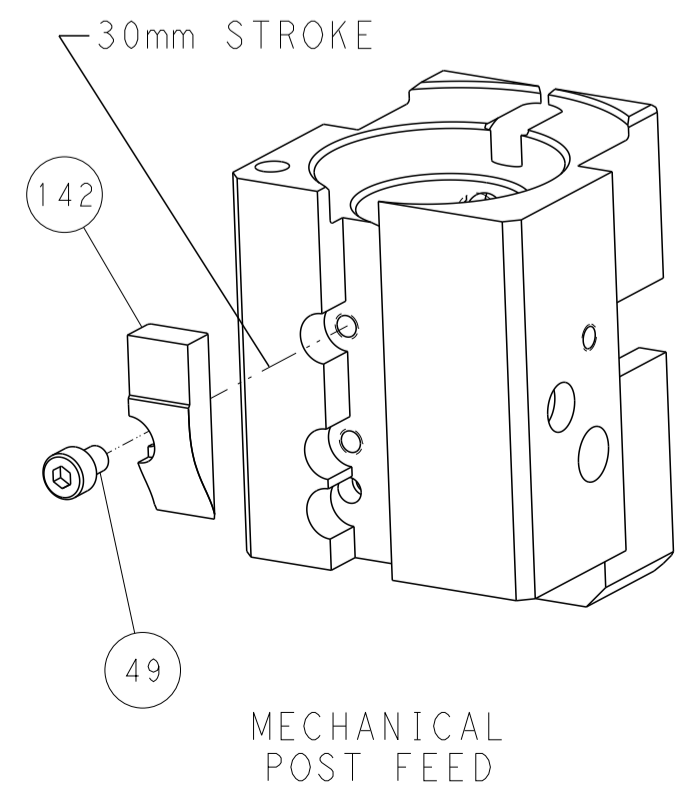

PACIFIC VERSION
 Shown on sheets 3 of 4 & 4 of 4
 (Atlantic version shown on sheets 1 of 4 & 2 of 4)

DIMENSIONS:		TOLERANCES UNLESS OTHERWISE SPECIFIED:		DWN L. ZHANG 17SEP2012		STE TE Connectivity	
mm	0 PLC ±	1 PLC ±	2 PLC ±	3 PLC ±	4 PLC ±	5 PLC ±	Harrisburg, PA 17105-3608
MATERIAL:	FINISH:	WEIGHT:	SCALE:	SIZE:	CAGE CODE:	DRAWING NO:	RESTRICTED TO:
			1:1	A1	00779	2150186	
CUSTOMER ACCESSIBLE PRODUCTION DRAWING				SHEET 4 OF 4 REV B			