

# Laser Ray Viewing Kit

## Experiment Guide



**Experiments include:** Demonstrating Snell's Law  
Total Internal Reflection  
Angles of Incidence and Reflection  
Determining Critical Angles

**Model Numbers:**

**IF 548**

**IF 549**

**INDUSTRIAL FIBER OPTICS**

\*

Copyright © 2023  
Previous printing 2009, 2008, 2002  
by Industrial Fiber Optics  
Revision - E

Printed in the United States of America

\* \* \*

All rights reserved. No part of this publication may be reproduced,  
stored in a retrieval system, or transmitted in any form or by any means  
(electronic, mechanical, photocopying, recording, or otherwise)  
without prior written permission from Industrial Fiber Optics.

\* \* \* \* \*

# **INTRODUCTION**

*This manual provides information about Industrial Fiber Optics' Light Ray Viewing Kit. It contains all the information you need to use this project kit safely and knowledgeably, even if you are a novice to this technology. Please read the manual carefully while completing activities.*

*As soon as you receive this laser, inspect it and the shipping container for damage. If any damage is found, immediately refer to the section of this manual entitled SHIPMENT DAMAGE CLAIM.*

*Industrial Fiber Optics makes every effort to incorporate state-of-the-art technology, highest quality and dependability in its products. We constantly explore new ideas and products to best serve the rapidly exscattering tankding needs of industry and education. We encourage comments that you may have about our products, and we welcome the opportunity to discuss new ideas that may better serve your needs. For more information about our products refer to [www.i-fiberoptics.com](http://www.i-fiberoptics.com).*

*Thank you for selecting this Industrial Fiber Optics product. We hope it meets your expectations and provides many hours of productive activity.*

*Sincerely,*

**The Industrial Fiber Optics Team**



# ***TABLE OF CONTENTS***

<b>Introduction.....</b>	<b>i</b>
<b>LASER CLASSIFICATIONS.....</b>	<b>iv</b>
<b>PROJECT KIT COMPONENTS.....</b>	<b>1</b>
<b>SCATTERING OF LIGHT.....</b>	<b>2</b>
<b>REFLECTION OF LIGHT.....</b>	<b>5</b>
<b>REFRACTION OF LIGHT.....</b>	<b>9</b>
<b>CRITICAL ANGLE MEASUREMENT.....</b>	<b>14</b>
<b>POLARIZATION.....</b>	<b>17</b>
<b>WARRANTY.....</b>	<b>20</b>
<b>SHIPMENT DAMAGE CLAIMS.....</b>	<b>21</b>

# LASER CLASSIFICATIONS

---

All manufacturers of lasers used in the United States must conform to regulations administered by the Center for Devices and Radiological Health (CDRH), a branch of the U.S. Department of Health and Human Services. CDRH categorizes lasers as follows:

Class	Description
I	A laser or laser system, which does not present a hazard to skin or eyes for any wavelength or exposure time. Exposure varies with wavelength. For ultraviolet, 2 to 4 $\mu\text{m}$ exposures is less than from 8 nW to 8 $\mu\text{W}$ . Visible light exposure varies from 4 $\mu\text{W}$ to 200 $\mu\text{W}$ , and for near-IR, the exposure is < 200 $\mu\text{W}$ . Consult CDRH regulations for specific information.
II	Any visible laser with an output less than 1 mW of power. Warning label requirements – yellow caution label stating maximum output of 1 mW. Generally used as classroom lab lasers, supermarket scanners and laser pointers
IIIa	Any visible laser with an output over 1 mW of power with a maximum output of 5 mW of power. Warning label requirements – red danger label stating maximum output of 5 mW. Also used as classroom lab lasers, in holography, laser pointers, leveling instruments, measuring devices and alignment equipment.
IIIb	Any laser with an output over 5 mW of power with a maximum output of 500 mW of power and all invisible lasers with an output up to 400 mW. Warning label requirements – red danger label stating maximum output. These lasers also require a key switch for operation and a 3.5-second delay when the laser is turned on. Used in many of the same applications as the Class IIIa when more power is required.
IV	Any laser with an output over 500 mW of power. Warning label requirements – red danger label stating maximum output. These lasers are primarily used in industrial applications such as tooling, machining, cutting and welding. Most medical laser applications also require these high-powered lasers.

# PROJECT KIT COMPONENTS

---

Table 1 lists all components included in the Light Viewing Kit. Before going any further, identify each component listed in the table.

**Table 1. Project kit component list.**

General Description	Part Number	Quantity
Scattering Tank	IF-410060	1
First Surface Mirror	830045	1
Scattering Solution	IF-850005	120 ml (4 oz)
Protractor	IF-LT1-RP6	1
6" Ruler	IF-370120	1
Stirring Rod	370150	1
Manual	120257	1
4" X 1/2" Acrylic Rod	IF-ACR	1
1" Square Polarizing Filter	IF-PF1	1

Items required to complete the activities in this project kit but not included are listed in Table 2 below.

**Table 2. Additional component list.**

Name	Description	Quantity
Laser	.5 mW or larger visible diode or helium neon laser	1
Distilled Water		7 liters
Salt	Common household variety	2 tbsp
White Sugar	Common kitchen cooking variety	6 ml
Paper Towels	Common household variety	1 roll

# SCATTERING OF LIGHT

---

Light is a fascinating form of energy. It travels faster than anything else known to man. In a vacuum it moves along at  $2.96 \times 10^8$  meters per second (186,000 miles per hour) and it is only slightly slower in the air around us.

Energy can not be directly seen and it has no mass, but it can be measured, sensed or otherwise detected.

Think of a common light bulb. None of us can actually see its light energy traveling through air, but we can see its illumination reflected from this laboratory manual or the walls of this room. A beam of light, including a beam of laser light, is also a stream of energy. The reason a laser beam can be seen (as in a “laser light show,” for instance) is that small particles in the path of the beam scatter some of the light as it travels through the air. This scattering of light is then detected by the human eye.

During this lab activity we will demonstrate that water is relatively transparent to a laser beam. We will learn that only when tiny particles are introduced into the water is laser light visible to our eyes.

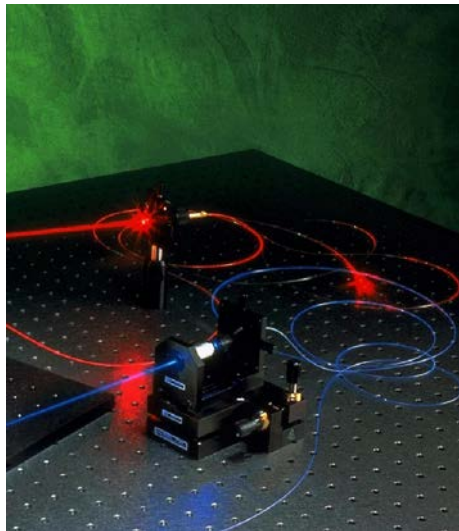

**Photo 1.**

**Double exposure of photographic film created the picture above. One exposure captured the equipment and the second exposure captured an image of light after a gas like carbon dioxide was introduced to scatter the light.**



## Equipment Needed:

- Laser beam stop
- Scattering tank
- Stirring rod
- 3.4 liters distilled water
- Scattering solution
- Table salt\*
- Paper or cloth towels\*
- Laser\*
- Laser power adapter\*

\* Not included in project kit.

## Procedure:

1. Choose a flat, level surface about 60 × 120 cm (2 × 4 feet) in size.
2. Collect all the items listed in the EQUIPMENT NEEDED section above.
3. Review the laser safety steps on the back cover of this manual if this is your first time operating a laser.
4. Position the laser, the scattering tank and the laser beam stop as shown in Figure 1.
5. Push the laser shutter's handle downward to its closed position.
6. Make sure the laser's ON/OFF switch (SW) is in its OFF position. (The push button should be in its extended position.)

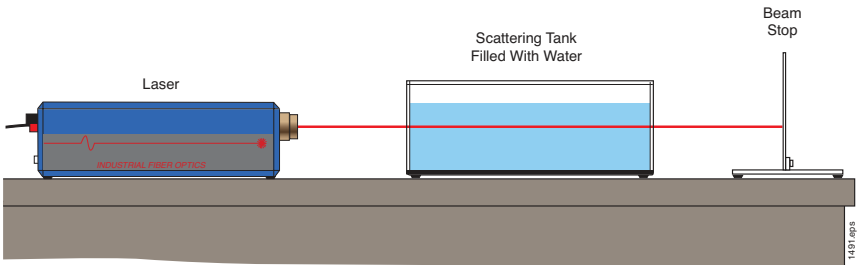

**Figure 1. Side view of the laser, scattering tank of water and beam stop.**

7. Plug the 110 VAC-to-DC power adapter (provided with the laser) into a 110-volt AC electrical outlet.
8. Plug the cord from the power adapter into the power jack (PWR) located on the rear of the laser.
9. Depress the ON/OFF switch (SW) on the control scattering tank of the laser until it clicks into the ON position. (The switch should be slightly depressed.)
10. The pilot light (green LED) on the laser should now be lit, showing that it is on.

11. Pour 1.7 liters (about 1.5 quarts) of distilled water into the scattering tank.
12. Push the laser shutter handle upward, to its open position.
13. Dim the room lights to help you observe the laser beam. Look for the laser beam traveling through the water in the scattering tank. Do you see the laser beam? Why or why not?
14. Add seven drops of scattering solution to the water in the scattering tank. Stir the water gently with the stirring rod for several seconds.
15. The laser beam should now be much more visible, as a pencil-thin beam traveling through the water.
16. Close the laser beam shutter.
17. Dispose of the water from the scattering tank in a drain and replace it with fresh distilled water.
18. Place the scattering tank in the same position as before, then open the laser beam shutter again.
19. Add one teaspoon of salt to the water and stir it with the stirring rod until it dissolves.
20. Is the laser beam clearly visible? Why or why not?
21. Add another teaspoon of salt to the water and stir. Why does adding more salt to the water not make the laser beam more visible? How is the salt different than the scattering solution in making the laser beam visible?
22. Close the laser beam shutter and switch off the laser.
23. Dispose of the water in a drain and then dry all the components with towels. Carefully replace all materials in their proper storage containers.

# REFLECTION OF LIGHT

---

In the previous activity you learned about the scattering of light. In this activity you will see a demonstration of the physics principle of the “angle of reflection” being equal to “angle of incidence.”

For a reflection off a surface to occur, the surface must be very smooth. The surfaces of water, regular household mirrors and shiny aluminum have a surface roughness less than  $1/10$  of a visible wavelength.

Nature itself provides us with one such mirror surface that is well known to us — water. Water’s mirrored surface causes sunlight to be reflected, which doubles our exposure to the sun’s rays when we are swimming and boating. This double exposure can produce severe sunburn.

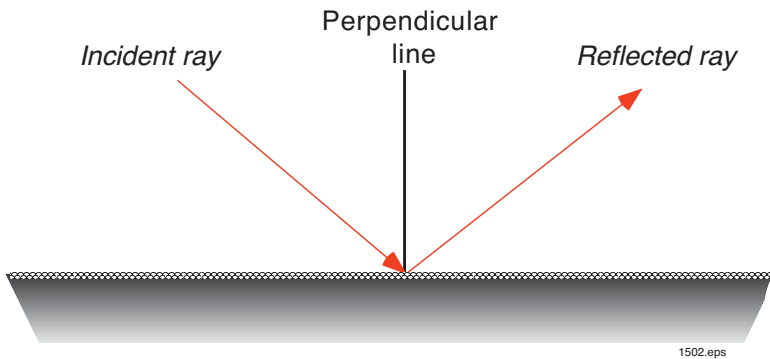

**Figure 2. Microscopic view of the surface of a mirror compared to a wavelength of light. The surface roughness of the reflector must be much smaller than the wavelength of light.**

Although many of us use mirrors only for cosmetic purposes, mirrors have other purposes as well. In laser technology alone, mirrors are used to control and direct laser beams in applications such as:

- Laser light shows
- Robotic arms for laser welding, drilling, and cutting
- Rangefinders, as used by military tanks.
- Surgery such as laser radial keratotomy
- Reflectors for positioning space shuttles and satellites in orbit
- Bar code scanners at supermarket checkout counters
- Telescopes
- Surveying equipment

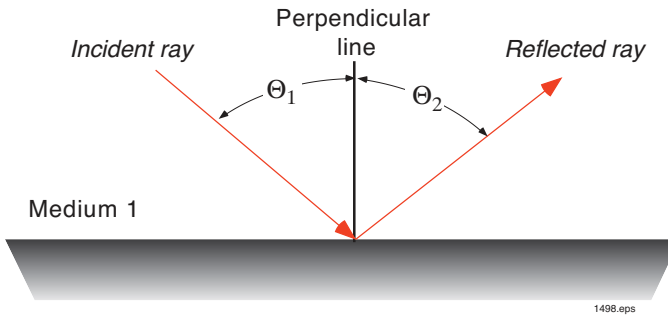

**Figure 3. Light rays intersecting at a mirror.**

**Incident rays** - optical rays traveling toward a surface.

**Reflected rays** - optical rays that have “bounced” off a surface.

$\square_1$  - **angle of incidence** - the angle formed between an incident ray of light striking a surface and a perpendicular line drawn to that surface at the point of incidence.

$\square_2$  - **angle of reflection** - the angle formed between a reflected ray of light leaving a surface and a perpendicular line drawn to that surface at the point of incidence.

### Equipment Needed:

- Scattering tank
- Laser beam stop
- Small mirror
- Scattering solution
- Stirring rod
- Protractor
- Paper or cloth towels\*
- Laser\*
- Laser power adapter\*
- 1.7 liters distilled water\*

\* Not included in project kit.

## Procedure:

1. Choose a flat, level location approximately  $60 \times 120$  cm ( $2 \times 4$  feet) in size.
2. Collect all of the items listed in the EQUIPMENT NEEDED section. Place the protractor in the bottom of the scattering tank as shown in Figure 4.
3. Using the magnetic strips on the scattering tank and mirror attach the mirror to the exterior.
4. Pour 1.7 liters (about 1.5 quarts) of distilled water into the scattering tank.
5. Add seven drops of scattering solution to the water in the scattering tank. Stir water gently for several seconds with the stirring rod.
6. Roughly align the laser so its beam will pass over the center of the protractor as shown in Figure 4.

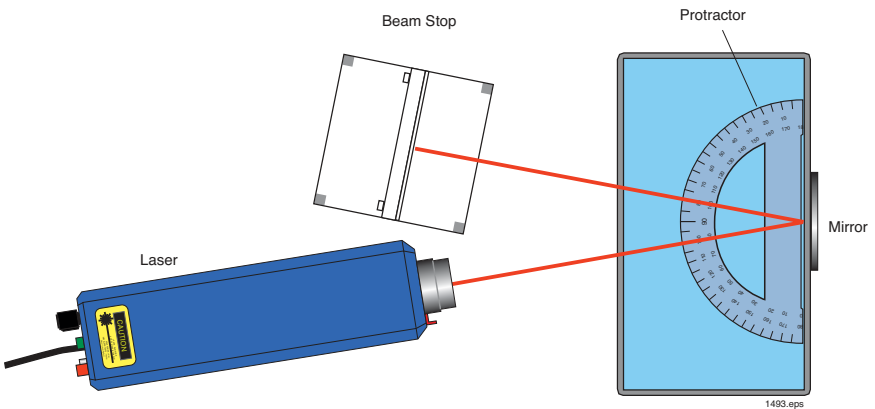

**Figure 4. Overhead view of the laser, protractor and scattering tank of water.**

7. Position the beam stop so the laser beam reflecting from the mirror will strike the beam stop as shown in Figure 4.
8. Check to ensure that the laser beam shutter is closed.
9. Plug one end of the laser power supply jack into the laser and the other end into a 110-volt AC electrical outlet.
10. Plug the cord from the power adapter into the power jack (PWR) located on the rear of the laser.
11. Depress the ON/OFF switch (SW) on the control scattering tank of the laser until it clicks into the ON position. (The switch should be slightly depressed.) The pilot light (green LED) should now be lit, showing that the laser is on.
12. Push the laser shutter's handle upward, to its open position.
13. Dim the room lights to help you observe the laser beam more clearly.

14. Double-check to be sure the laser beam stop is directly in line with the reflected laser beam.
15. Looking down at the scattering tank, observe the laser light beam traveling through the water. If necessary, to improve visibility of the beam, add several more drops of scattering solution to the water.
16. The laser beam should be visible as a pencil-thin beam traveling through the water, reflecting off the mirror, and ending at the beam stop.
17. Stand above the experiment and look down on it so you can see the laser beam and components as shown in Figure 5.
18. Align the incident laser beam over the center and the  $10^\circ$  mark on the protractor as shown in Figure 5.

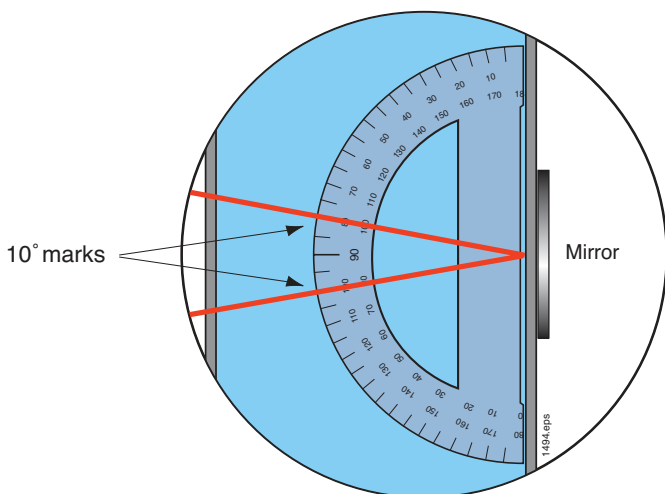

**Figure 5. Detail of laser beam alignment with the protractor.**

19. What is the angle of the reflected beam? Is it the same as the incident beam angle?
20. From your own observations in this activity would you agree with the physics principle that the angle of reflection equals the angle of incidence from mirrored surfaces?
21. Realign the laser beam so it strikes the mirror at both the  $20^\circ$  mark and the center of the protractor.
22. What is the angle of the reflected beam? Is it the same as the incident beam angle?
23. Summarize in your own words your observations about angles of incidence and reflection.
24. Dispose of the water in a drain and then dry all the components with towels. Carefully replace all materials in their proper storage containers.

# REFRACTION OF LIGHT

---

In the previous activity we saw how light could be made to change direction, by reflection. In this activity we will learn about materials' ability to "refract" light rays (refract means to bend or to deflect). Refraction of light is a scientific phenomenon that occurs in all lenses. It allows the lenses to focus and lets different refractive element to otherwise utilize these effects for various optical purposes. Refraction is what makes lenses useful for enlarging small or distant objects. Some applications of lenses are:

- Telescopes
- Microscopes
- Eyeglasses
- Magnifying glasses

Refraction of light rays occurs:

- as light rays cross the boundary between two materials, and
- when two materials have different refractive indices.

A material's refractive index is used to help describe the refraction effect as light rays pass from that material to another. Refractive index is abbreviated "n". The refractive index of a perfect vacuum is 1. All other materials have a refractive index greater than 1. A material's refractive index equals the speed of light in a vacuum, divided by the speed of light in that material.

$$n = \frac{\text{Velocity in vacuum}}{\text{Velocity in medium}}$$

Examples of optical refraction you may have encountered in your everyday life are:

- Air-to-glass: eyeglasses
- Air-to-plastic: lenses in inexpensive disposable cameras
- Air-to-water: a rainbow
- Diamond-to-air: the sparkle from a diamond

**Table 3. Refractive indices of some common materials.**

Materials	n
Air	1.00029
Water	1.33
Glass	1.50
Gasoline	1.31
Plastic	1.47 - 1.6
Diamond	2.5

The amount of bending that occurs when a light ray travels from one medium to another depends on the refractive indices of the two materials and the angle of the incident ray striking the boundary between the two mediums. The angles of incidence and refraction are measured from a line perpendicular to the surface. The mathematical relationship between the incident rays and the transmitted rays was first predicted by a scientist named Willebrord Snell (1591-1626). Snell's Law mathematically describes how light bends when it passes through a boundary between two materials ("media") that will conduct light.



**Photo 2.** Willebrord Snell is best known for the law of refraction, a basis of modern geometric optics that became known only after his death.

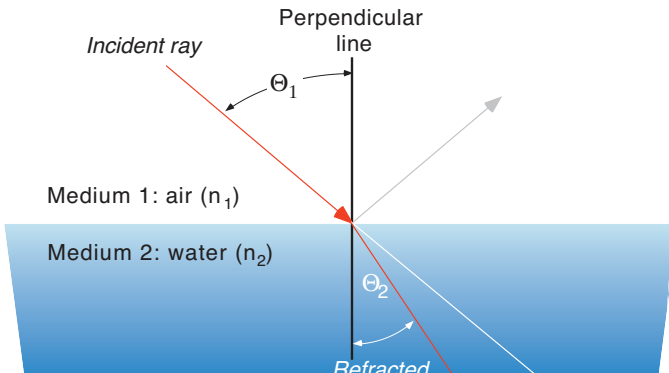

**Figure 6.** How light bends when traveling through adjacent materials with different refractive indices.

Columns one and two of Table 4 show how the refraction of light becomes greater as the approaching angle  $\theta_1$  becomes greater. The difference between the incident and refracted angles  $\theta_1$  and  $\theta_2$  becomes even more apparent by further comparing column three (which has the highest refractive index) with the first two columns.



**Table 4. Refraction angles of a light ray traveling from air through water or glass.**

Incident angle $\Theta_1$ (Air)	Refracted angle $\Theta_2$ (Water)	Refracted angle $\Theta_2$ (Glass)
0°	0°	0°
10°	7.5°	6.6°
20°	14.9°	13.1°
30°	22.0°	19.5°
40°	28.8°	25.4°
50°	35.1°	30.7°
60°	40.5°	35.2°

**Equipment Needed:**

- Scattering tank
- Laser beam stop
- Scattering solution
- Stirring rod
- Protractor
- 15 cm (6 inch) ruler
- Laser\*
- Laser power adapter\*
- White sugar\*
- 1.7 liters distilled water\*

\* Not included in project kit.

**Procedure:**

1. Choose a flat, level surface about 60 × 120 cm (2 × 4 feet) in size.
2. Collect all of the items listed in the EQUIPMENT NEEDED section. Position all the items as shown in Figure 7. Place the white side of the beam stop facing the laser beam.
3. Pour 1.7 liters (1.5 quarts) of warm water (65°C /150 °F) into the scattering tank.
4. Add seven drops of scattering solution to the water in the scattering tank. Stir gently for several seconds.
5. Check to ensure that the laser beam shutter is closed.
6. Plug one end of the laser power adapter into a 110 VAC outlet.
7. Plug the other end of the power adapter into the power jack (PWR) located on the rear of the laser.

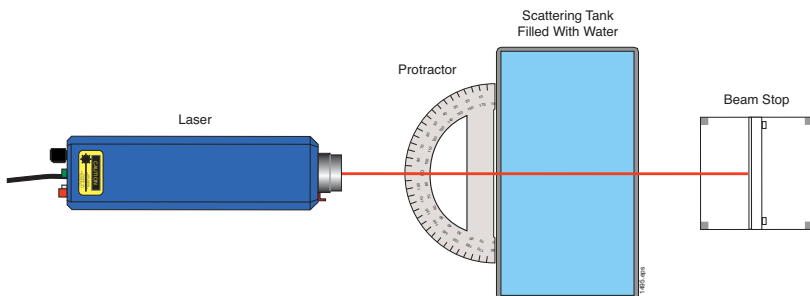

**Figure 7. Top view of the equipment setup for observing refraction.**

8. Depress the ON/OFF switch (SW) on the control scattering tank of the laser until it clicks into the ON position. (The switch should be slightly depressed.)
9. The pilot light (green LED) should now be lit, showing that the laser is on.
10. Push the beam stop's handle upward, to its open position.
11. Double-check to be sure the laser beam stop is in the path of the laser beam as shown in Figure 7.
12. Align the laser beam with any predetermined point on the beam stop.
13. Move the scattering tank out of the path of the laser. Observe the position of the laser light spot on the beam stop.
14. Move the scattering tank back into the path of the laser and rotate it approximately  $30^\circ$  in relation to the laser beam, using the protractor as a reference as shown in Figure 8.
15. Observe the bending of laser beam light by looking down from directly above the laser as shown in Figure 8.

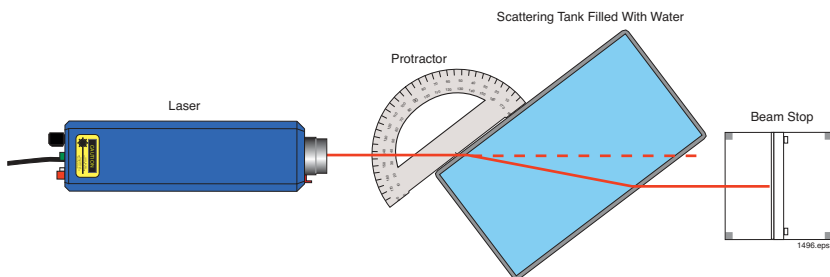

**Figure 8. Top view of the laser beam changing direction as it travels through the water.**

16. Dim the room lights to help you observe the laser beam more clearly.
17. Using the ruler, measure how far the laser beam spot moved from the predetermined point on the laser beam stop when the tank was rotated  $30^\circ$ . Why did this beam movement occur?

18. Now rotate the scattering tank approximately  $60^\circ$  in relation to the laser beam.
19. Measure with the ruler how far the laser beam spot moved on the laser beam stop when the scattering tank was rotated  $60^\circ$ . Write that value in Table 5.
20. Pour 30 ml (one half cup) of sugar into the water mixture and stir until dissolved.
21. Add another 30 ml (one half cup) of sugar and stir until it also totally dissolves. (If the water is cold, the sugar may not dissolve.)
22. Observe the increase in bending of light rays by looking down from directly above the laser as shown in Figure 8. Does the laser light beam appear to bend more when sugar is dissolved in water? Why or why not?
23. Measure the increase in deflection of the laser beam when sugar is added and record your findings in Table 5.

**Table 5. Student observation log.**

	X - (Displacement)
Water	
Water with Sugar	

24. Explain below why you think the laser beam deflected more when the sugar was added to the water. What conclusion would you make about the change in refractive index when sugar is added to the water?
25. Dispose of the sugar water in a drain, dry all the components with towels and carefully replace all materials in their proper storage containers.

# CRITICAL ANGLE MEASUREMENT

In some cases, light rays which strike the boundary between two optical media may be reflected back into the material from which they were trying to escape, rather than continuing on into the second medium. What makes the difference is the incident angle at which they strike the boundary, as well as the respective refractive indices of the two materials involved.

If light traveling through one material intercepts a boundary with another material having a lower refractive index, and if it strikes the boundary at a low enough, or “glancing” angle, it cannot refract or bend enough to get out of the first material. All the light is reflected back into the higher-index material through which it had already been traveling. The exact angle at which this occurs is called the “critical angle”.

As with incidence and reflection angles discussed previously, the critical angle is measured from the perpendicular to the boundary, as shown in Figure 9. Light rays that strike the boundary at less than the critical angle will pass through into the second medium. Light rays that strike the boundary at greater than the critical angle will be reflected back into the first. It is different for each combination of two optical materials with differing refractive indices. This angle can be calculated mathematically, but the computation is beyond the scope of this activity.

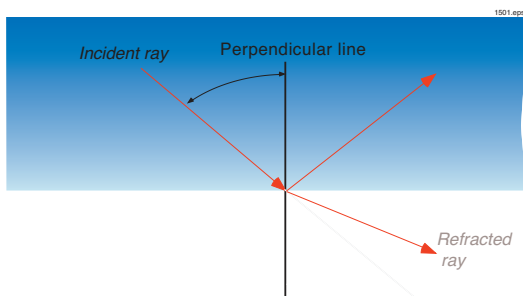

Figure 9. Light rays refracting at a boundary.

## Equipment Needed:

- Scattering tank
- Laser beam stop
- Scattering solution
- Stirring rod
- Protractor
- 1.2 × 10 cm acrylic rod
- Laser\*
- Laser power adapter\*
- Paper or cloth towels\*
- 1.7 liters distilled water\*

\* Not included in project kit.

## Procedure:

1. Choose a flat, level surface about  $60 \times 120$  cm ( $2 \times 4$  feet) in size.
2. Collect all of the items listed in the EQUIPMENT NEEDED section. Position all the items as shown in Figure 10.
3. Pour 1.7 liters (1.5 quarts) of distilled water into the scattering tank. Add seven drops of scattering solution and stir gently.
4. Position the laser so that it points toward the left end of the scattering tank, as shown in Figure 10, but pointed at the end of the tank so that the beam will strike it at an angle of approximately 45 degrees.

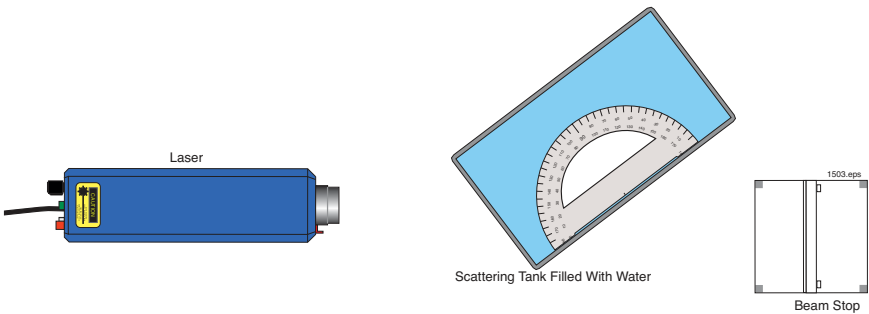

**Figure 10. Top view of the setup for determining a critical angle.**

5. Check to ensure that the laser beam shutter is closed.
6. Plug one end of the laser power adapter into a 110 VAC outlet and the other end into the laser. Plug the cord from the power adapter into the power jack (PWR) located on the rear of the laser.
7. Depress the ON/OFF switch (SW) on the control scattering tank of the laser until it clicks into the ON position. (The switch should be slightly depressed.) The pilot light (green LED) should now be lit, showing that the laser is on.
8. Push the beam stop's handle upward, to its open position.
9. Observe the path of the laser beam through the scattering tank from above. Determine if the laser beam is internally reflected inside the scattering tank or exits the scattering tank.
10. If the laser beam is not reflecting inside the scattering tank, move the tank in the direction shown in Figure 11. Rotate the laser so its beam totally reflects inside the scattering tank.

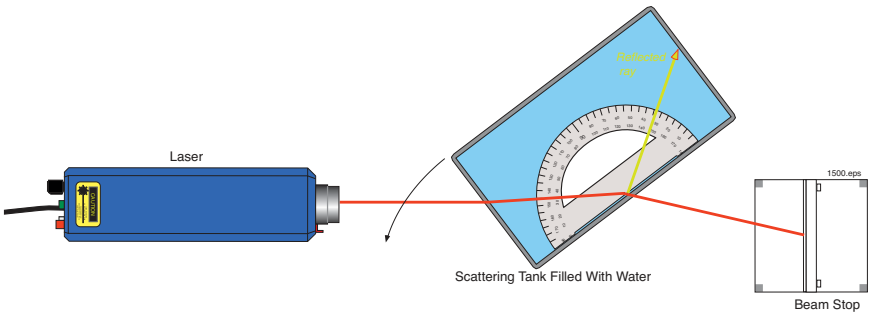

**Figure 11. Total internal reflection of the laser beam.**

11. Place the protractor in the scattering tank and observe the point (angle) that the beam passes over the protractor.
12. The angle that you just measured is the “critical angle” between water and air. Although there is an acrylic wall between the water and the air, it does not make any practical difference when computing the resulting angle.
13. Critical angle is the optical principle that keeps light contained inside fiber optical cables. Critical angle reflections allow light to be reflected with almost no loss of light energy.
14. To observe critical angle in another manner hold the 10 cm (4-inch) acrylic rod so the laser beam enters one end of the rod as shown in Figure 12. Carefully look for the laser beam reflecting down the rod.
15. Adjust the angle of the acrylic rod in relation to the laser beam so you can see the laser beam bouncing down the rod.
16. The light reflecting off all surfaces of the acrylic rod and back into its core is an example of total internal reflection. Total internal reflection is the means by which light can be transmitted long distances by optical fiber.
17. Unplug electrical components, dry all wet materials with towels and carefully replace all kit materials in their proper storage containers.

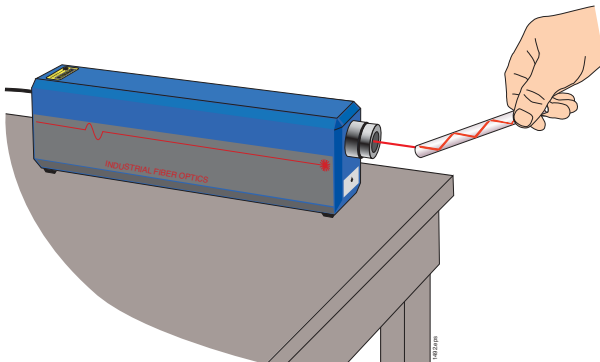

**Figure 12. An acrylic rod being used to demonstrate total internal reflection.**

# POLARIZATION

---

All *waves*, including light waves, possess one of two different types of motion. Sound waves are *compressional* motion (like compressing, then releasing a spring). Light waves, however, are *transverse*. To visualize transverse waves, imagine holding one end of a 10-foot-long rope in one hand. The other end of the rope is fastened to a wall, and you are pulling it tight, so it extends in a horizontal line. Now move that hand up/down, right/left and circular in random patterns. With these motions you are creating a visual model of a transverse light wave. Energy, or light, begins at your hand and ends up at the wall. All energy or waves that you created in the rope are *unpolarized* because there is no defined pattern or motion. Sunlight is unpolarized, as is light from most light sources except lasers

Conversely, a linearly *polarized* wave travels in a known and nonvarying pattern, as if you were to move the rope only up/down.

Unpolarized waves can be filtered/transformed into polarized waves if we use special materials with slots or gratings in them. Imagine the rope passing through a grating with only vertical slots, as shown above. The slot prevents sideways motion, but freely allows the vertical components of vibration to pass.

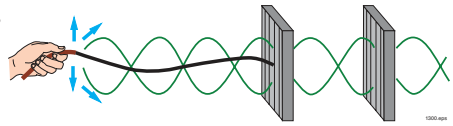

Placing a second vertical grating behind, and aligned with, the first will still allow the vibrations to pass through both sets of slots freely. However, if we turn the second grating to a horizontal position, none of the vertical light/waves exiting the first grating will pass through or be transmitted by the second grating.

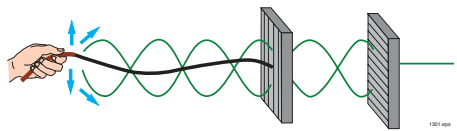

The polarizing filter in the Light Ray Viewing Kit will act like the gratings described above. Imbedded in the plastic are molecules that allow only light waves of a certain polarization to pass through. When unpolarized light passes through a linear polarizing filter, it emerges as polarized light vibrations in a single plane – although with one-half the intensity.

The laser you will likely have used in these experiments thus far is a helium neon or diode laser. Helium-neon lasers can produce light that is random, uniformly or linearly polarized. Diode lasers always produce linearly polarized light. The following procedure can be used to determine the type of polarization present in the beam of your laser.

## Equipment Needed:

- Polarization filter
- Laser beam stop
- Laser\*
- Laser power adapter\*

\* Not included in project kit.

## Procedure:

1. Choose a flat, level surface about  $60 \times 120$  cm ( $2 \times 4$  feet) in size.
2. Collect all of the items listed in the EQUIPMENT NEEDED section. Position all the items as shown in Figure 13. Place the white side of the beam stop facing the laser beam so the beam will strike it in the center.

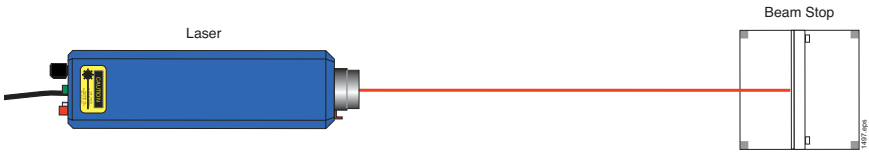

**Figure 13. Overhead view of the equipment setup for determining the type of polarized light your laser produces.**

3. Check to ensure that the laser beam shutter is closed.
4. Plug one end of the laser power supply jack into the laser and the other into a 110-volt AC electrical outlet.
5. Depress the ON/OFF switch (SW) on the control scattering tankel of the laser until it clicks into the ON position. (The switch should be slightly depressed.)
6. The pilot light (green LED) should now be lit, showing that the laser is on. Push the beam stop's handle upward, to its open position.
7. Hold the polarization filter in the path of the laser beam between the laser and the beamstop. Hold the filter stationary, at a  $90^\circ$  degree angle to the beam, as shown in Figure 14.

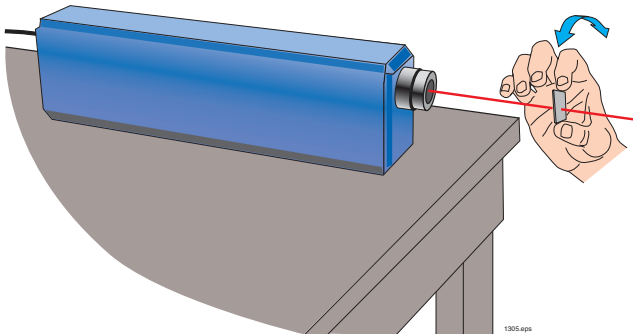



**Figure 14. Side view showing proper position of the polarization filter.**

8. Observe the beam pattern on the beam stop for about 60 seconds. If the beam varies in brightness, your laser is randomly polarized. If the brightness is constant, your laser is either linearly or uniformly polarized. In the latter case, rotate the polarization filter a complete 360 degrees, as shown in Figure 14.
9. Observe the beam pattern as the polarization filter is rotated. If the brightness did not change, the laser is uniformly polarized. If there are two rotational positions where the brightness is greatly diminished, your laser is linearly polarized.
10. What type of polarization does your laser produce?
11. Carefully disconnect all electrical connections and replace all materials in their proper storage containers.

Polarizing material is used in sunglasses, photography and many other applications. When polarizing light scattering tankels are placed in office buildings they can reduce lighting levels and still produce better viewing conditions. This both conserves energy and creates more comfortable working conditions. Polarized sunglasses reduce glare from water because the majority of light reflecting from water is in one plane.

# WARRANTY

---

Industrial Fiber Optics products are warranted against defects in materials and workmanship for 90 days. The warranty will be voided if internal or external components have been damaged, mishandled, or altered by the buyer.

Warranty liability is limited to repair or replacement of any defective unit at the comscattering tanky's facilities, and does not include attendant or consequential damages. Repair or replacement can be made only after failure analysis at the factory. Authorized warranty repairs are made at no charge, and are guaranteed for the balance of the original warranty.

Industrial Fiber Optics offers to pay the return freight for warranty repair within the continental United States by United Parcel Service. Any other delivery means must be paid for by the customer.

If an item is not under warranty, repairs will not be undertaken until the cost of such repairs has been approved, in writing, by the customer. Typical repair costs start at \$65 and repairs usually take 1 to 2 weeks to complete.

When returning items for analysis and possible repair, please do the following:

In a letter, describe the problem, person to contact, phone number and return address. Contact us to request an RMA number.

- Pack the laser, power adapter, manual and letter carefully in a strong box with adequate packing material to prevent damage in shipment.
- Ship the package with assigned RMA number to:

## **INDUSTRIAL FIBER OPTICS**

1725 WEST 1ST STREET  
TEMPE, AZ 85281-7622

# SHIPMENT DAMAGE CLAIMS

---

If damage to an Industrial Fiber Optics product should occur during shipping, it is imperative that it be reported immediately, both to the carrier and the distributor or salesperson from whom the item was purchased. **DO NOT CONTACT INDUSTRIAL FIBER OPTICS.**

Time is of the essence because damage claims submitted more than five days after delivery may not be honored. If shipping damage has occurred during shipment, please do the following:

- Make a note of the carrier comscattering tanky, the name of the carrier employee, the date and the time of the delivery.
- Keep all packing material.
- In writing, describe the nature of damage to the product.
- In cases of severe damage, do not attempt to use the product (including attaching it to a power source).
- Notify the carrier immediately of any damaged product.
- Notify the distributor from whom the purchase was made.

# *Rules for Laser Safety*

- Lasers produce a very intense beam of light. Treat them with respect. Most educational lasers have an output of less than 3 milliwatts, and will not harm the skin.
- Never look into the laser aperture while the laser is turned on! PERMANENT EYE DAMAGE COULD RESULT.
- Never stare into the oncoming beam. Never use magnifiers (such as binoculars or telescopes) to look at the beam as it travels – or when it strikes a surface.
- Never point a laser at anyone's eyes or face, no matter how far away they are.
- When using a laser in the classroom or laboratory, always use a beam stop, or project the beam to areas, which people won't enter or pass through.
- Never leave a laser unattended while it is turned on – and always unplug it when it's not actually being used.
- Remove all shiny objects from the area in which you will be working. This includes rings, watches, metal bands, tools, and glass. Reflections from the beam can be nearly as intense as the beam itself.
- Never disassemble or try to adjust the laser's internal components. Electric shock could result.