

CONNECTOR P/N	CONNECTOR TYPE	BOOT COLOR	CABLE TYPE
106002-3300	MALE MULTIMODE	BEIGE	2 FIBER DUAL LINK Ø2.8mm JACKET & 2 FIBER RIBBON Ø2.9mm JKT
106003-3300	FEMALE MULTIMODE		
106002-3310	MALE MULTIMODE	BEIGE	2 FIBER ZIPCORDER 3.5mm X 1.6mm
106003-3310	FEMALE MULTIMODE		

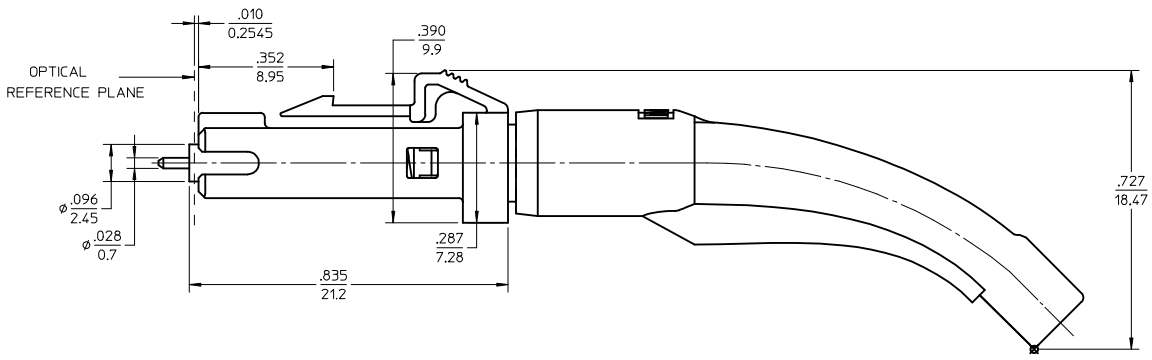

AVAILABLE CABLE TYPES

CABLE TYPE 1	CABLE TYPE 2	CABLE TYPE 3
2 FIBER DUAL LINK Ø2.8mm JACKET	2 FIBER ZIPCORDER 3.5mm X 1.6mm	2 FIBER RIBBON Ø2.9mm JACKET

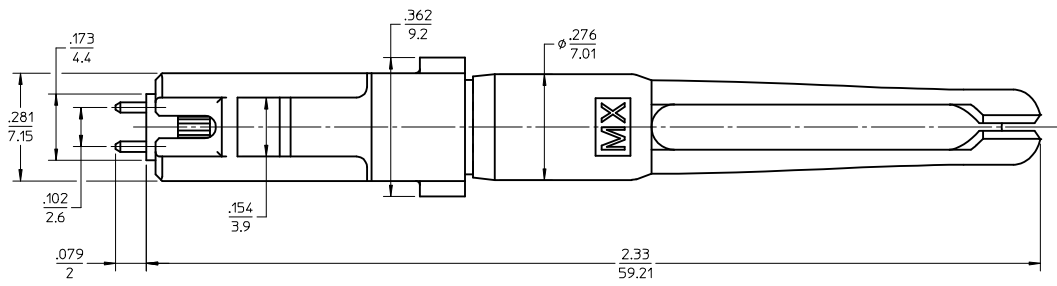
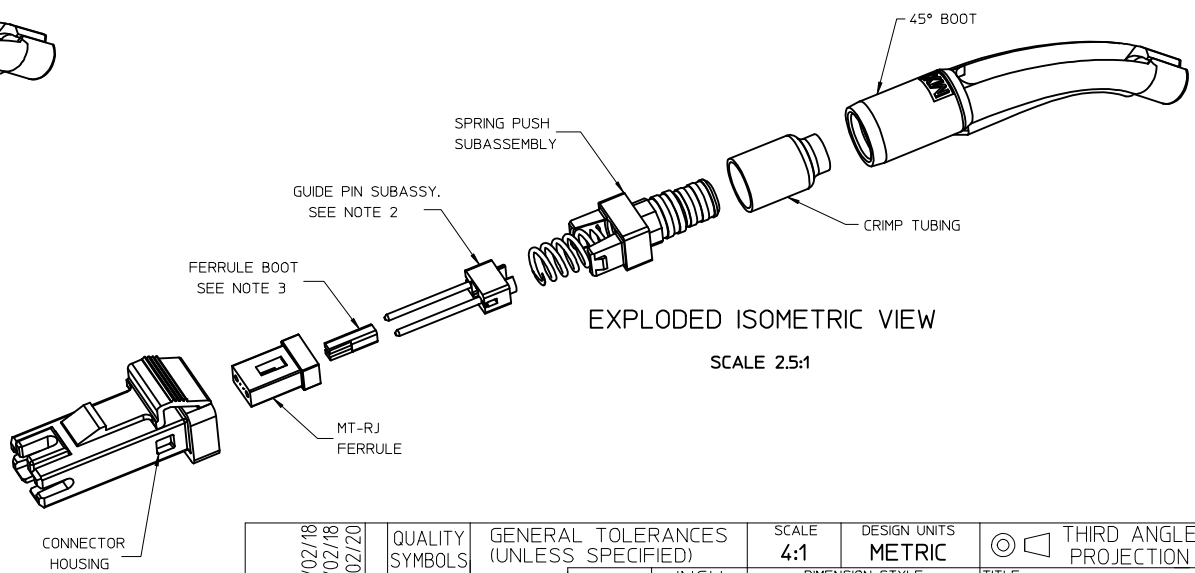
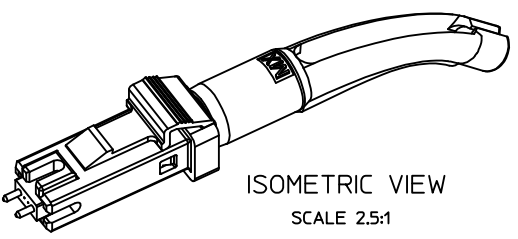

- NOTES:
- ALL DIMENSIONS ARE FOR REFERENCE ONLY.
 - MALE CONNECTOR SHOWN.
FEMALE CONNECTOR DOES NOT CONTAIN PINS.
 - CABLE TYPE 1 & 2 DO NOT REQUIRE FERRULE BOOT.

EC NO: MF2009-0410 DRWN: KPEVZNER2009/02/18 CHKD: 2009/02/18 APPR: GUMIN 2009/02/20	QUALITY SYMBOLS ▼ - 0 ∇ - 0	GENERAL TOLERANCES (UNLESS SPECIFIED)		SCALE 4:1	DESIGN UNITS METRIC	THIRD ANGLE PROJECTION	REVISE ON CAD ONLY	
		4 PLACES ± ---	± ---	DIMENSION STYLE IN/MM		TITLE		
		3 PLACES ± ---	± ---	DRAWN BY BG		DATE 07/01/2002		
		2 PLACES ± ---	± ---	CHECKED BY VCH		DATE 07/01/2002		
1 PLACE ± ---	± ---	ANGULAR ±1/2°		APPROVED BY SM		DATE 07/01/2002		
DRAFT WHERE APPLICABLE		MUST REMAIN WITHIN DIMENSIONS		APPROVED BY SM		DATE 07/01/2002		
				MATERIAL NO. SEE TABLE SD-10600X-33X0		DOCUMENT NO. 1 OF 1		
				SHEET NO. 1 OF 1		THIS DRAWING CONTAINS INFORMATION THAT IS PROPRIETARY TO MOLEX INCORPORATED AND SHOULD NOT BE USED WITHOUT WRITTEN PERMISSION		