

PART NUMBER	REV	FIRST USED
1385375-1	C	122500-1
1385375-2	C	565435-5
1385375-3	C	354500-1
3-1385375-1	C	

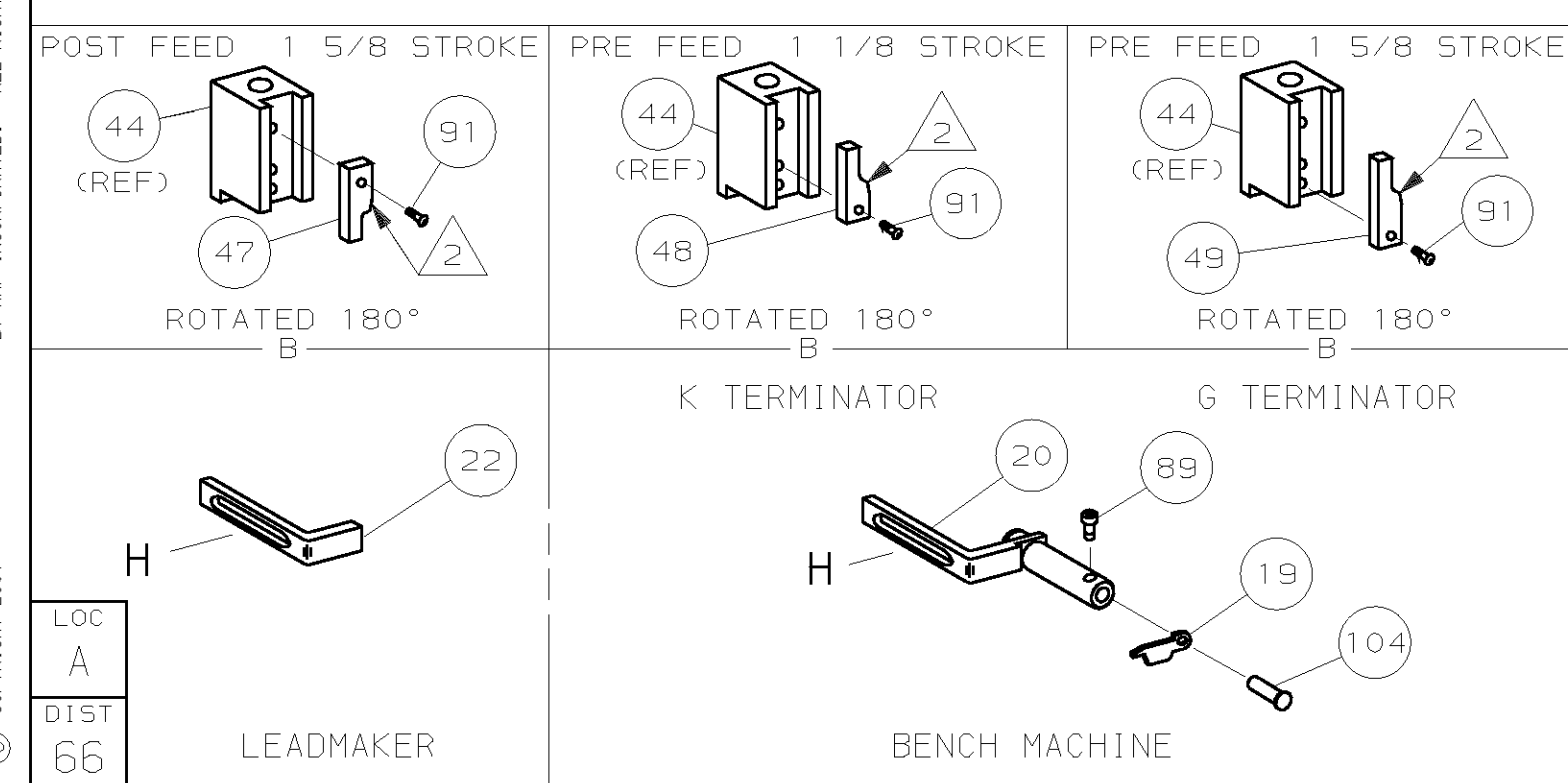
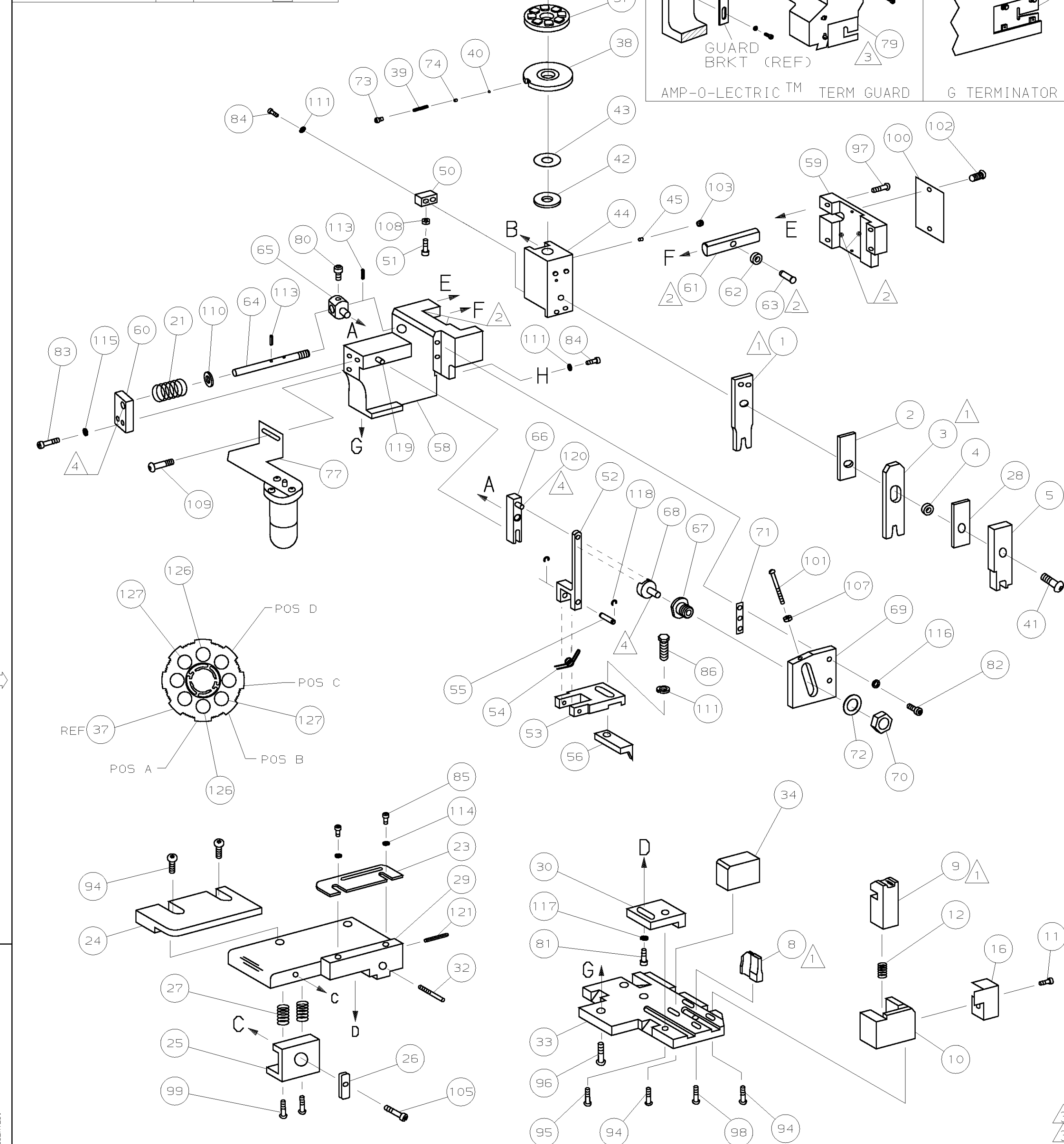

- 1 RECOMMENDED SPARE PARTS.
- 2 GREASE LIGHTLY.
- 3 GUARD MUST BE IN PLACE WHEN OPERATING APPLICATOR IN A BENCH MACHINE.
- 4 LUBRICATE DAILY USING NO. 20 MACHINE OIL.
- 5. ITEMS WITH QTY OF REF SPECIFIED (EXCEPT ITEMS 78 AND 79) ARE USED ON ITEM 46.
- 6 CONVERSION KIT TO BE USED WITH APPLICATORS 1385374 AND 1385375 ONLY.

TERMINAL NAME: PIN & SOCKET		FCI TERMINAL		AMP CRIMP SPECS	
AMP TERM PN	MFR TERM PN	PAD LTR	CRIMP HEIGHT	WIRE SIZE	
1572050	SC20M-196	A	.037-.043 [0.94-1.09mm]	20	
		B	.037-.042 [0.94-1.07mm]	22	
		C	NOT	USED	
		D	NOT	USED	
CRIMP	SIZE	TYPE	RANGE		
WIRE	.062 [1.57mm]	0	22-20		
INSUL	.100 [2.54mm]	0	.072 MAX		
WIRE STRIP LENGTH	TERM APPL SPEC	FEED	APPL INSTRUCTION	SET UP GAGE	LAYOUT
.156-.172	NONE	.351	408-8040	458637-1	L2623

QTY	REQD	PER	ASSY	PARTS LIST	ITEM NO			
2	2	2	2	- C	5-354779-1	PIN, WIRE DISC (.3245)B	127	
2	2	2	2	- C	5-354779-0	PIN, WIRE DISC (.3240)A	126	
-	1	1	1	- A	986950-1	WASHER, FLAT PRECISION	125	
-	1	1	1	- A	217238-1	GENERAL INSTRUCTION PACKAGE	124	
-	1	1	1	-	4088040	SF APPL INST 408-8040	123	
-	1	1	1	- A	4-21028-0	PIN, SLT SPR(Ø.093x.75)ST GDE PL	121	
-	REF	REF	REF	- A	1-21030-1	PIN, DOWEL (Ø.187x.50)LEVER	120	
-	REF	REF	REF	- A	1-21030-6	PIN, DOWEL (Ø.187x1.25)HOUSING	119	
-	REF	REF	REF	- A	21045-3	RING, RET "C"(Ø.187)FD FING PIN	118	
-	1	1	1	- A	21024-5	WASHER, LOCK (#10)ADJ BLOCK	117	
-	REF	REF	REF	- A	21024-5	WASHER, LOCK (#10)ADJ PLATE	116	
-	REF	REF	REF	- A	21024-5	WASHER, LOCK (#10)FEED GDE ROD	115	
-	2	2	2	- A	21024-2	WASHER, LOCK (#4)FRONT STP GUIDE	114	
-	REF	REF	REF	- A	5-21028-1	PIN, SLT SPR(Ø.125x.50)ADJ ROD	113	
-	4	4	4	- A	21024-4	WASHER, LOCK (#8)STRIPPER	111	
-	REF	REF	REF	- A	21899-4	WASHER, FLAT (Ø5/16)SCREW ADJ	110	
-	-	1	-	- A	2-21002-6	SCR, BHC (10-32x.38)LUBE ASSY	109	
-	1	1	1	- A	21068-5	NUT, HEX (6-32)HOLD DOWN	108	
-	REF	REF	REF	- A	21068-5	NUT, HEX (6-32)FEED ADJ	107	
-	1	1	1	- A	22353-8	SCR, 5HLD (Ø.187x.25)DRAG LEVER	105	
-	1	1	-	- A	992031-1	PIN, CLEVIS	104	
-	1	1	1	- A	21009-2	SCR, SKT SET (1/4-20x.25 LW)RAM	103	
-	2	2	2	- A	21017-2	SCR, DRIVE (#2x.19)ID PLATE	102	
-	REF	REF	REF	- A	6-23715-5	SCR, PAN HD (6-32x1.50)FEED ADJ	101	
-	1	1	1	- B	461264-1	PLATE, IDENTIFICATION	100	
-	2	2	2	- A	3-21002-0	SCR, BHC (10-32x.88)DRAG	99	
-	1	1	1	- A	22733-8	SCR, BHC (8-32x.38 LW)ANVIL	98	
-	REF	REF	REF	- A	2-21002-9	SCR, BHC (10-32x.75)CAP	97	
-	REF	REF	REF	- A	2-22733-8	SCR, BHC (1/4-20x.62)HOUSING	96	
-	REF	REF	REF	- A	2-21002-7	SCR, BHC (10-32x.50)SG ADJ BLOCK	95	
-	6	6	6	- A	2-21002-2	SCR, BHC (8-32x.50)TERM H DWN	94	
-	1	1	1	- A	1-21002-7	SCR, BHC (6-32x.38)CAM	91	
-	1	1	-	- A	7-21000-9	SCR, SHC (4-40x.19)STRIPPER	89	
-	1	1	1	- A	2-22603-0	SCR, HEX HD (8-32x.31)FEED FINGER	86	
-	2	2	2	- A	1-21000-3	SCR, SHC (4-40x.25)FR ST GUIDE	85	
-	3	3	3	- A	2-21000-7	SCR, SHC (8-32x.50)STRIPPER	84	
-	REF	REF	REF	- A	3-21000-7	SCR, SHC (10-32x.75)FEED ROD GD	83	
-	REF	REF	REF	- A	3-21000-6	SCR, SHC (10-32x.62)FD ADJ BLK	82	
-	1	1	1	- A	3-21000-4	SCR, SHC (10-32x.38)SG ADJ BL	81	
-	REF	REF	REF	- A	3-21000-4	SCR, SHC (10-32x.38)PIVOT BLK	80	
-	-	REF	-	- B	455749-1	GUARD, WINDOW	79	
-	REF	-	-	- B	679532-1	INSERT, GUARD	78	
-	-	1	-	- C	1-465184-0	LUBRICATOR ASSY	77	
-	1	1	1	- A	690603-1	SPRING, ASSIST	74	
-	1	1	1	- A	23030-1	SCR, SHC (6-32x.25 SL)INS DISC	73	
-	REF	REF	REF	- A	458109-1	WASHER, SPECIAL	72	
-	REF	REF	REF	- A	690517-1	SPACER	71	
-31	-3	-2	-1	U/M	DWG SIZE	PART NO	DESCRIPTION	ITEM NO

QTY	REQD	PER	ASSY	PARTS LIST	ITEM NO		
-	1	1	1	- B	22594-8	NUT, HEX (1/2-20)	70
-	REF	REF	REF	- B	240628-1	PLATE, ADJUSTMENT	69
-	REF	REF	REF	- B	240626-1	SHAFT, PIVOT	68
-	REF	REF	REF	- B	240633-1	BUSHING	67
-	REF	REF	REF	- A	455680-1	LEVER, INTERMEDIATE	66
-	REF	REF	REF	- B	240629-1	BLOCK, PIVOT	65
-	REF	REF	REF	- A	240632-2	SCREW, ADJ FEED ROD	64
-	REF	REF	REF	- B	240659-3	PIN, CAM ROLLER	63
-	REF	REF	REF	- B	240658-1	ROLLER, CAM	62
-	REF	REF	REF	- B	454398-2	ROD, FEED	61
-	REF	REF	REF	- A	454178-1	GUIDE, FEED ROD	60
-	REF	REF	REF	- C	454220-1	CAP, RAM	59
-	REF	REF	REF	- D	454485-1	HOUSING	58
-	1	1	1	- B	690542-2	PAWL, FEED	56
-	REF	REF	REF	- B	240624-1	PIN, FEED FINGER	55
-	REF	REF	REF	- B	691499-1	SPRING, FEED FINGER	54
-	REF	REF	REF	- B	690541-1	HOLDER, FEED FINGER	53
-	REF	REF	REF	- A	455679-1	LEVER, TERMINAL FEED ARM	52
-	1	1	1	- A	811242-2	BUMPER, HOLDDOWN	51
-	1	1	1	- A	690753-1	SPACER, TONKER	50
-	1	-	-	- B	690602-6	CAM, PRE-FEED 1 5/8 ST	49
-	-	1	-	- B	690602-5	CAM, PRE-FEED 1 1/8 ST	48
-	-	-	1	- B	690501-4	CAM, POST-FEED 1 5/8 ST	47
-	1	1	1	- B	459456-1	APPLICATOR, BASIC (SUBASSY)	46
-	1	1	1	- A	690191-1	PLUG, NYLON	45
-	1	1	1	- C	455673-1	RAM	44
-	1	1	1	- A	690125-1	WASHER, LAMINATED	43
-	1	1	1	- A	690124-1	WASHER, RAM	42
-	1	1	1	- A	7-21002-9	BOLT, CRIMPER (5/16x1.00)	41
-	1	1	1	- A	23241-6	BALL, STEEL	40
-	1	1	1	- A	690170-1	SPRING, COMPRESSION	39
-	1	1	1	- C	690142-1	DISC, INSULATION	38
-	1	1	1	- D	354777-1	WIRE DISC, PLASTIC	37
-	1	1	1	- A	22480-5	WASHER, SPRING	36
-	1	1	1	- B	690212-1	POST, RAM	35
-	1	1	1	- B	690786-3	SUPPORT, TERMINAL	34
-	REF	REF	REF	- D	455675-1	PLATE, BASE	33
-	1	1	1	- A	690432-3	SCREW, ADJUSTMENT	32
-	REF	REF	REF	- B	455689-1	BLOCK, STRIP GUIDE ADJ	30
-	1	1	1	- C	1-458144-2	PLATE, STRIP GUIDE	29
-	1	1	1	- C	1-455888-0	SPACER, FRONT SHEAR DEP	28
-	2	2	2	- A	1-22284-0	SPRING, DRAG	27
-	1	1	1	- B	240793-1	LEVER, DRAG RELEASE	26
-	1	1	1	- B	240792-1	DRAG, TERMINAL	25
-	1	1	1	- D	6-690504-6	GUIDE, STRIP (REAR)	24
-	1	1	1	- A	690438-1	GUIDE, STRIP (FRONT)	23
-	-	-	1	- B	690472-2	STRIPPER	22
-	REF	REF	REF	- A	4-22284-9	SPRING, FEED RETURN	21
-	1	1	-	- A	679218-1	STRIPPER WIRE STOP ASSY	20
-	1	1	-	- B	458949-1	STRIPPER	19
-	1	1	1	- B	318563-1	GUARD, CHIP, FRONT	16
-	1	1	1	- A	5-22280-0	SPRING, SHEAR	12
-	1	1	1	- B	690461-1	STOP, SHEAR	11
-	1	1	1	- C	690459-1	HOLDER, SHEAR (FRONT)	10
-	1	1	1	- C	462006-2	SHEAR, FLOAT (FRONT)	9
1	1	1	1	- C	1583292-2	ANVIL	8
-	1	1	1	- C	2-455889-0	DEPRESSOR, SHEAR (FRONT)	5
1	1	1	1	- B	238011-7	SPACER, BLOCK CRIMPER	4
1	1	1	1	- C	3-683454-1	CRIMPER, INSULATION	3
-	1	1	1	- C	455888-1	SPACER, CRIMPER	2
1	1	1	1	- C	4-459492-4	CRIMPER, WIRE	1