



中鉸股份有限公司  
東鋁五金電子（深圳）有限公司

產品規格承認書

Product Sheet for Approval

Model : AD453SPF-B

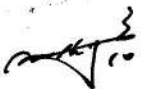
1.Product Dimension .....2  
2.Specification & Benefit.....3  
3.User Manual .....4  
4.Test Reports.....6  
5.CE Approval.....23

Doc.NO:	53141110	Audited by	Checked by		Drafted
Issued Date	2014-3-10		PM/Sales	RD	 2014.3.10

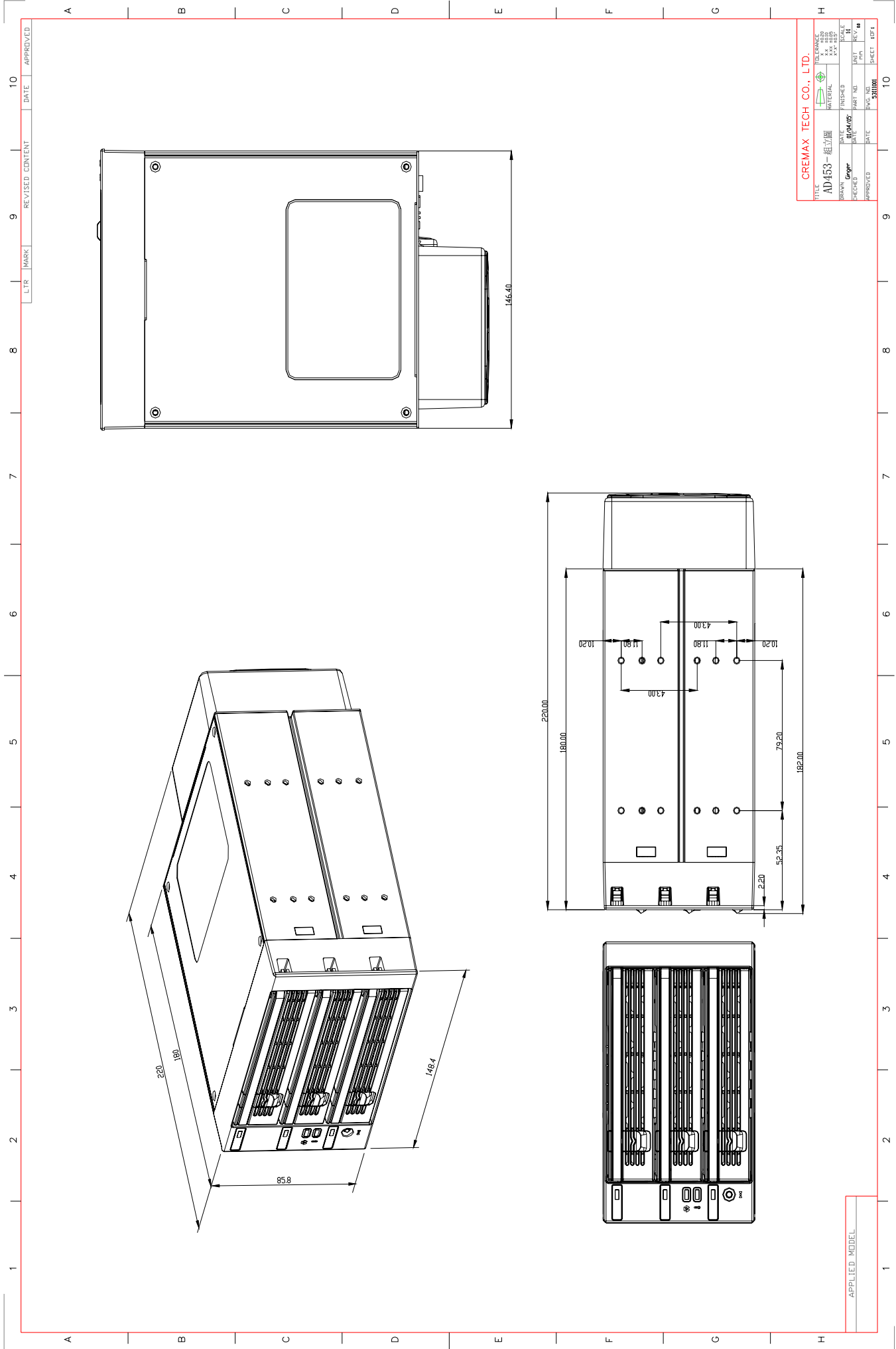

10 APPROVED DATE REVISED CONTENT MARK 9 8 7 6 5 4 3 2 1

A B C D E F G H

TITLE		CREMAX TECH CO., LTD.	
DRAWING NO.		AD453-組立圖	
MATERIAL		FINISHED	
SCALE		1:1	
DATE	APPROVED	DATE	APPROVED
2016/06/06	gogor	2016/06/06	gogor
UNIT	REV.	UNIT	REV.
mm	01	mm	01
DWG. NO.	331101	SHEET	10/1

APPLIED MODEL



### Features:

- For 2 standard 5.25" half-height expansion bay.
- Support 3 standard 3.5" & 2.5" height SATA HDD.
- Auto-eject pull in/out handle.
- Power LED & HDD Access LED indicator.
- Internal drive security, exchangeability, expandability and maintenance capabilities.
- Durable aluminum body for excellent heat dissipation with stylish outlook.
- Detachable 80mm ball bearing rear cooling fan for easy maintenance.
- Advanced drive monitoring system built internally w/ visual & audio indicators.

### Technical Specification:

<b>Model</b>	AD453SPF-B
<b>Available Colors</b>	Black Front Panel & Silver Body
<b>Drive Fit</b>	3×3.5" & 2.5" SATA Hard Drive
<b>Device Fit</b>	2 x 5.25" Device Bay
<b>Host interface</b>	3 x SATA 7-Pin
<b>Power Input</b>	2 x Molex 4PIN Power Connector
<b>Transfer Rate</b>	Up to 6Gb/sec. (Depending on Hard Drive Speed)
<b>Insert &amp; Extract connection via</b>	Direct SATA Hard Drive Connection
<b>LED Indicator</b>	Power (Green) ; HDD Access (Flashing Amber) ; Fan failure and overheat (Red)
<b>Cooling System</b>	80 x 80 x 25 mm Fan
<b>Fan Speed Control</b>	No
<b>Hot Swap</b>	Yes
<b>Material</b>	Metal and Partial plastic
<b>Package Contents</b>	Device x 1, User Manual x 1, Screws x 14
<b>Dimension (W x H x D)</b>	( w/ fan ) 220.0 x 146.0 x 86.0 mm (w/o fan) 180.0 x 146.0 x 86.0 mm

B. Select the appropriate screws to mount the 2.5" or 3.5" HDD to the corresponding screw holes on the HDD tray. Insert the HDD tray into the device.

B. 選擇需安裝的2.5吋/3.5吋硬碟專用螺絲，對應螺絲孔固定硬碟後，再將托盤放回本體內。

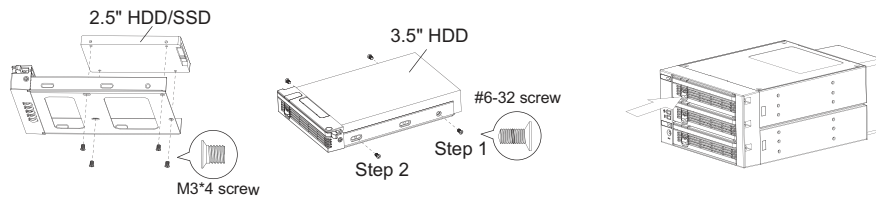

C. The Cooling Fan is removable when it is not needed.

(After removing Cooling Fan, the FAN FAIL system and alarm will not transmit any signal.)

C. 當不需要風扇時，可將風扇組件取下。（此風扇裝置移除後，同時將無FAN FAIL警示燈號/聲音提示功能）

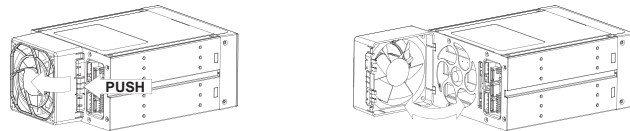

★ Both power connections must be used for proper operation of the enclosure.

★ 二個電源接頭必須同時連接供電，才能正常啟動運作。

#### Note 注釋:

1. HDD failure will indicate red only when signals are transmitted by host.  
(Please refer to HDD-fail signal)
1. 本產品之HDD故障信號來源，是經由主機(host)端提供。（相關設定請參見“硬盤故障訊號說明”）
2. The above testing conditions were obtained the surrounding temp. at 25°C.
2. 本產品相關之測試，皆以環境溫度25°C做為檢測基準溫度。
3. Any unrelated changes in the technical specification are subject to change without prior notice.
3. 本公司保留產品升級與變更之權利，如改版，恕不另行通知。
4. We will not be liable responsible for any software, hardware or other data stored within, or interfacing with our product which resulted to being damaged dysfunctional. Cremax will only be responsible to repair/service its own product.
4. 如因使用本產品進而造成其它相關設備之故障，本公司僅負擔自屬產品之修繕責任。造成其它設備毀損概不負責。
5. SATA II HDD specification has HDD ACCESS signal, but SATA I HDD does not have it.
5. SATA II HDD 規格有規範 HDD ACCESS訊號，而SATA I HDD無此規範。
6. SATA II HDD signal function design depends on the brand name/types used.
6. SATA II HDD 是否有內建 HDD ACCESS訊號功能，需參照各家硬碟製造商設計規範。
7. For any further inquiries about product application or more related product information, please linked to [www.icydock.com](http://www.icydock.com)
7. 如欲知更多產品資訊，歡迎上網瀏覽本公司網站：[www.icydock.com](http://www.icydock.com)

# AD453SPF

( 2 device bay with 3 HDD slots )  
SATA Backplane Module



User Manual  
使用說明書

2 3  
5.25" SPACE 2.5/3.5" HDD

## 1 Package indication

## 包裝說明

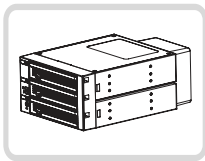

Product  
產品

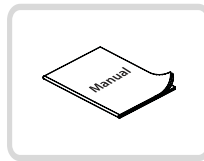

Manual  
說明書

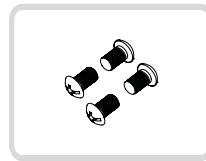

#6-32 Screws x 12 for Device  
12顆鎖機箱專用螺絲(傘頭#6-32)

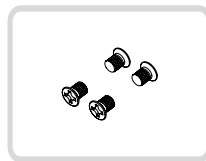

M3\*4 Screws x 12 for 2.5" HDD  
12顆鎖2.5吋硬碟專用螺絲(M3\*4)

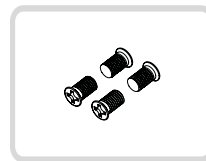

#6-32 Screws x 12 for 3.5" HDD  
12顆鎖3.5吋硬碟專用螺絲(皿頭#6-32)

## 2 Front panel's light signal instruction

## 面板燈號說明

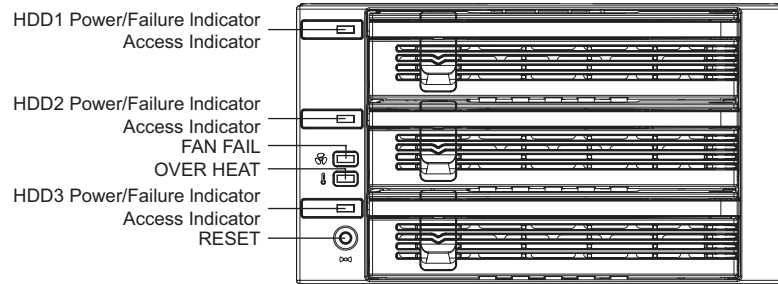

- 2.1. The Front panel's HDD signal lights are based on three colors in one.
  - 2.1.1. When HDD is attached to the tray; LED will show green light, which means power on.
  - 2.1.2. When HDD is running, LED will show orange light flashing, which means HDD is operating.
  - 2.1.3. When HDD fails, LED will show red light, which means HDD is faulty. (This signal should be provided by the HOST see 2.2)
- 2.2. HDD FAIL system
  - 2.2.1. This product can not provide the signal, unless the HOST supports this function.
  - 2.2.2. If the Host can provide HDD fail signal, connect the cable to the HOST and to the backplane HDD FAIL 1、2、3.
  - 2.2.3. When the HDD is damaged, the light will show red color.
- 2.3. Cooling Fan damaged and product overheat warning:
 

Cooling Fan's characteristic: this product is designed to be replaceable; it does not need to turn off power to replace a new one or remove it.

  - 2.3.1. When Cooling fan stops running or fail, the Fan Fail light will show red, the alarm start to buzzer; therefore push the reset button the buzzer will stop; but the light will keep in red until the Fan is removed or replaced.

- 2.3.2. If Cooling Fan is not installed, the fan failure alarm will not transmit any signal. Temperature control instructions: this product can be set at 45°C、55°C、65°C.
- 2.3.3. When the product temperature exceeds the temperature set, the light will appear in red, and the buzzer will start, and then press RESET to stop the buzzer. OVERHEAT light will keep in red, until the temperature is below the temperature setting.
- 2.1. 面板燈號為三合一三色燈設計。
  - 2.1.1. 當硬碟插入插槽時，LED顯示綠燈，表示電源開啟。
  - 2.1.2. 當硬碟運轉時，LED閃爍顯示橙燈，表示硬碟運作。
  - 2.1.3. 當有硬碟損壞時，其對應之LED顯示紅燈，表示硬碟損壞。(該訊號須由外部提供，見2.2)
- 2.2. HDD FAIL訊號輸出方式。
  - 2.2.1. 本產品無法主動提供該訊號，需配合有該項功能之主機板或控制卡。
  - 2.2.2. 再依據主機板或控制卡上之訊號輸出另以排線接至本產品背板上HDD Fail 1、2、3上。
  - 2.2.3. 當有硬碟損壞時，其對應之LED顯示紅燈，表示硬碟損壞。
- 2.3. 風扇故障及產品溫度過高警示說明：
 

風扇特點說明：該產品之風扇設計為可熱抽換式，不需關掉產品電源即可更換。

  - 2.3.1. 當風扇損壞停止轉動時，其Fan Fail燈號隨即顯示紅燈，蜂鳴器開始鳴叫，按Reset鍵，蜂鳴器停止鳴叫，但Fan Fail之燈號持續動作。須等到風扇拆下不裝或更換新風扇，始可正常使用。
  - 2.3.2. 若無安裝風扇時，其風扇故障警示無作用。

溫度設定特點說明：該產品有提供45°C、55°C、65°C 三種溫度設定功能。

  - 2.3.3. 當產品使用溫度超出設定值時，其Over Heat燈隨即顯示紅燈，蜂鳴器開始鳴叫，按Reset鍵，蜂鳴器停止鳴叫，但Over Heat之燈號持續動作。須等到溫度降到設定值以下，始可正常使用。

## 3 Back Panel Description

## 背板說明

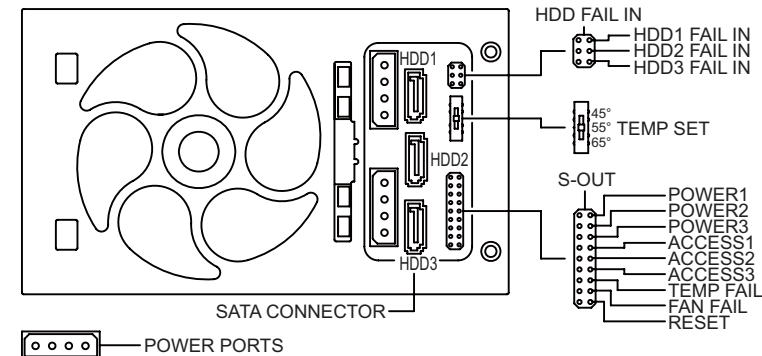

## 4 Instructions

## 操作步驟

- A. Slide the button, handle will semi-reject, then remove the tray.
- A. 下壓鎖扣，把手彈出，將托盤拉出。

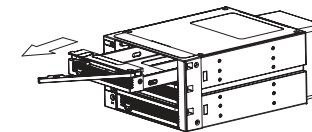
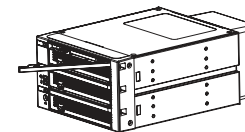
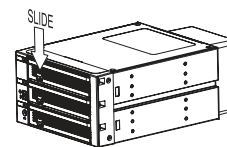

中鉸股份有限公司  
 東鋁五金電子（深圳）有限公司  
 工程  
 部  
 產品測試報告

機種：AD453SPF-B

P. C. B.：200157

PCB 版本：1.0

Doc. NO:		Audited by	Checked by		Drafted
Issusd Date			PM/Sales	RD	
Edition					

## 目錄

II. 總結摘要 .....	3
III. 儀器設備 .....	3
一、機械性能檢測 .....	4
1.1、外觀、結構檢查 .....	4
1.2、外型尺寸測量 .....	4
1.3、Connector 插拔力測試 .....	4
1.4、硬碟安裝驗證 .....	5
1.5、機箱安裝驗證 .....	5
1.6、震動測試 .....	5
1.7、跌落測試 .....	6
1.8、溫升測試 .....	9
二、環境特性測試 .....	10
2.1、操作環境溫度測試 .....	10
2.2、儲存環境測試 .....	10
三、電子功能測試 .....	11
3.1、燈號顯示功能測試 .....	11
3.2、Hot Swap 功能測試 .....	11
3.3、S. M. A. R. T. 功能測試 .....	12
3.4、速率測試 .....	13
3.5、大容量資料拷貝測試 .....	15
3.6、產品耗電量測試 .....	16
3.7、休眠/睡眠功能測試 .....	16
3.8、傳輸穩定性測試 .....	16
3.9、硬盤 & OS 相容性測試 .....	17

# I. 总结摘要

说明:

Pass : 测试全部通过则判定为Pass

NG : 测试有一项异常则判定为NG

Limitation: 测试结果无关产品安全性、稳定性或搭配性问题，並可有条件接受则判定为Limitation

Skip : 因测试环境或仪器限制无法测试，则判定为Skip

N/A : 由于测试机硬件限制或硬件无该项功能，则判定为N/A

## 各项测试结果

		验证项目	检查结果	说明
机械性能测试	1.1	外观, 结构检查	Pass	
	1.2	外型尺寸检查	Pass	
	1.3	Connector 插拔力测试	Pass	
	1.4	硬碟安裝驗證	Pass	
	1.5	震動测试	Pass	
	1.6	跌落测试	Pass	
	1.7	温升测试	Pass	
环境特性测试	2.1	操作环境温度测试	Pass	
	2.2	储存环境温度测试	Pass	
电子功能测试	3.1	灯号显示功能测试	Pass	
	3.2	HOT swap 功能测试	Pass	
	3.3	S.M.A.R.T.功能测试	Pass	
	3.4	速率测试	Pass	
	3.5	大容量资料拷贝测试	Pass	
	3.6	产品耗电量测试	Pass	
	3.7	休眠/睡眠功能测试	Pass	
	3.8	传输稳定性测试	Pass	
	3.9	硬盘 & OS 相容性测试	Pass	

Testing Product	AD453SPF-B	PCB : 200157	Rev : 1.0
-----------------	------------	--------------	-----------



## II. 仪器设备

### 电脑配置

PC1	Motherboard	ASUS P8P67Deluxe (Intel P67 Chipset / BIOS 版本号: V1502)
	CPU	Intel® Core (TM) i3-2100 CPU @3.10GHz
	Memory	Kingston DDR3-1333MHz, 2GB
	Hard Disk	WDC WD3200AAJS (320GB) 7200RPM, SATA II HDD *1 pcs
		Seagate ST250318AS (250GB)7200RPM,SATA II HDD *1 pcs
	POWER SUPPLY	Great Wall BTX-400SEL-P4 ( ATX12V 2.31 / 300W) *1 pcs
	Operating System	Microsoft Windows 7 Ultimate 32bit Microsoft Windows XP Ultimate 32bit
PC2	Motherboard	ASUS P8Z77-V PRO THUNDERBOLT
	CPU	INTEL I5-3470 3.2GHZ
	Memory	DDR3-1GB
	HDD	ST320LM001 (320GB) 5400RPM
	POWER SUPPLY	长城 (GreatWall) GW-6000 (80+) 500W
	Operating System	Microsoft Windows 8 Ultimate 32bit Microsoft Windows 7 Ultimate 64bit

### 测试软件

Testing software	速率测试软件	HD Tach V3.0.1.0 ; CrystalDiskmark .3.0
	SMART 测试软件	CrystalDiskInfo4.0.0 Dev4
	文件复制软件	Fast copy Ver2.06
	烧机测试软件	BurnInTest V6.0 Pro

## 一、 机械性能检测

### 1.1、 外观、结构检查

项次	检查项目	记录	结果	备注
1	本體	1. 材質檢查 OK 2. 本體檢查（無明顯變形，裂痕，色差，毛刺，斑點） OK 3. 邊緣部位無卡手/刮手的凸起物 OK 4. 本體防刮面顏色與周圍顏色一樣 OK	PASS	
2	PCB 與本體裝配	1. 固定 PCBA 螺絲孔位置 OK 2. 零件限高 OK	PASS	

### 1.2、 外型尺寸測量(單位：mm 毫米)

樣品	寬	高	深	结果
AD453SPF-B	146.0	86.0	220.0	PASS

### 1.3、 Connector 插拔力测试

	插入力	拔出力	结果
SATA 7 + 15 Pin	32N	19N	PASS
判断标准: SATA 7 + 15 Pin 最大插入力:35N; 最小拔出力:10N			

### 1.4、 硬碟安裝驗證

測試機殼: 硬碟 1 (Seagate ST3000DM001)		硬碟 2 (Western Digital WD10EZRS)	
硬碟 3 (HITACHI HTS541010A9E680)		硬碟 4 (Crucial M5-CT120M500SSD1)	
	插入	拔出	结果
硬碟插槽 1	正常	正常	PASS
硬碟插槽 2	正常	正常	PASS
硬碟插槽 3	正常	正常	PASS

### 1.5、 機箱安裝驗證

測試機殼：機殼 1 (廠牌 型號)			
	插入	拔出	結果
機殼 1	正常	正常	PASS

機殼 1 安裝圖



### 1.6、 振動測試

測試儀器：模拟汽车运输试验机	頻率範圍：5H z 震動線速：1.1RPS 震動轉速：280PRM 震動波形：正弦波 (X、Y 軸) 震動軸向：迴轉震動 振動時間：60Min			
	产品外观	电子性能	包材检查	测试结果
AD453SPF-B	OK	OK	OK	Pass
振动方式如下：				

Engineering Director :

6 Engineer :

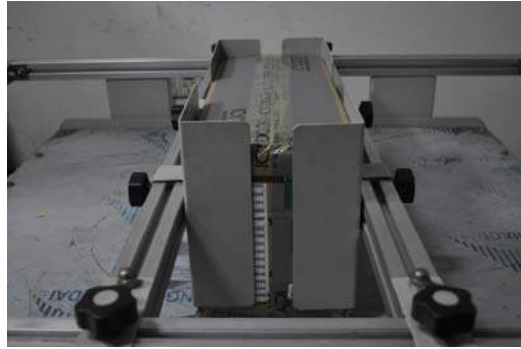

### 1.7、 跌落测试

测试仪器：模拟汽车运输试验机		跌落方式：一次尖角、三次邊、六次面 跌落次數：10 次 跌落高度：762 mm		
	产品外观	电子性能	包材检查	测试结果
AD453SPF-B	OK	OK	OK	Pass

跌落方式如下：



包装的角



包装的短边



包装的次上边



包装的长边



包装的第一面（下面）



包装的第二面（上面）



包装的第三面（反面）



包装的第四面（正面）



包装的第五面（右面）



包装的第六面（左面）

## 1.8、溫升測試

測試儀器：4 通道溫度紀錄儀

測試硬盤：HDD1 Western Digital WD10EZRS 7200RPM

HDD2 Western Digital WD20EZRS 7200RPM

HDD3 Western Digital WD10EZRS 7200RPM

Test Time		20min	40min	60min	80min	100min	120min	140min	160min
Room		25.9	26.0	26.0	25.9	25.7	25.8	26.0	25.8
HDD1	溫度計實測溫度	29.5	31.8	32.3	32.0	32.1	32.2	31.9	31.8
	SMART 監測溫度	31.0	33.0	35.0	35.0	35.0	35.0	35.0	35.0
HDD2	溫度計實測溫度	30.6	31.2	32.1	32.0	32.1	32.3	32.0	31.9
	SMART 監測溫度	31.0	32.0	33.0	33.0	33.0	33.0	33.0	33.0
HDD3	溫度計實測溫度	30.8	32.1	33.3	33.2	33.3	33.3	33.1	33.0
	SMART 監測溫度	31.0	33.0	34.0	34.0	34.0	34.0	34.0	34.0

環境溫度與硬碟溫度對照曲線表

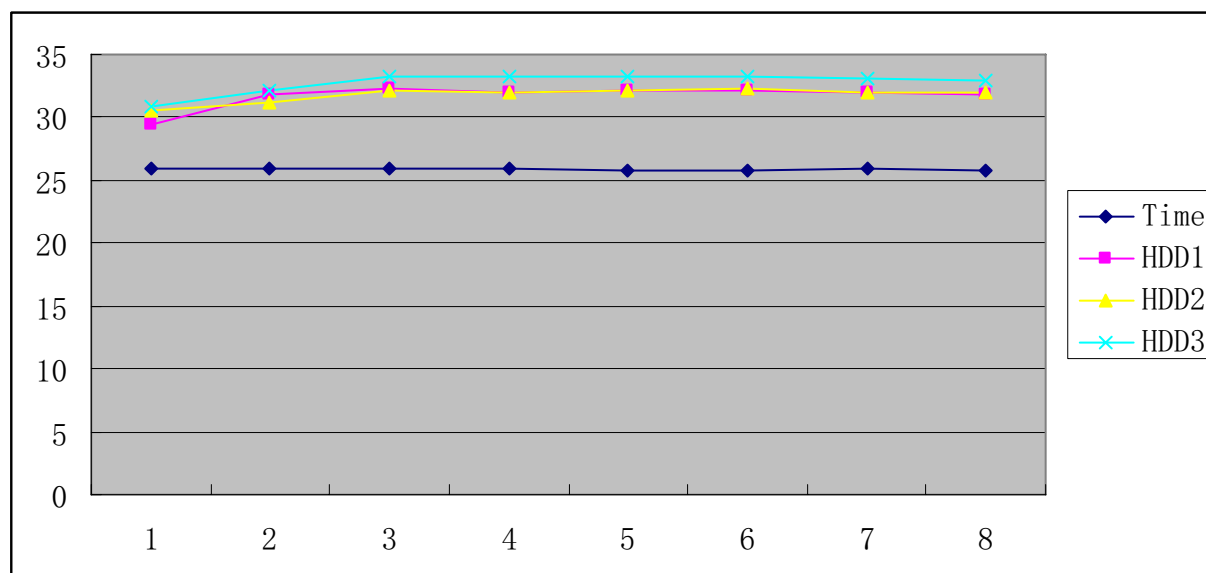

## 二、 环境特性测试

### 2.1、 操作环境温度测试

测试仪器：高低温试验箱 测试硬盘：WD WD2002FAEX		测试参数 测试温度：60℃ 测试时间：6H		
	产品外观	电子性能		Result
AD453SPF-B	正常	正常		PASS
测试方法：将产品放入试验箱中，并运行产品，在中间过程中，产品能过正常运行，并且不会出现掉盘的情况。				

### 2.2、 存储环境测试

#### I：高温存储环境测试

测试仪器：高低温试验箱		测试参数 测试温度：70℃ 测试时间：6H		
	产品外观	包材	电子性能	Result
AD453SPF-B	正常	正常	正常	PASS
测试方法：将完整的产品放入试验箱，试验结束后，产品的外观与包材不能有任何的损坏，电子功能测试不能出现问题。				

#### II：低温存储环境测试

测试仪器：高低温试验箱		测试参数 测试温度：-35℃ 测试时间：6H		
	产品外观	包材	电子性能	Result
AD453SPF-B	正常	正常	正常	PASS
测试方法：将完整的产品放入试验箱，试验结束后，产品的外观与包材不能有任何的损坏，电子功能测试不能出现问题。				

### 三、 电子功能测试

#### 3.1、 灯号显示功能测试

##### I. 工作状态

	AD453SPF-B	Result
電源開啓，偵測硬碟	橙灯閃爍	Pass
電源開啓，硬碟讀寫訊號	橙灯閃爍	Pass
電源開啓，硬碟閒置	綠燈恒亮	Pass
電源開啓且電腦進入休眠	無燈號	Pass

##### II. 颜色、亮度检查

	Power LED (綠燈)		Activity LED (橙燈)		Result
	顏色	亮度	顏色	亮度	
AD453SPF-B	正常	正常	正常	正常	PASS

注： 不同硬盘厂商的硬盘的 LED 外送信号会有所不同，有些硬盘可能不支持本产品的 LED 指示灯灯号

#### 3.2、 Hot swap 功能测试

	Host	Device	Result
SATA	正常	正常	PASS

注：在不关闭 PC 和电源的情况下，能够正常的插拔硬盘，并且硬盘能过正常的运行



## 3.3、S.M.A.R.T.功能测试

	CrystalDiskInfo4. 0. 0 Dev4	Result
AD453SPF-B	PASS	PASS



CrystalDiskInfo 4.0.0 Dev4

文件(F) 编辑(E) 功能(U) 主题(T) 磁盘(D) 帮助(H) 界面语言(L)(Language)

警告 34 °C  
良好 33 °C  
C: D: E:

**WDC WD2002FAEX-007BA0 2000.3 GB**

健康状态: **良好**

温度: **33 °C**

固件	05.01D05	缓存大小	未知
序列号	WD-WMAY01402024	NV缓存大小	---
接口	Serial ATA	转动率	未知
传输模式	SATA/600	使用周期	2564 周期
卷标	E:	使用时间	< 9:18:10:00
标准	ATA8-ACS   ---		
支持的特征	S.M.A.R.T., 48bit LBA, RPMs, AAM, NCQ, TRIM		

ID	属性名称	当前	最差	临界	Raw值
01	累计数据读取错误率	200	200	51	000000000001
03	马达旋转同步时间	253	253	21	000000001D6D
04	启动/停止次数	98	98	0	00000000AFD
05	重新分配扇区数	196	196	140	0000000001C
07	寻道出错率	200	200	0	000000000000
09	累计通电时间	99	99	0	00000000396
0A	旋转重试数	100	100	0	000000000000
0B	重新校准回块找回	100	100	0	000000000000
0C	设备通电周期	98	98	0	00000000A04
0D	断电找回次数	197	197	0	00000000961
C1	载入/卸载周期数	200	200	0	00000000198
C2	温度	119	68	0	00000000021
C4	重新分配事件数	198	198	0	00000000002
C5	当前挂起扇区数	200	200	0	000000000000
C6	无法修正的扇区总数	200	200	0	000000000000
C7	UltraDMA CRC错误总数	200	107	0	000000024EE
C8	写入错误评估	200	200	0	000000000000

3. 4、 速率测试

	HD Tach (3.0.1.0)		CrystaIDiskmark. 3.0		UNIT	Result
	Burst Speed	Average read	Read (Sep)	Write (Sep)		
WD2002FAEX-BOT	350.8	123.9	152.0	152.0	MB/S	Pass
WD2002FAEX-HDD1	250.1	123.9	152.1	149.3	MB/S	
WD2002FAEX-HDD2	407.1	124.0	152.1	148.9	MB/S	Pass
WD2002FAEX-HDD3	352.8	132.9	151.1	148.6	MB/S	

注： 1. 速率测试参考硬盘裸测的速率判断。  
 2. 速率测试截图下圖

WD2002FAEX-BOT

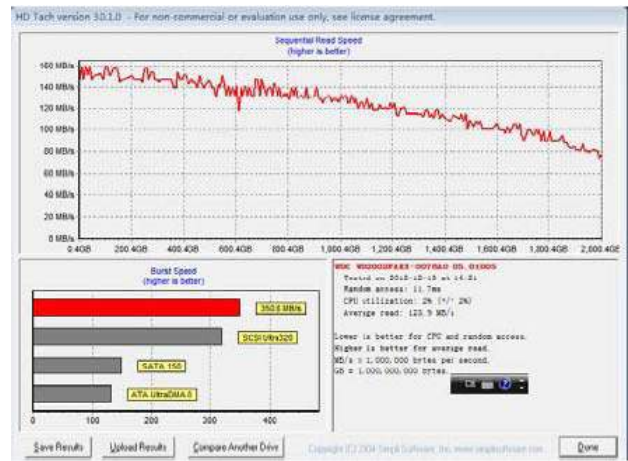

HD Tach (3.0.1.0) Test-BOT

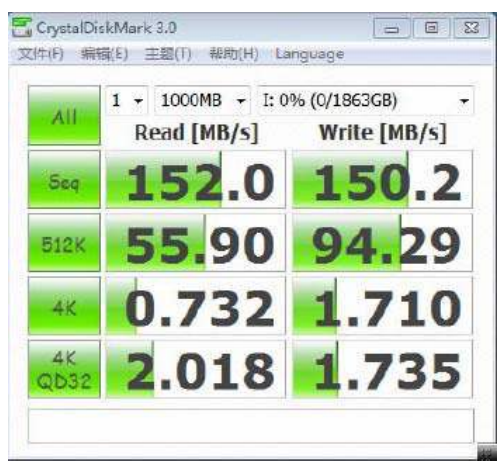

CrystalDiskmark. 3.0 Test - BOT

WD2002FAEX-HDD1

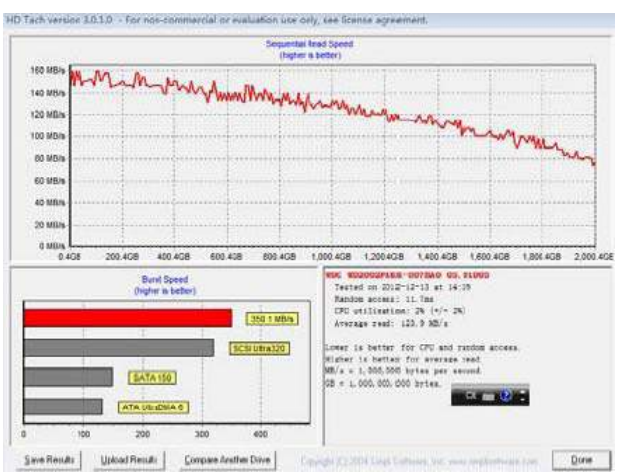

HD Tach (3.0.1.0) Test-HDD1



CrystalDiskmark. 3.0 Test - HDD1

WD2002FAEX-HDD2

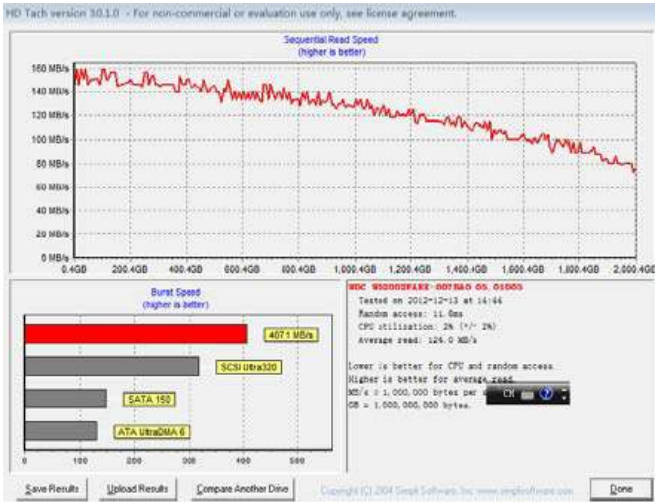

HD Tach (3.0.1.0) Test-HDD2



CrystalDiskmark. 3.0 Test - HDD2

WD2002FAEX-HDD3

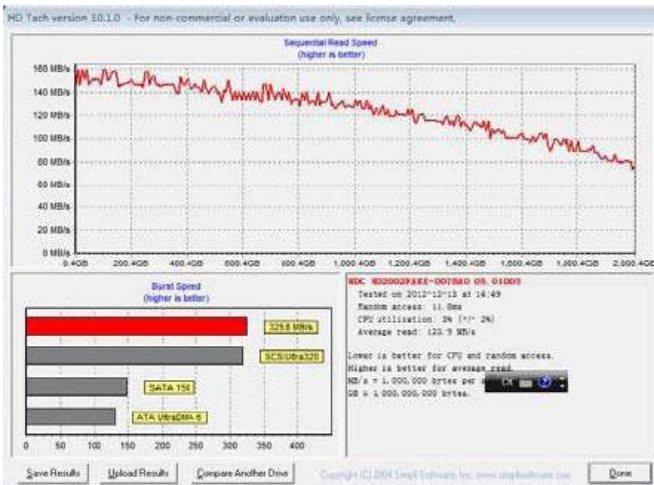

HD Tach (3.0.1.0) Test-HDD3

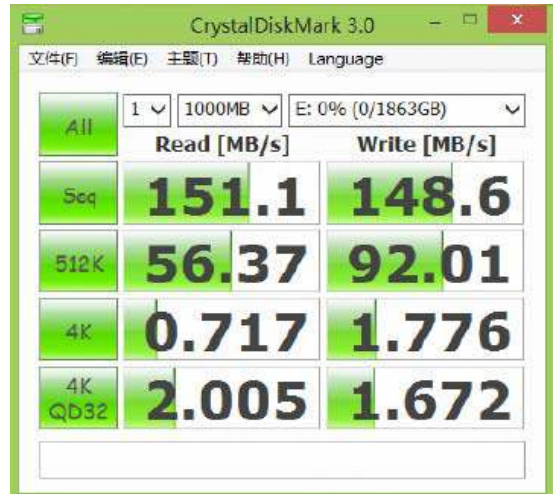

CrystalDiskmark. 3.0 Test - HDD3

### 3.5、 大容量资料拷贝测试

	ERROR	Result
AD453SPF-B	None	PASS

注：大容量资料拷贝测试截图下图

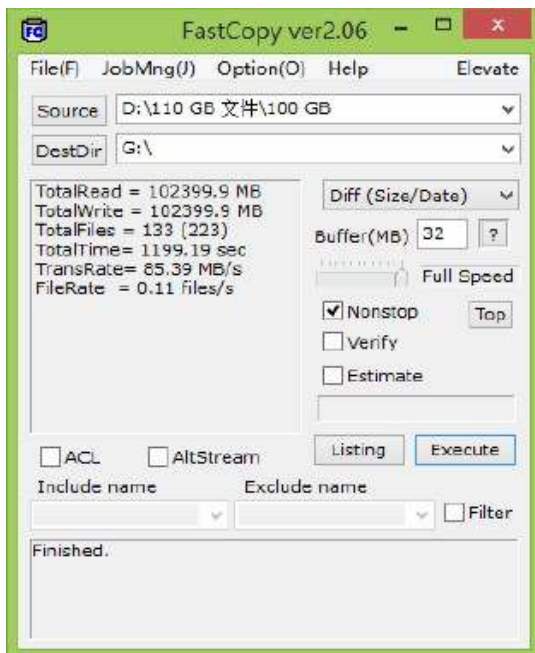

Copy-BOT

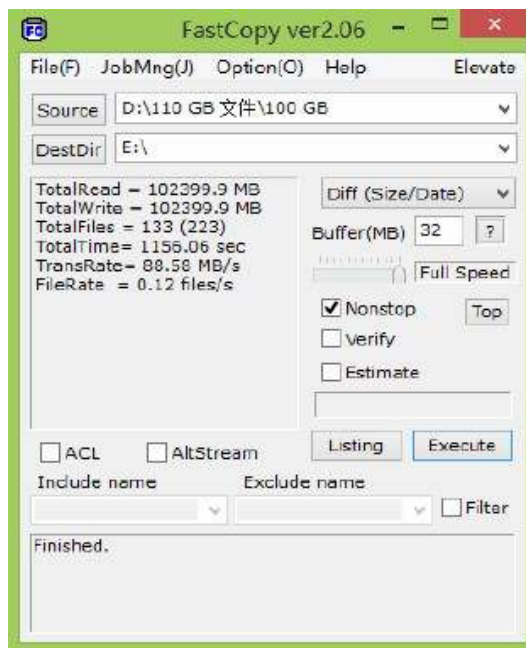

Copy-HDD1

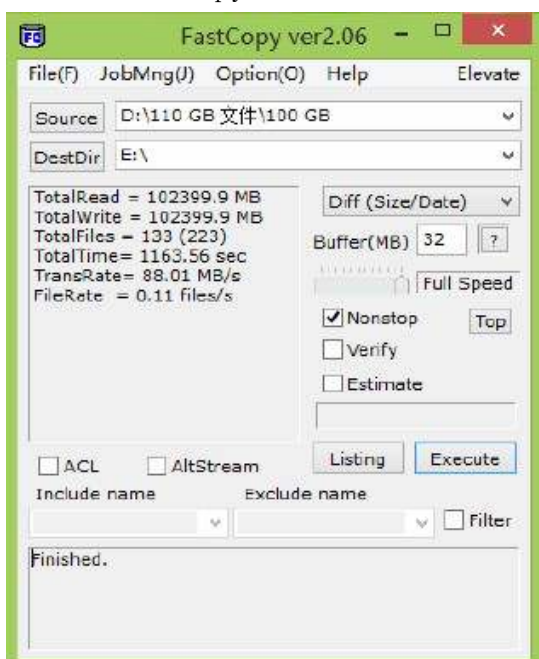

Copy-HDD2

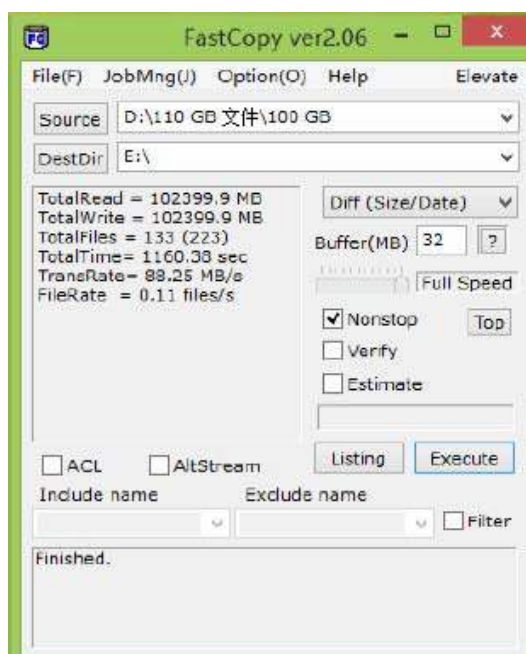

Copy-HDD3

### 3.6、 產品耗電量測試

狀態	耗費功率	Result
空機運轉 (未安裝硬碟情況下)	1.2 W	PASS
硬碟啓動	44.8 W	PASS
硬碟閒置	18.6 W	PASS
產品休眠 (電腦休眠情況下)	0W	PASS
測試硬碟： Seagate ST32000542AS 7200rpm Seagate ST30000DM001 7200rpm Western Digital WD20EZRX 7200rpm		

### 3.7、 休眠/睡眠功能測試

	支援休眠	休眠時資料傳輸情況	Result
Win7-64 位	OK	正常	PASS
Win7-32 位	OK	正常	PASS
Win8-64 位	OK	正常	PASS
备注：电脑休眠后，产品应与电脑同步休眠，待电脑唤醒后，产品应执行电脑休眠前的动作。			

### 3.8、 传输稳定性测试

测试软件：BurnInTest V6.0 Pro		测试时间：12H
测试硬盘：ST320LT012		
	ERROR	Result
SATA	None	PASS

### 3.9、 硬盘 & OS 相容性测试

厂牌	容量	型号	接口类型	OS	结果	备注
Seagate	3000GB	ST3000DM001	SATA III	Win8	PASS	3.5 寸机械硬盘
				Win7		
				Win xp		
Seagate	2000GB	ST32000641AS	SATA III	Win8	PASS	
				Win7		
				Win xp		
WD	250GB	WD2500HHTZ	SATA III	Win8	PASS	
				Win7		
				Win xp		
WD	3000GB	WD30EZRS	SATA III	Win8	PASS	
				Win7		
				Win xp		
WD	2000GB	WD2002FAEX	SATA III	Win8	PASS	
				Win7		
				Win xp		
WD	2000GB	WD20EZRS	SATA II	Win8	PASS	
				Win7		
				Win xp		
Seagate	1500GB	ST32000341AS	SATA II	Win8	PASS	
				Win7		
				Win xp		
Hitachi	250GB	HDP725025GLA380	SATA II	Win8	PASS	
				Win7		
				Win xp		
Maxtor	80GB	SMT380215AS	SATA II	Win8	PASS	
				Win7		
				Win xp		



HomeTek Technology Inc.

ADDRESS: No. 67-9, Shir Men Road, Tu Cheng City, Taipei Hsien, Taiwan, R. O. C.
PHONE : 886-2-22608375 FAX : 886-2-22748013
E - mail : hometek@ms15.hinet.net

CERTIFICATE OF COMPLIANCE

EUT : Multiple bay internal removable HDD module
MODEL NO. : MB453SPF-X, MB454SPF-X, MB455SPF-X (X = A~Z)
Receipt Date : 06/09/2005 Final Test Date: 06/15/2005
REPORT # : EB4F020
APPLICANT : CREMAX TECH. CO., LTD.
ADDRESS : 2F, No. 18, Lane 609, Sec. 5, Chung-Hsin Rd., San-Chung City, Taipei, Taiwan, R. O. C.

Measurement procedure used:

- EMI: EN 55022 Class B (1998) + A1 (2000) + A2 (2003), EN 61000-3-2 (2000), EN 61000-3-3 (1995) + A1 (2001)
EMS: EN 55024 (1998) + A1 (2001) + A2 (2003):
IEC 61000-4-2 (2001), IEC 61000-4-3 (2002), IEC 61000-4-4 (2004), IEC 61000-4-5 (2001), IEC 61000-4-6 (2003) + A1 (2004), IEC 61000-4-8 (2001), IEC 61000-4-11 (2004)

We hereby show that:

The measurements shown in this test report were made in accordance with the procedures given in EUROPEAN COUNCIL DIRECTIVE 89/336/EEC, and the energy emitted by the equipment was found to be within the limits applicable.

This test result of this report applies to above tested sample only.

This test report shall not be reproduce in part without written approval of HomeTek Technology Inc.

PREPARED BY : MING YU LI DATE : 6/20/2005

CHECK BY : ALAIN LIN / Director DATE : 6/20/2005

APPROVED BY : TOMMY RAU / Manager DATE : 6/20/2005