

THIS DRAWING IS UNPUBLISHED. RELEASED FOR PUBLICATION  
 © COPYRIGHT BY TYCO ELECTRONICS CORPORATION. ALL RIGHTS RESERVED.

LOC	DIST	REVISIONS					
AD	00	P	LTR	DESCRIPTION	DATE	DWN	APVD
		A		DRAWING CREATED	05DEC05	MKC	-

MATERIALS		
COMPONENT NAME	BASE MATERIAL	FINISH
HOUSING	PBT, UL94 V-0, GRAY	
FRAME	BRASS	NICKEL
LEVER	BRASS	NICKEL
MOVABLE CONTACT	PHOSPHOR BRONZE	GOLD OVER NICKEL
TERMINAL (CONTACT AREA)	PHOSPHOR BRONZE	GOLD OVER NICKEL
TERMINAL (SOLDER AREA)	PHOSPHOR BRONZE	GOLD OVER NICKEL

NOTES:

1. TERMINAL NUMBERS ARE FOR REFERENCE ONLY AND DO NOT APPEAR ON SWITCHES.
2. ALL MATERIALS AND FINISHES SHALL COMPLY WITH EU DIRECTIVE 2003/95/EC OF 27JAN2003 (ROHS)
3. SWITCHES ARE SEALED AND ABLE TO WITHSTAND SOLDER WASH OPERATION.

SPECIFICATIONS	
CURRENT RATING, MAX.	50mA @ 48 VDC OR PEAK AC (2.4VA)
CURRENT RATING, MIN.	1µA @ 20 VDC OR PEAK AC (.02VA)
TERMINATION RESISTANCE	50 MILLIOHMS MAX AT 1.5mA 200µVAC
INSULATION RESISTANCE	500 MEGOHMS MIN @ 250 VDC
DIELECTRIC WITHSTANDING VOLTAGE	500 VAC FOR 1 MINUTE
OPERATING TEMPERATURE	-20°C to +85°C
STORAGE TEMPERATURE	-40°C to +85°C
ELECTRICAL LIFE	
50mA @ 48 VDC OR PEAK AC	10,000 CYCLES
1µA @ 20 VDC OR PEAK AC	50,000 CYCLES (MAINTAINED), 30,000 CYCLES (MOMENTARY)
.4VA MAX @ 20 VDC OR PEAK AC	50,000 CYCLES (MAINTAINED), 30,000 CYCLES (MOMENTARY)

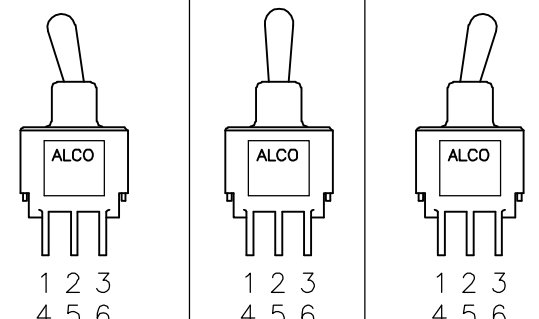
2-3, 5-6	OFF	2-1, 5-4	ON OFF ON	PC	2	2	ALCO ATE2E LOT NO.	ATE2EGPC104	1825182-5
2-3, 5-6	---	2-1, 5-4	ON ON	PC	2	2	ALCO ATE2D LOT NO.	ATE2DGPC104	1825182-4
2-3	OFF	2-1	(ON) OFF (ON)	PC	2	1	ALCO ATE1G LOT NO.	ATE1GGPC104	1825182-3
2-3	OFF	2-1	ON OFF ON	PC	2	1	ALCO ATE1E LOT NO.	ATE1EGPC104	1825182-2
2-3	---	2-1	ON ON	PC	2	1	ALCO ATE1D LOT NO.	ATE1DGPC104	1825182-1
				FUNCTION	TERMINAL	THROWS	POLES	MARKINGS	ALCO P/N TYCO P/N
TERMINALS CONNECTED									

THIS DRAWING IS A CONTROLLED DOCUMENT.

DWN MOHAN  
 CHK -  
 APVD -  
 PRODUCT SPEC -  
 APPLICATION SPEC -

05DEC05

**tyco** Tyco Electronics Corporation  
 Harrisburg, PA 17105-3608

**ABSOLUTE NOT the LATEST REVISION**

ATE SERIES TOGGLE SWITCH, PC TERMINALS, ROUND ACUTATOR, 1&2 POLE

SIZE A2 CAGE CODE 00779 DRAWING NO. C=1825182 RESTRICTED TO

WEIGHT -

CUSTOMER DRAWING SCALE 4:1 SHEET 1 of 2 REV A

THIS DRAWING IS UNPUBLISHED. RELEASED FOR PUBLICATION  
 © COPYRIGHT BY TYCO ELECTRONICS CORPORATION. ALL RIGHTS RESERVED.

LOC	DIST	REVISIONS			
P	LTR	DESCRIPTION	DATE	DWN	APVD
AD	00	SEE SHEET 1	-	-	-

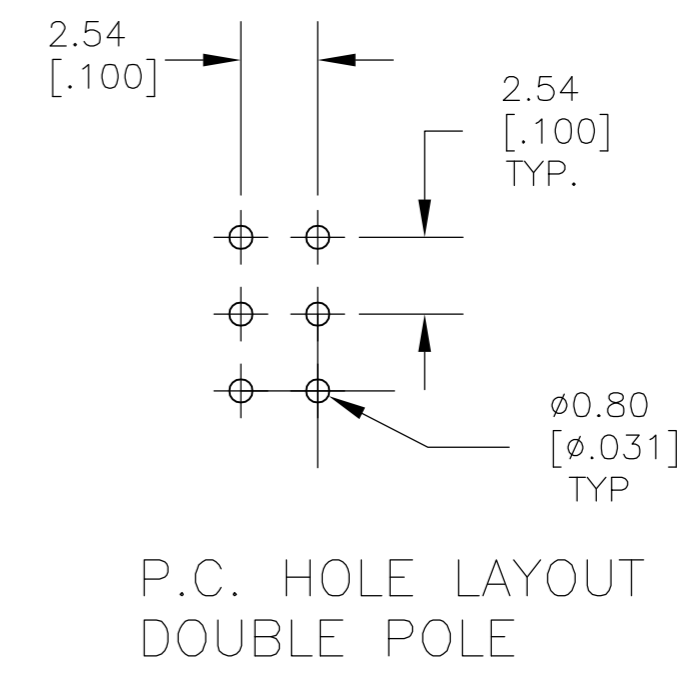
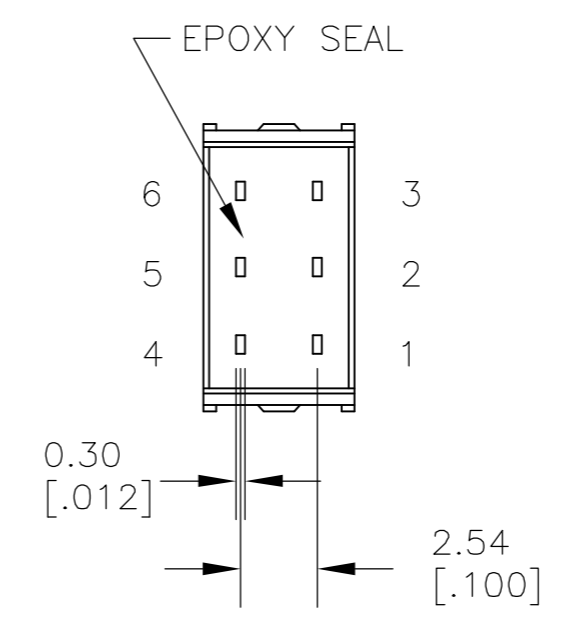
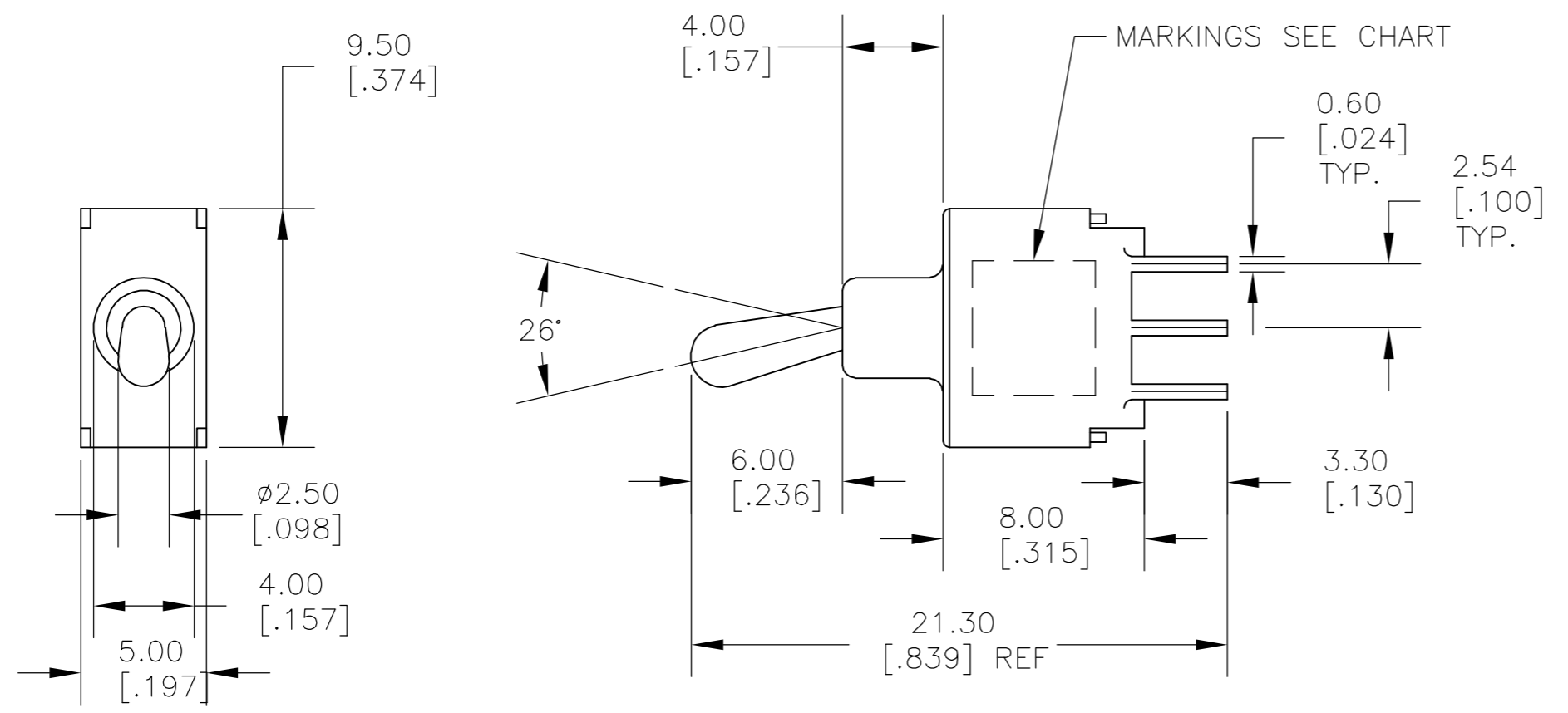
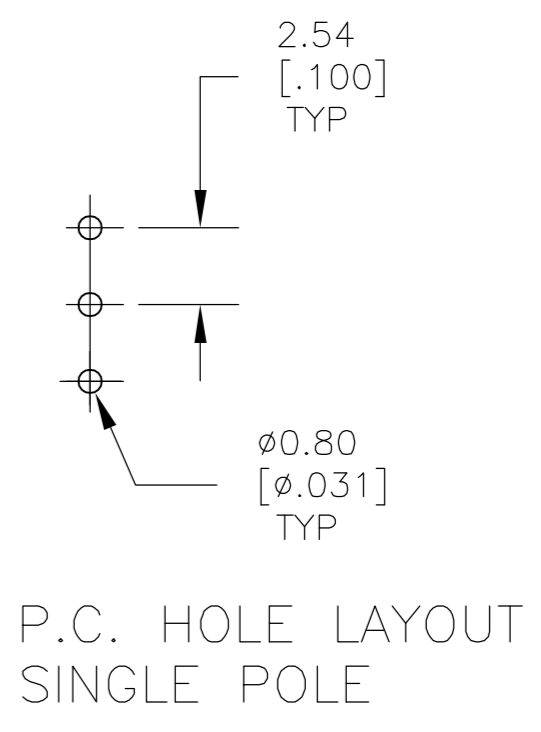
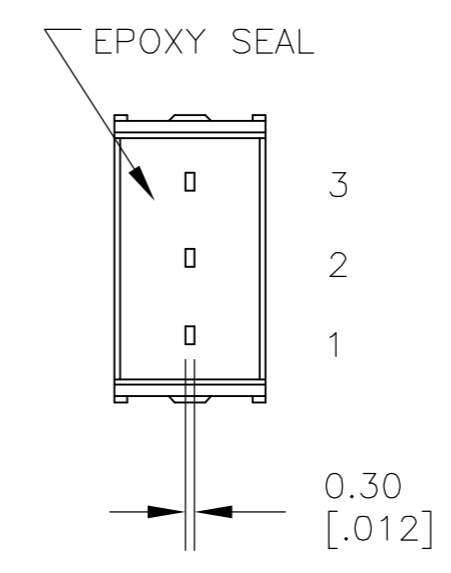
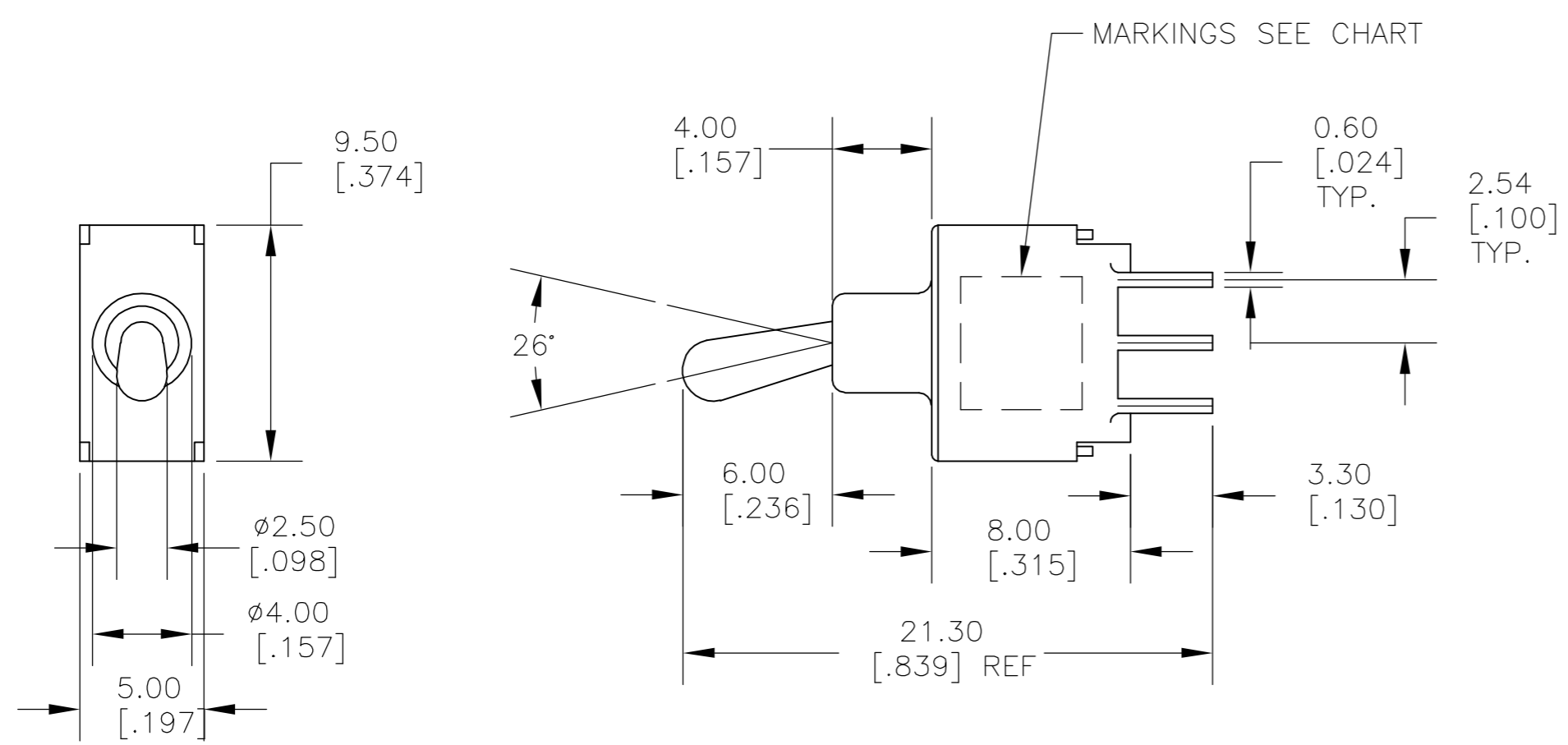

THIS DRAWING IS A CONTROLLED DOCUMENT.		DWN MOHAN	05DEC05	<b>tyco</b> Tyco Electronics Corporation	
DIMENSIONS: mm		CHK -	APVD -	Harrisburg, PA 17105-3608	
TOLERANCES UNLESS OTHERWISE SPECIFIED:		PRODUCT SPEC -	APPLICATION SPEC -	ATE SERIES TOGGLE SWITCH, PC TERMINALS, ROUND ACUTATOR, 1&2 POLE	
0 PLC ± -		WEIGHT -		SIZE A2	RESTRICTED TO -
1 PLC ± -		CUSTOMER DRAWING		CAGE CODE 00779	DRAWING NO C=1825182
2 PLC ± -		SCALE 4:1		SHEET 2 OF 2	REV A
3 PLC ± .010					
4 PLC ± -					
ANGLES ± 3°					
FINISH -					

1825182