



May. 2021 Ver.4.0  
TDK Corporation

## Multilayer Diplexer

For LTE / 5GHz

DPX Series 1.0x0.5mm [EIA 0402] TYPE

P/N: **DPX105950DT-6012A2**

## DPX105950DT-6012A2

### SHAPES AND DIMENSIONS

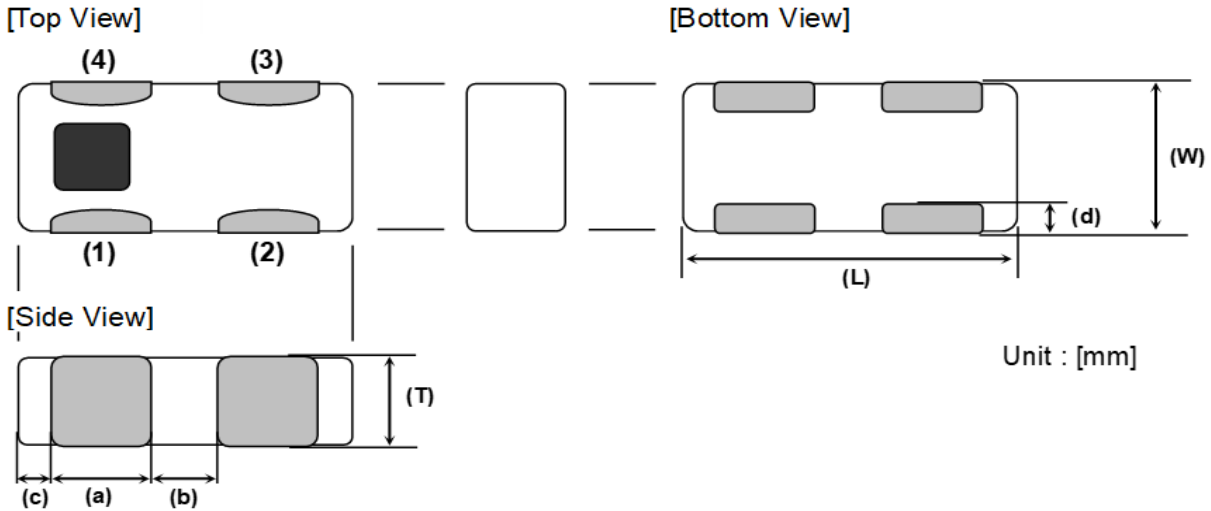

Dimensions (mm)

L	W	T	a	b	c	d
1.00	0.50	0.33	0.30	0.20	0.10	0.12
+/-0.05	+/-0.05	Max	+/-0.10	+/-0.10	+/-0.10	+/-0.07

Terminal functions

(1)	Common Port
(2)	GND
(3)	High-Band Port
(4)	Low-Band Port

### TERMINATION FINISH

Material
Sn plate

## DPX105950DT-6012A2

### ■ ELECTRICAL CHARACTERISTICS

( Measurement )

#### Low-Band

Parameter	Frequency (MHz)	TDK Spec		
		Min.	Typ.	Max.
Insertion Loss (dB)	2400 to 2500	-	0.37	0.50
Insertion Loss (dB) ( -40 to +85 °C )	2400 to 2500	-	-	0.60
Return Loss@Low-Band (dB)	2400 to 2500	10	22	-
Attenuation (dB)	4800 to 6000	23	29.0	-
	7200 to 7500	23	29.0	-
Characteristic Impedance (ohm)		50 (Nominal)		

Ta = +25+/-5°C

#### High-Band

Parameter	Frequency (MHz)	TDK Spec		
		Min.	Typ.	Max.
Insertion Loss (dB)	4900 to 5950	-	0.56	0.80
Insertion Loss (dB) ( -40 to +85 °C )	4900 to 5950	-	-	1.00
Return Loss@High-Band (dB)	4900 to 5950	10	15	-
Attenuation (dB)	30 to 2400	25	29	-
	2400 to 2500	32	41	-
	2500 to 2690	23	29	-
	9800 to 11900	20	30	-
Characteristic Impedance (ohm)		50 (Nominal)		

Ta = +25+/-5°C

## DPX105950DT-6012A2

### ■ ELECTRICAL CHARACTERISTICS

( Measurement )

#### Common

Parameter	Frequency (MHz)	TDK Spec		
		Min.	Typ.	Max.
Return Loss (dB) ( Common Port )	2400 to 2500	10	22	-
	4900 to 5950	10	15	-
Characteristic Impedance (ohm)		50 (Nominal)		

 $T_a = +25\pm 5^\circ\text{C}$ 

### ■ MAXIMUM RATINGS

Parameter		TDK Spec	Conditions
Operating temperature (°C)		-40 to +85 °C	
Storage temperature (°C)		-40 to +85 °C	
Power Handling (W) *1	Frequency (MHz)		
	Common Port	2400 to 2500	1 CW
		4900 to 5950	1 CW
	Low-Band	2400 to 2500	1 CW
	High-Band	4900 to 5950	1 CW
Human Body Model : HBM	@Each Port (V)	+/-1000	100pF / 1500ohm
Machine Model : MM	@Each Port (V)	+/-150	200pF / 0ohm
Charged Device Model : CDM	@Each Port (V)	+/-500	Humidity : 60%RH max

\*1 : Refer to 3GPP TS 38.101-1 V15.2.0

# DPX105950DT-6012A2

## FREQUENCY CHARACTERISTICS

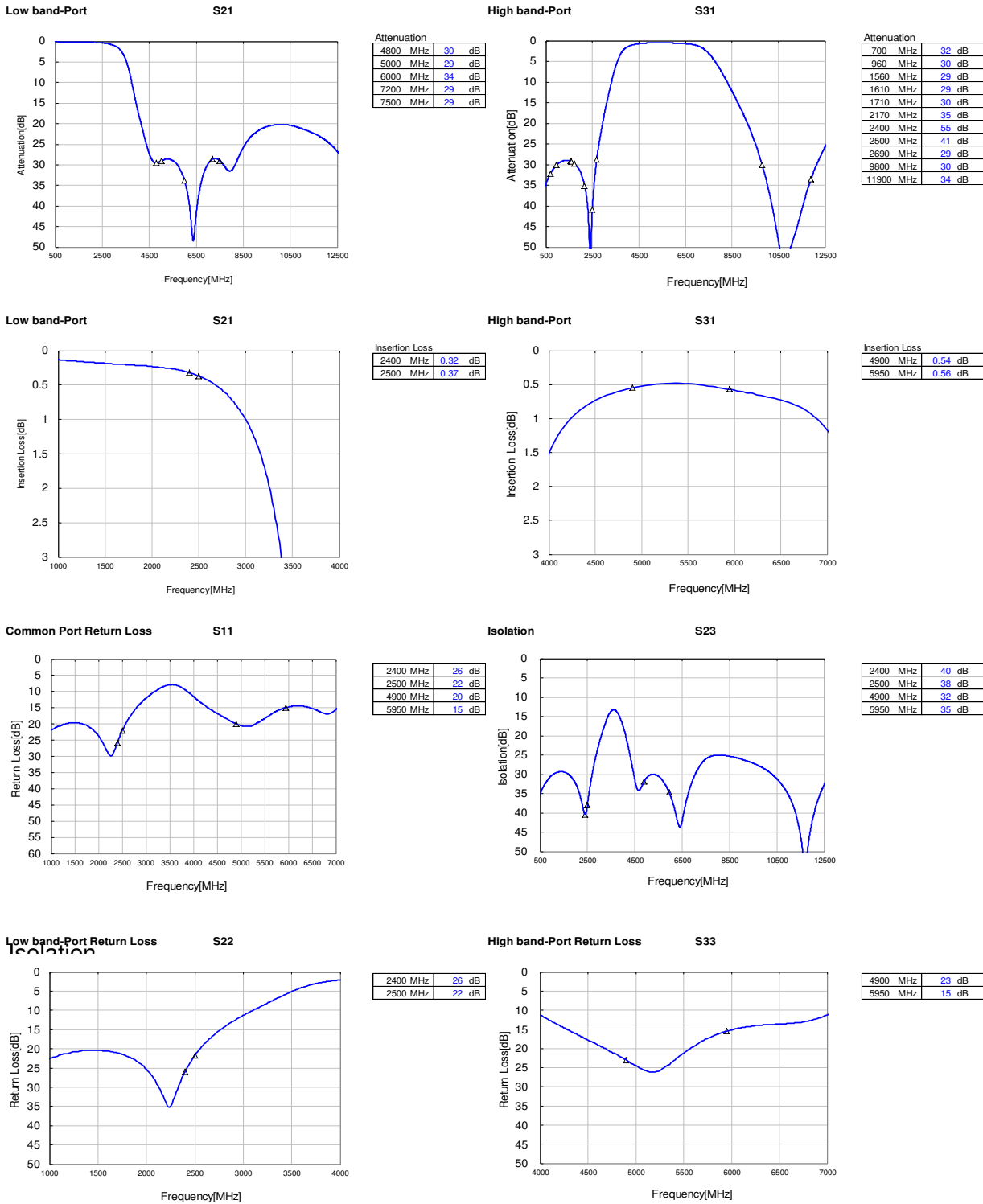

All specifications are subject to change without notice.

## DPX105950DT-6012A2

### RECOMMENDED LAND PATTERN

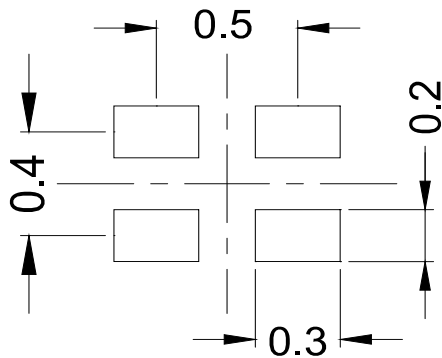

unit : mm

### EVALUATION BOARD

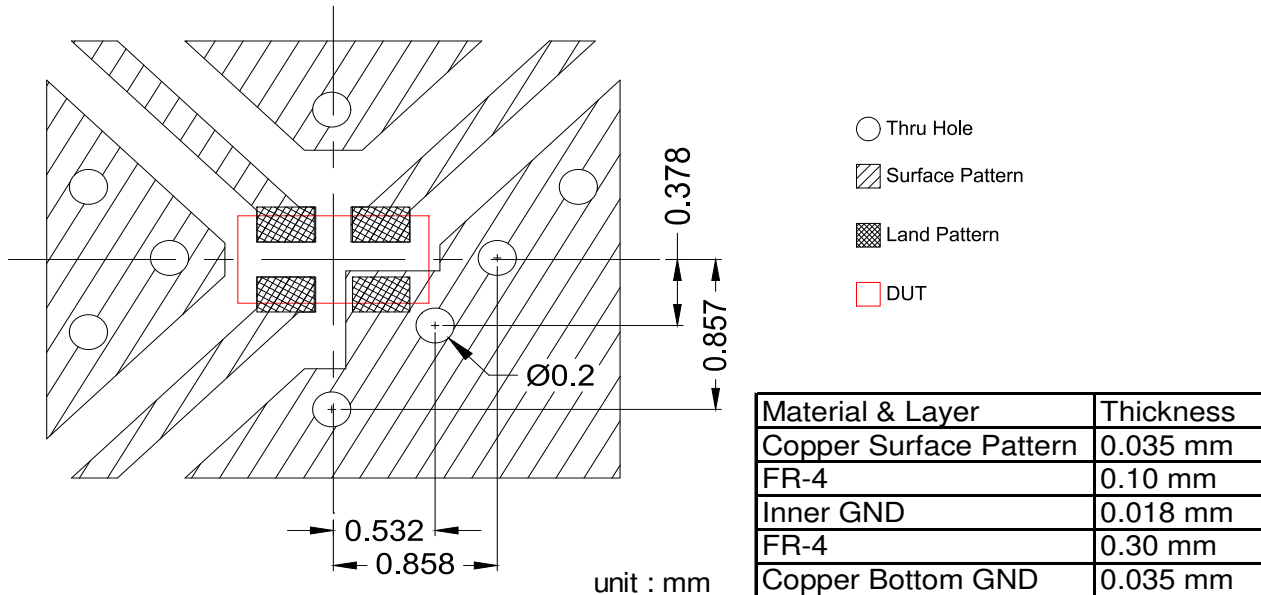

\* Line width should be designed to match 50 ohm characteristic impedance depending on PCB material and thickness.

\*\* The position of the through hole which have possibility of influence to the performance are indicated by dimension line.

### ENVIRONMENT INFORMATION

RoHS Statement  
 RoHS Compliance

## RECOMMENDED REFLOW PROFILE

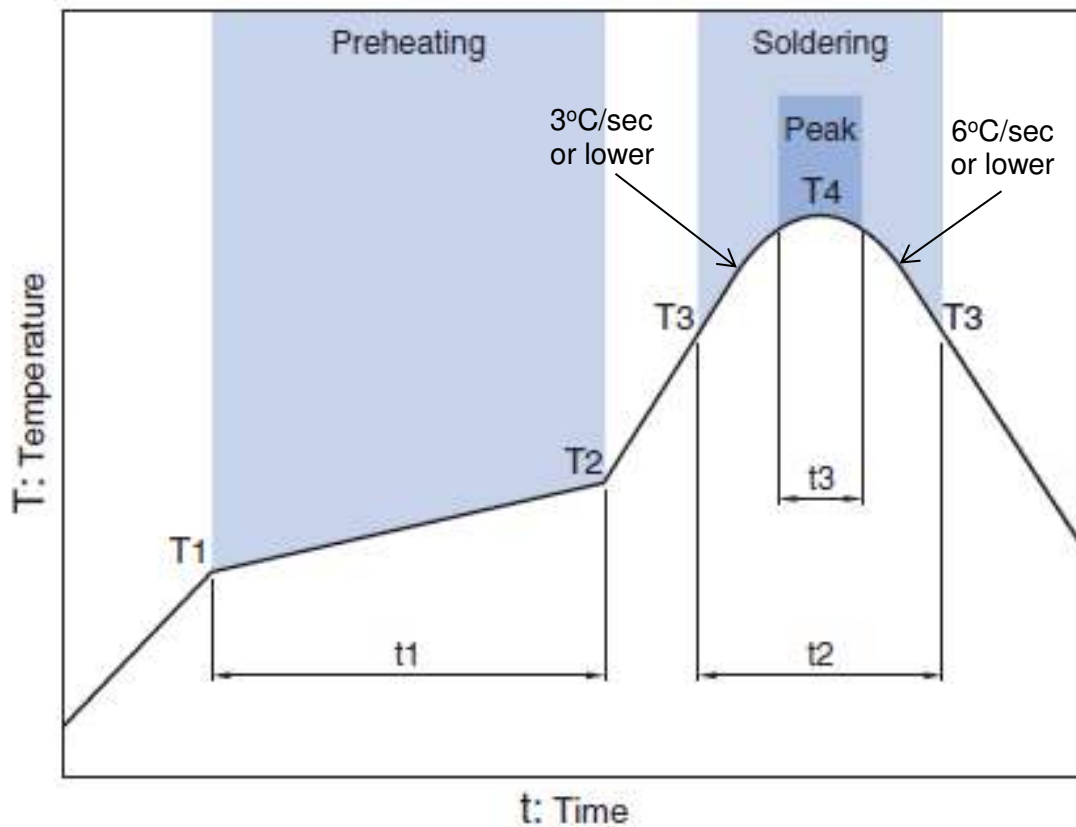

Preheating			Soldering			
Temp.		Time	Critical zone (T3 to T4)		Peak	
T1	T2	t1	T3	t2	T4	t3 *
150°C	200°C	60 to 120sec	217°C	60 to 120sec	240 to 260°C	30 sec Max

\* t3 : Time within 5°C of actual peak temperature

The maximum number of reflow is 3.

Note: Lead free solder is recommended.  
Recommended solder is Sn-3.0Ag-0.5Cu. (M705 by Senju Metal Industry)

# DPX105950DT-6012A2

## PACKAGING STYLE

Reel Dimensions

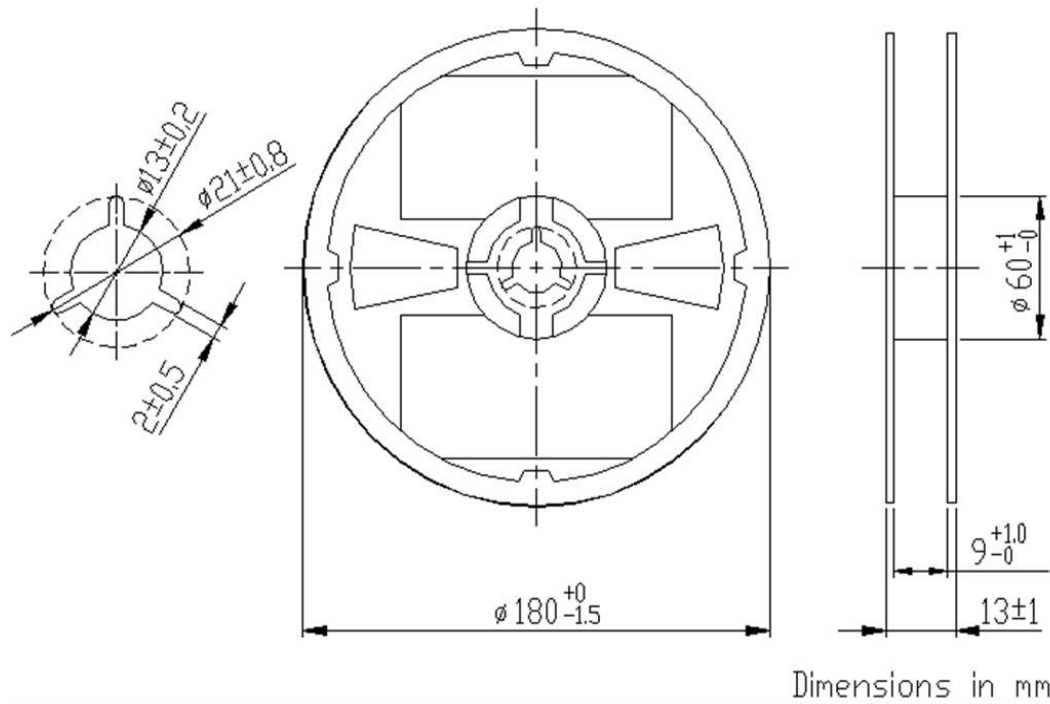

Carrier Tape

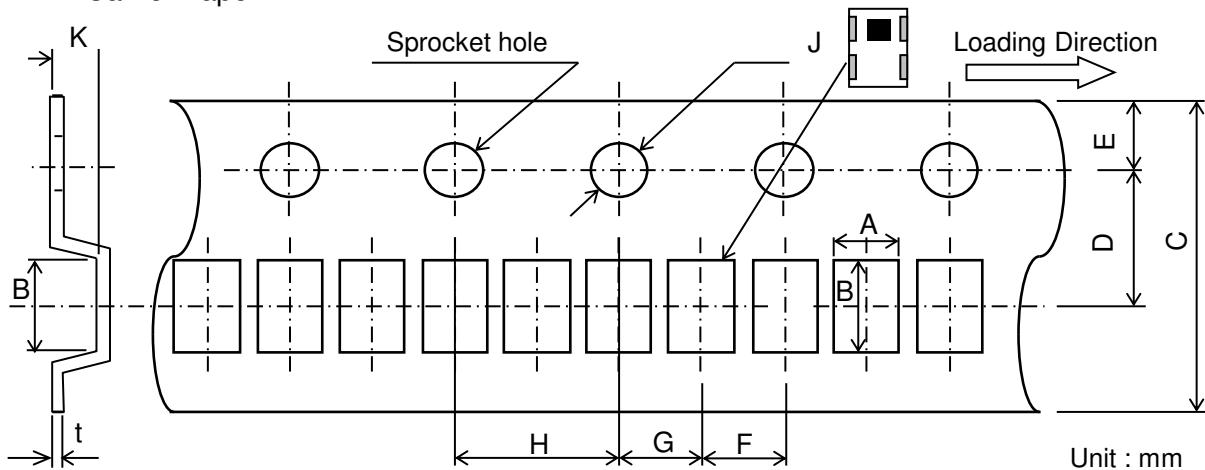

Dimensions (mm)

A	B	C	D	E	F	G	H	J	K	t
0.62	1.12	8.0	3.5	1.75	2.0	2.0	4.0	1.5	0.37	0.2
$\pm 0.05$	$\pm 0.05$	$\pm 0.2$	$\pm 0.05$	$\pm 0.1$	$\pm 0.05$	$\pm 0.05$	$\pm 0.05$	$+0.1/-0$	MAX	$\pm 0.05$

STANDARD PACKAGE QUANTITY ( pieces/reel )
10,000



## REMINDERS FOR USING THESE PRODUCTS

Before using these products, be sure to request the delivery specifications.

### SAFETY REMINDERS

Please pay sufficient attention to the warnings for safe designing when using these products.

 <b>REMINDERS</b>
--

The products listed on this specification sheet are intended for use in general electronic equipment (AV equipment, telecommunications equipment, home appliances, amusement equipment, computer equipment, personal equipment, office equipment, measurement equipment, industrial robots) under a normal operation and use condition.

The products are not designed or warranted to meet the requirements of the applications listed below, whose performance and/or quality require a more stringent level of safety or reliability, or whose failure, malfunction or trouble could cause serious damage to society, person or property. Please understand that we are not responsible for any damage or liability caused by use of the products in any of the applications below or for any other use exceeding the range or conditions set forth in this specification sheet.

1. Aerospace/Aviation equipment
2. Transportation equipment (cars, electric trains, ships, etc.)
3. Medical equipment
4. Power-generation control equipment
5. Atomic energy-related equipment
6. Seabed equipment
7. Transportation control equipment
8. Public information-processing equipment
9. Military equipment
10. Electric heating apparatus, burning equipment
11. Disaster prevention/crime prevention equipment
12. Safety equipment
13. Other applications that are not considered general-purpose applications

When using this product in general-purpose applications, you are kindly requested to take into consideration securing protection circuit/equipment or providing backup circuits, etc., to ensure higher safety.