

This document is the property of Amphenol Corporation and is delivered on the express condition that is not to be disclosed, reproduced or used, in whole or in part, for manufacture or sale by anyone other than Amphenol Corporation without its prior consent, and that no right is granted to disclose or to use any information in this document.

The marking on this product doesn't contain environmental hazardous materials per Material Specification 55-00259 for Sony GP compliant or per directive 2011/65/EU for RoHS compliant.



ORIGINAL



REVISIONS				
SYM	ECN No.	DESCRIPTION	DATE	APPROVED
A	NE-17110	RELEASE TO PRODUCTION	05/24/2017	Roger Tsai
B	NE-17244	ADDED TRAY PACKAGING	09/18/2017	Roger Tsai
C	NE-17285	ADDED 3.50MM TAIL OPTION	12/18/2017	Roger Tsai
D	NE-19126	ADDED 15u" GOLD OPTION	07/08/2019	Roger Tsai

PART NO. G861 XX X 2 X S2HR

NO. OF POSITION

COLOR / TAIL(DIMC) / PKG

- 1: WHITE / 1.80 / TUBE
- 2: BLACK / 1.80 / TUBE
- 3: WHITE / 3.00 / TUBE
- 4: BLACK / 3.00 / TUBE
- 5: WHITE / 3.50 / TUBE
- 6: BLACK / 3.50 / TUBE
- A: WHITE / 1.80 / T&R
- B: BLACK / 1.80 / T&R
- C: WHITE / 3.00 / T&R
- D: BLACK / 3.00 / T&R
- J: WHITE / 3.50 / T&R
- K: BLACK / 3.50 / T&R
- E: WHITE / 1.80 / TRAY
- F: BLACK / 1.80 / TRAY
- G: WHITE / 3.00 / TRAY
- H: BLACK / 3.00 / TRAY
- L: WHITE / 3.50 / TRAY
- M: BLACK / 3.50 / TRAY

CONTACT/SOLDER FINISH:

- 1: 100u" MATTE TIN/100u" MATTE TIN
- 2: GOLD FLASH/GOLD FLASH
- 4: 15u" GOLD/15u" GOLD

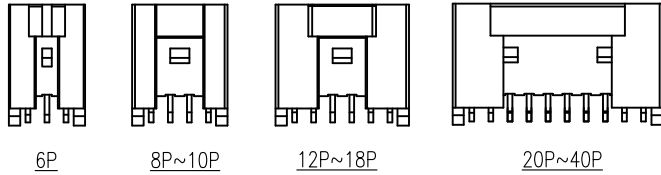

6P      8P~10P      12P~18P      20P~40P

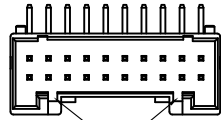

6P~14P WITHOUT GUIDEWAY  
16P~40P WITH GUIDEWAY

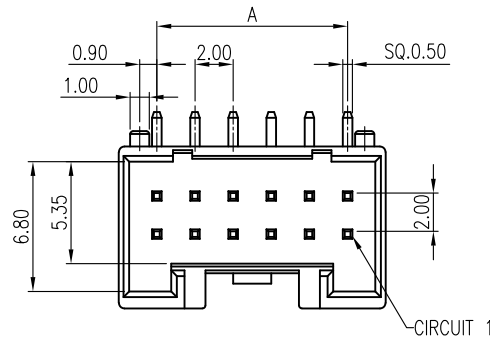

CIRCUIT 1

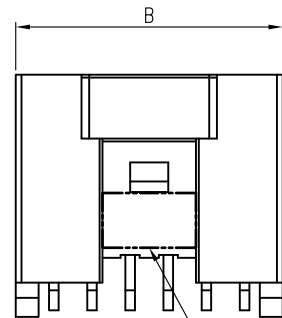
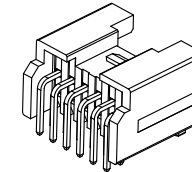

SMT AREA

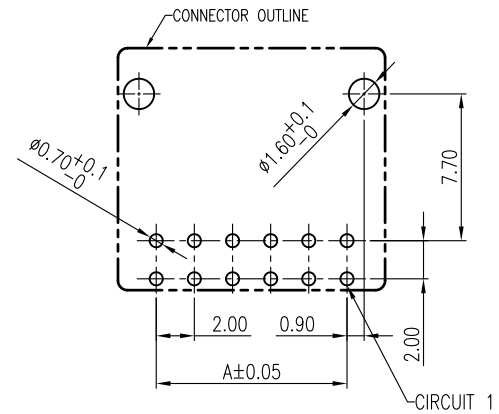
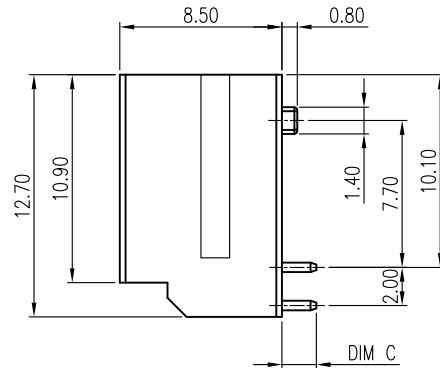

Recommended P.C.B LAYOUT  
General Tolerance±0.05

NUMBER OF POS.	Dimensions (mm)	
	A	B
2*03=06	4.00	8.00
2*04=08	6.00	10.00
2*05=10	8.00	12.00
2*06=12	10.00	14.00
2*07=14	12.00	16.00
2*08=16	14.00	18.00
2*09=18	16.00	20.00
2*10=20	18.00	22.00
2*11=22	20.00	24.00
2*12=24	22.00	26.00
2*13=26	24.00	28.00
2*14=28	26.00	30.00
2*15=30	28.00	32.00
2*16=32	30.00	34.00
2*17=34	32.00	36.00
2*18=36	34.00	38.00
2*19=38	36.00	40.00
2*20=40	38.00	42.00

TOLERANCE		APPROVALS		DATE		TITLE		Amphenol®	
X.		DRAWN	Aqua Chou		07/08/2019	G861 SERIES, PROTECT HEADER, 2.00 PITCH, R/A PCB MOUNT, W/POST		Amphenol Corporation Amphenol Taiwan Corporation	
X.X	±0.30	CHECKED	Karen Su		07/08/2019				
X.XX	±0.20	APPROVED	Roger Tsai		07/08/2019				
X.XXX	±0.10					UNIT	mm	SIZE	A3
ANGULAR	±1°					SCALE	NA	SHEET	1 OF 4
UNLESS OTHERWISE SPECIFIED		DWG TYPE		PROJECT CODE		PART No.		DWG No.	
		CUST DWG		PHD		G861XXX2XS2HR		G861XXX2XS2HR	
								REV. D	

This document is the property of Amphenol Corporation and is delivered on the express condition that is not to be disclosed, reproduced or used, in whole or in part, for manufacture or sale by anyone other than Amphenol Corporation without its prior consent, and that no right is granted to disclose or to use any information in this document.

The marking on this product doesn't contain environmental hazardous materials per Material Specification SS-00259 for Sony GP compliant or per directive 2011/65/EU for RoHS compliant.



ORIGINAL



REVISIONS				
SYM	ECN No.	DESCRIPTION	DATE	APPROVED
A	NE-17110	RELEASE TO PRODUCTION	05/24/2017	Roger Tsai
B	NE-17244	ADDED TRAY PACKAGING	09/18/2017	Roger Tsai
C	NE-17285	ADDED 3.50MM TAIL OPTION	12/18/2017	Roger Tsai
D	NE-19126	ADDED 15u" GOLD OPTION	07/08/2019	Roger Tsai

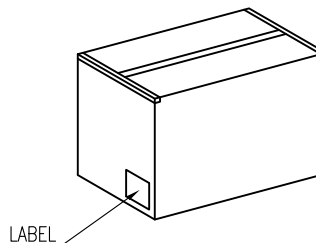
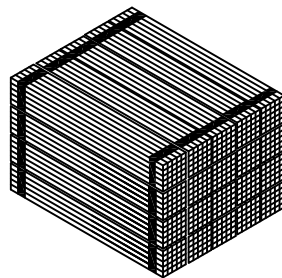
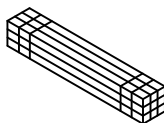
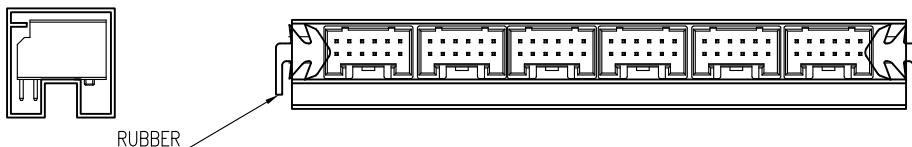

SHIPPING CARTON  
SIZE: 600X200X180MM

POS.	PCS/TUBE	TUBE/CARTON	PCS/CARTON
2x04	58	9X14=126	7308
2x05	48	9X14=126	6048
2x06	41	9X14=126	5166
2x07	36	9X14=126	4536
2x08	32	9X14=126	4032
2x09	29	9X14=126	3654
2x10	26	9X14=126	3276
2x11	24	9X14=126	3024
2x12	22	9X14=126	2772
2x13	20	9X14=126	2520
2x14	19	9X14=126	2394
2x15	18	9X14=126	2268
2x16	17	9X14=126	2142
2x17	16	9X14=126	2016
2x18	15	9X14=126	1890
2x19	14	9X14=126	1764
2x20	13	9X14=126	1638

TOLERANCE	APPROVALS	DATE	TITLE		PART No.	
X. ±0.30	DRAWN Aqua Chou	07/08/2019	G861 SERIES, PROTECT HEADER, 2.00 PITCH, R/A PCB MOUNT, W/POST		<b>Amphenol</b> <sup>®</sup> Amphenol Corporation Amphenol Taiwan Corporation	
X.X ±0.20	CHECKED Karen Su	07/08/2019				
X.XXX ±0.10	APPROVED Roger Tsai	07/08/2019				
ANGULAR ±1°	DWG TYPE CUST DWG	PROJECT CODE PHD		UNIT mm	SIZE A3	PART No. G861XXX2XS2HR
UNLESS OTHERWISE SPECIFIED				SCALE NA	SHEET 2 OF 4	DWG No. G861XXX2XS2HR
						REV. D

This document is the property of Amphenol Corporation and is delivered on the express condition that is not to be disclosed, reproduced or used, in whole or in part, for manufacture or sale by anyone other than Amphenol Corporation without its prior consent, and that no right is granted to disclose or to use any information in this document.

The marking on this product doesn't contain environmental hazardous materials per Material Specification SS-00259 for Sony GP compliant or per directive 2011/65/EU for RoHS compliant.



ORIGINAL



REVISIONS					
SYM	ECN No.	DESCRIPTION	DATE	APPROVED	
A	NE-17110	RELEASE TO PRODUCTION	05/24/2017	Roger Tsai	
B	NE-17244	ADDED TRAY PACKAGING	09/18/2017	Roger Tsai	
C	NE-17285	ADDED 3.50MM TAIL OPTION	12/18/2017	Roger Tsai	
D	NE-19126	ADDED 15u" GOLD OPTION	07/08/2019	Roger Tsai	

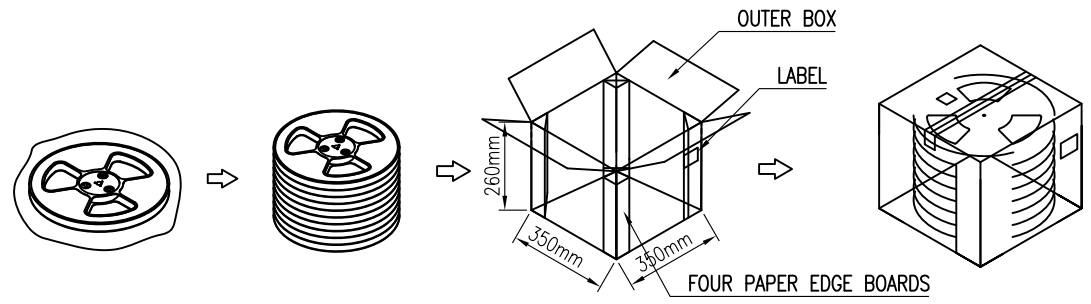
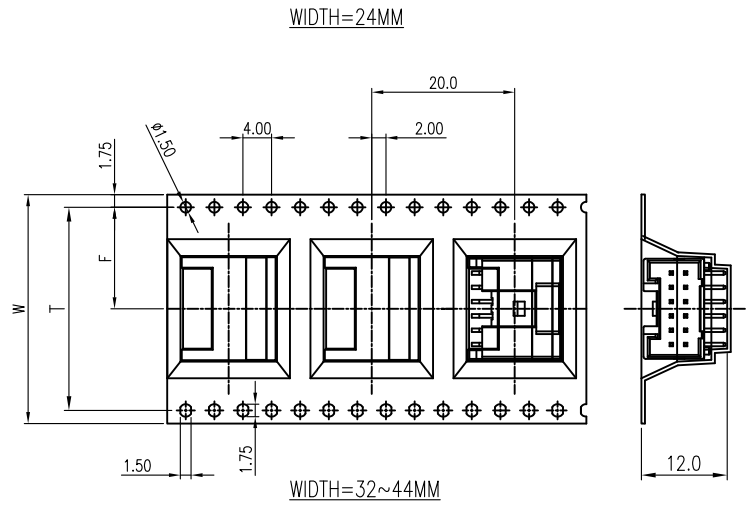
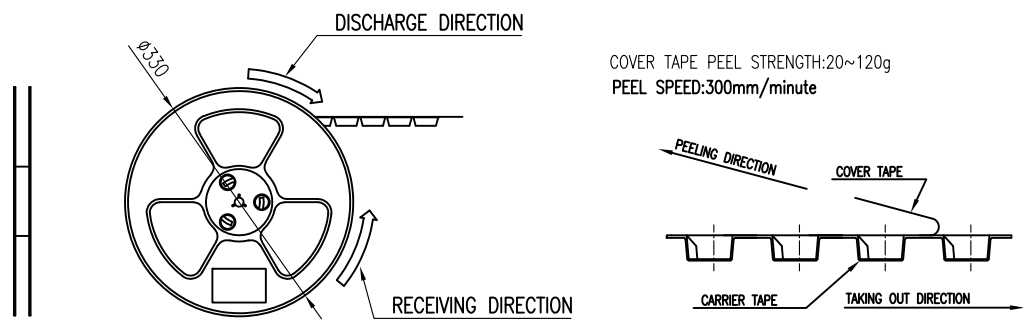
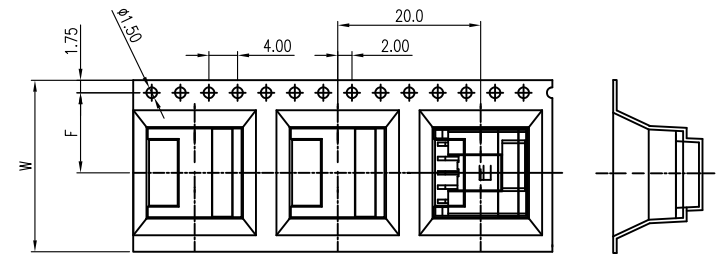
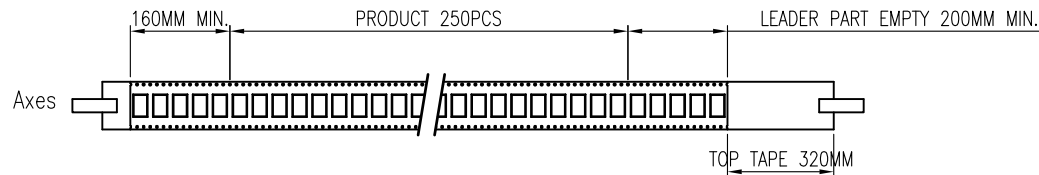

2X16=32~2X20=40	56	52.4	26.2	250	4R	1000
2X10=20~2X15=30	44	40.4	20.2	250	4R	1000
2X06=12~2X09=18	32	28.4	14.2	250	6R	1500
2X04=08~2X05=10	24	/	11.5	250	8R	2000
PIN NO.	W	T	F	REEL /PCS	CARTON /R	CARTON /PCS

TOLERANCE		APPROVALS		DATE	TITLE		Amphenol®						
X.		DRAWN	Aqua Chou	07/08/2019	G861 SERIES, PROTECT HEADER, 2.00 PITCH, R/A PCB MOUNT, W/POST		Amphenol Corporation Amphenol Taiwan Corporation						
X.X	±0.30	CHECKED	Karen Su	07/08/2019									
X.XX	±0.20	APPROVED	Roger Tsai	07/08/2019									
X.XXX	±0.10					UNIT	mm	SIZE	A3	PART No.	G861XXX2XS2HR		
ANGULAR	±1°	DWG TYPE	CUST DWG	PROJECT CODE	PHD	SCALE	NA	SHEET	3 OF 4	DWG No.	G861XXX2XS2HR	REV.	D
UNLESS OTHERWISE SPECIFIED													

This document is the property of Amphenol Corporation and is delivered on the express condition that is not to be disclosed, reproduced or used, in whole or in part, for manufacture or sale by anyone other than Amphenol Corporation without its prior consent, and that no right is granted to disclose or to use any information in this document.

The marking on this product doesn't contain environmental hazardous materials per Material Specification SS-00259 for Sony GP compliant or per directive 2011/65/EU for RoHS compliant.



ORIGINAL



REVISIONS				
SYM	ECN No.	DESCRIPTION	DATE	APPROVED
A	NE-17110	RELEASE TO PRODUCTION	05/24/2017	Roger Tsai
B	NE-17244	ADDED TRAY PACKAGING	09/18/2017	Roger Tsai
C	NE-17285	ADDED 3.50MM TAIL OPTION	12/18/2017	Roger Tsai
D	NE-19126	ADDED 15u" GOLD OPTION	07/08/2019	Roger Tsai

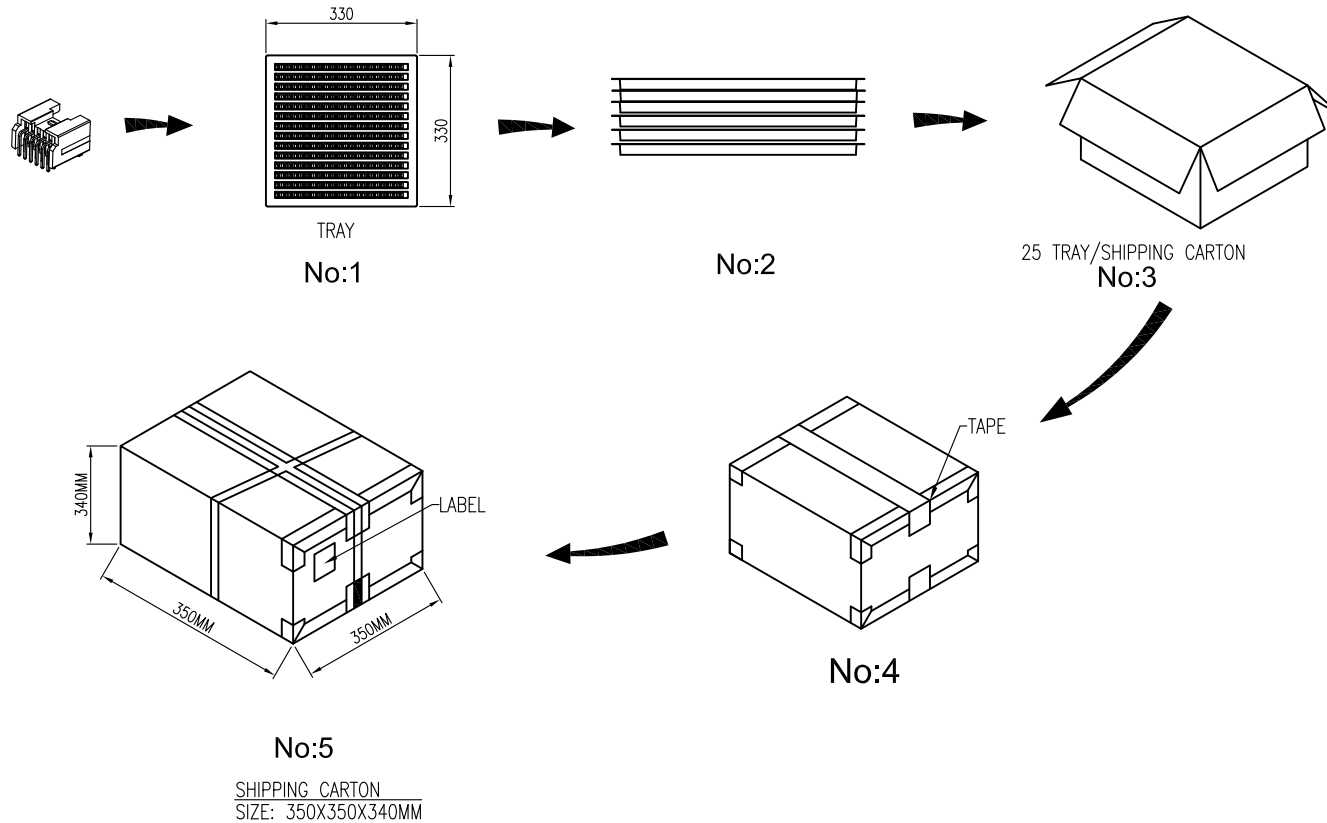

POS.	PCS/TRAY	TRAY/CARTON	PCS/CARTON
2x03	504	25	12600
2x04	406	25	10150
2x05	336	25	8400
2x06	280	25	7000
2x07	252	25	6300
2x08	224	25	5600
2x09	196	25	4900
2x10	182	25	4550
2x11	168	25	4200
2x12	154	25	3850
2x13	140	25	3500
2x14	126	25	3150
2x15	126	25	3150
2x16	112	25	2800
2x17	112	25	2800
2x18	98	25	2450
2x19	98	25	2450
2x20	84	25	2100

TOLERANCE	APPROVALS	DATE	TITLE		Amphenol®			
X. ±0.30	DRAWN Aqua Chou	07/08/2019	G861 SERIES, PROTECT HEADER, 2.00 PITCH, R/A PCB MOUNT, W/POST		Amphenol Corporation Amphenol Taiwan Corporation			
X.X ±0.20	CHECKED Karen Su	07/08/2019						
X.XXX ±0.10	APPROVED Roger Tsai	07/08/2019						
ANGULAR ±1°	DWG TYPE CUST DWG	PROJECT CODE PHD	UNIT mm	SCALE NA	SIZE A3	PART No. G861XXX2XS2HR		
UNLESS OTHERWISE SPECIFIED			SHEET 4 OF 4	DWG No. G861XXX2XS2HR		REV. D		