

THIS DRAWING IS UNPUBLISHED. RELEASED FOR PUBLICATION
 © COPYRIGHT BY TYCO ELECTRONICS CORPORATION. ALL RIGHTS RESERVED.

LOC	DIST	REVISIONS			
P	LTR	DESCRIPTION	DATE	DWN	APVD
AJ	16	M	REVISED PER EC OS14-0173-05	26JULY05	BM JL

1. CRIMP TOOL: 69141-1
- ② RG-59/U,59A/U,59B/U,62/U,62A/U,62B/U,124/U,140/U AND 210/U
- ③ SUPERNAUT-TYPE 6244,MODIFIED TO SPEC IM-138 (1250)
4. SEE I.S. 1799-1

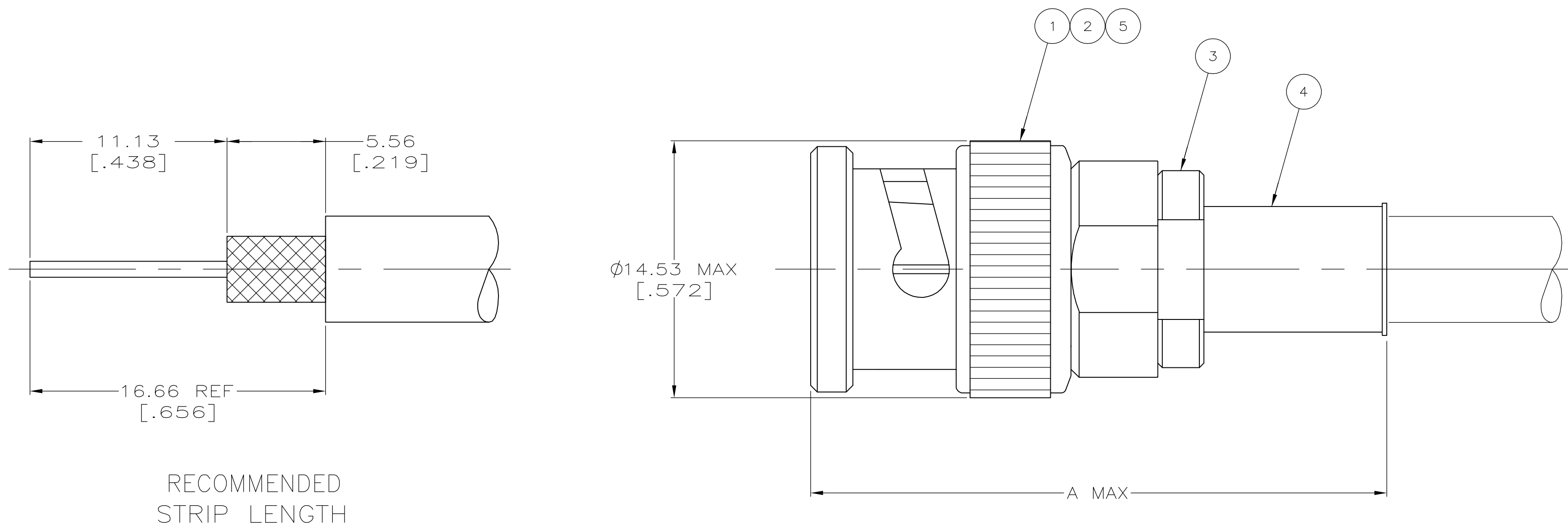

RECOMMENDED STRIP LENGTH

SUPERSEDED BY 2-5329083-1	34.93 [1.375]	②	.416 OZ	-	329041	50780-2	2-329106-1	9-329327-0	9-329083-0
OBSOLETE	35.20 [1.386]	③	-	51553-2	50428-1	50780-2	2-329106-1	329327	2-329083-3
SUPERSEDED BY 2-329445-2	-	-	-	-	-	-	-	-	2-329083-2
	34.93 [1.375]	②	.416 OZ	-	329041	50780-2	2-329106-1	329327	2-329083-1
A	CABLE	WEIGHT	⑤ BUSHING QTY=1	④ FERRULE QTY=1	③ CRIMP END ASSEMBLY QTY=1	② GASKET QTY=1	① PLUG ASSEMBLY QTY=1	PART NUMBER	

THIS DRAWING IS A CONTROLLED DOCUMENT.

DWN B. SCOTT 07-01-91	Tyco Electronics Corporation Harrisburg, Pa 17105-3608	SIZE	CAGE CODE	DRAWING NO	RESTRICTED TO
CHK J. LIPPERT 7-30-91		A2	00779	③=329083	-
APVD M. PHILLIPS 7-30-91		SCALE	SHEET	OF	REV
PRODUCT SPEC		5:1	1	1	M
APPLICATION SPEC	CUSTOMER DRAWING				