

BASE CAGE DETAILS

2033711244 SHOWN

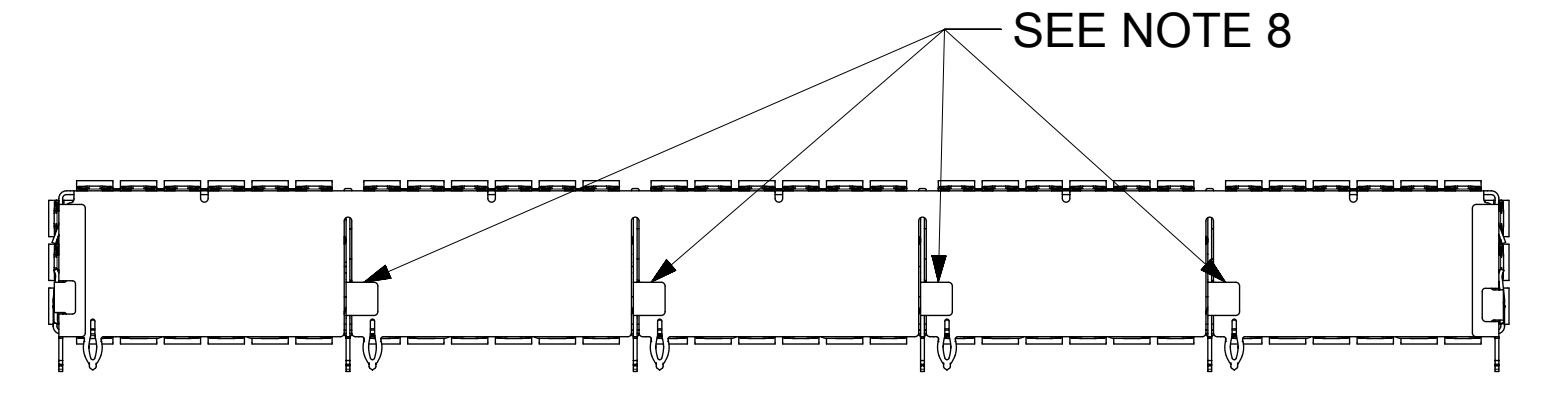
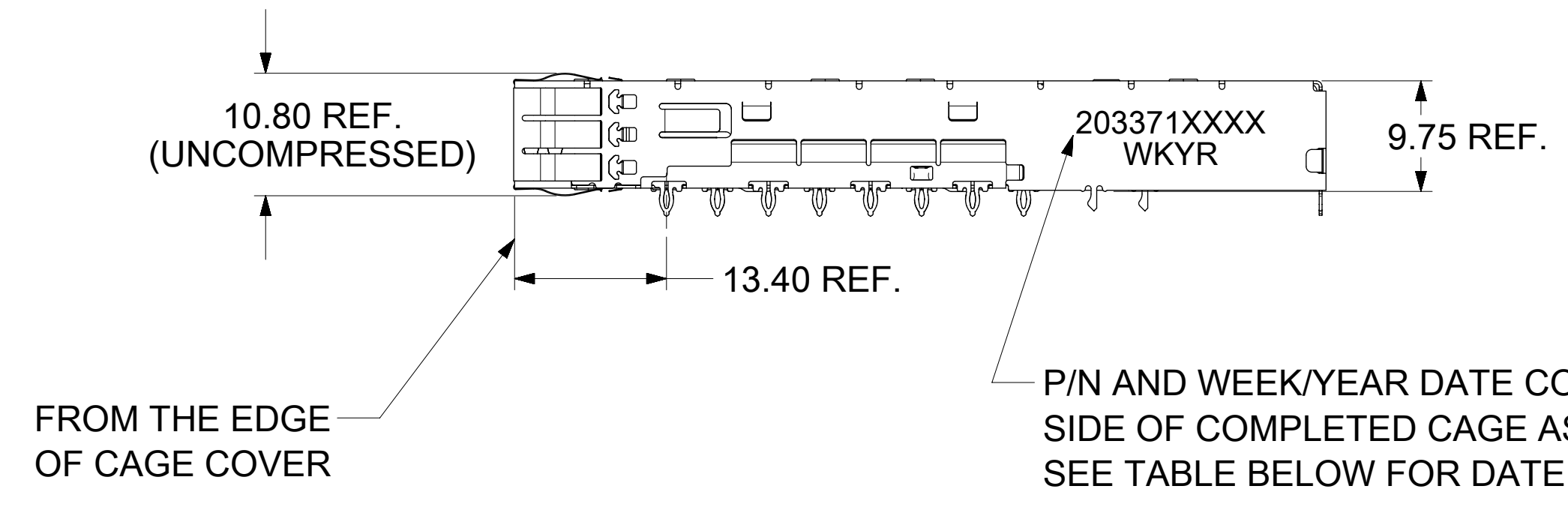
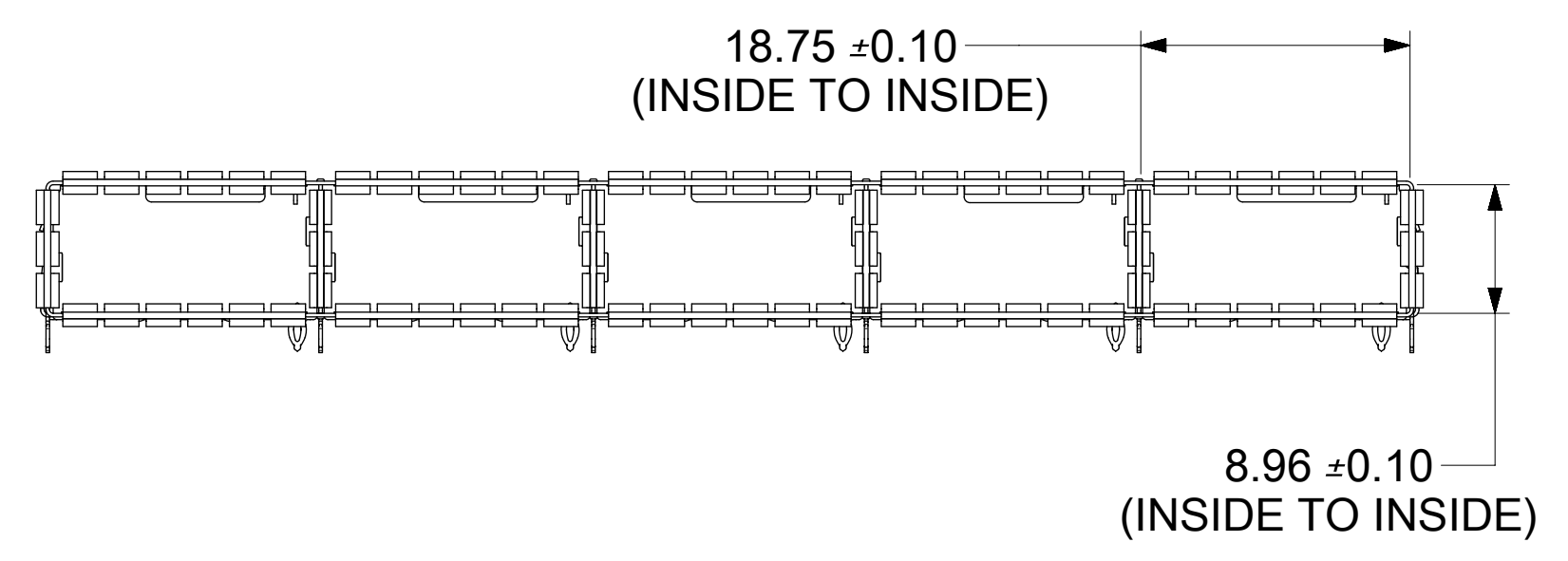
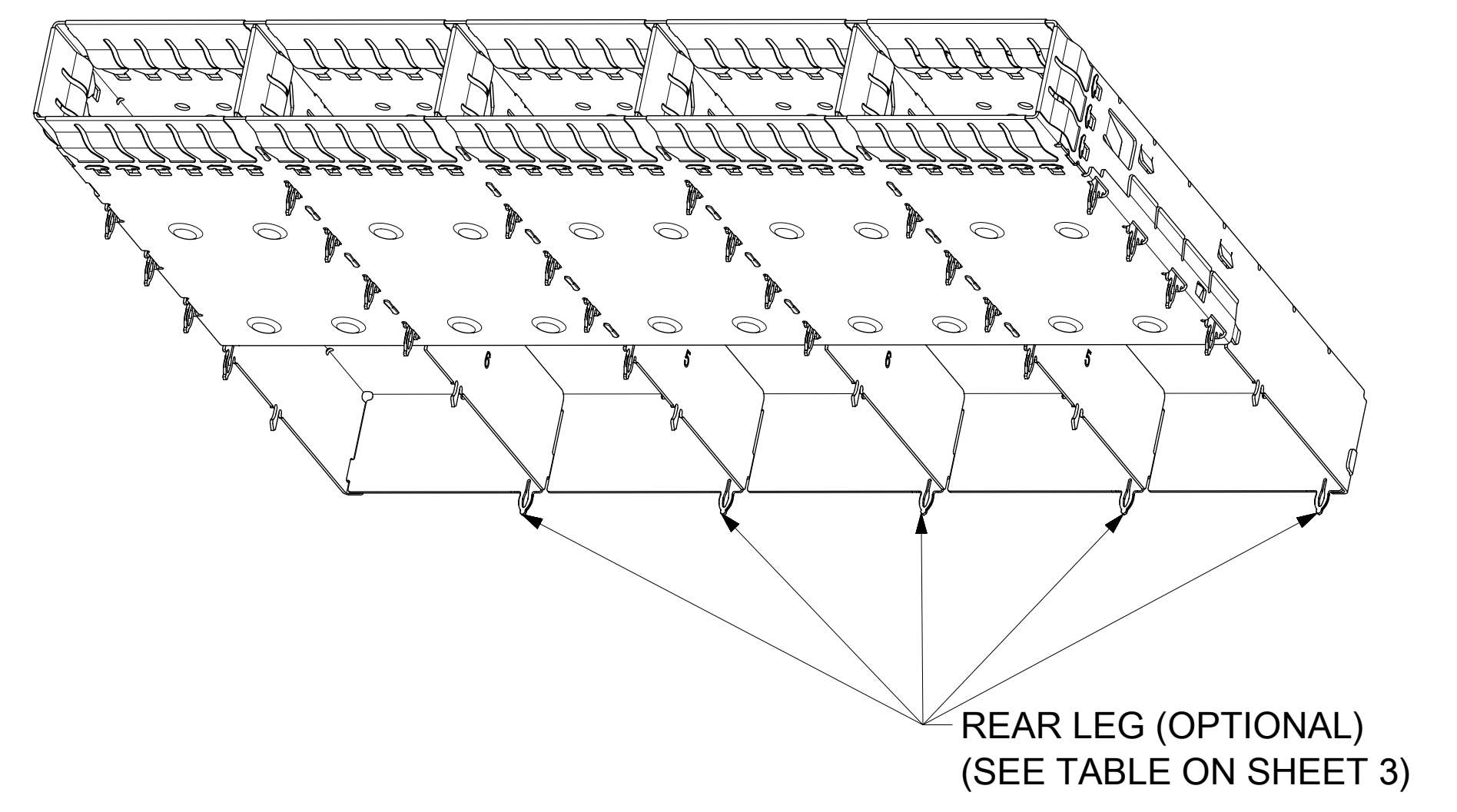
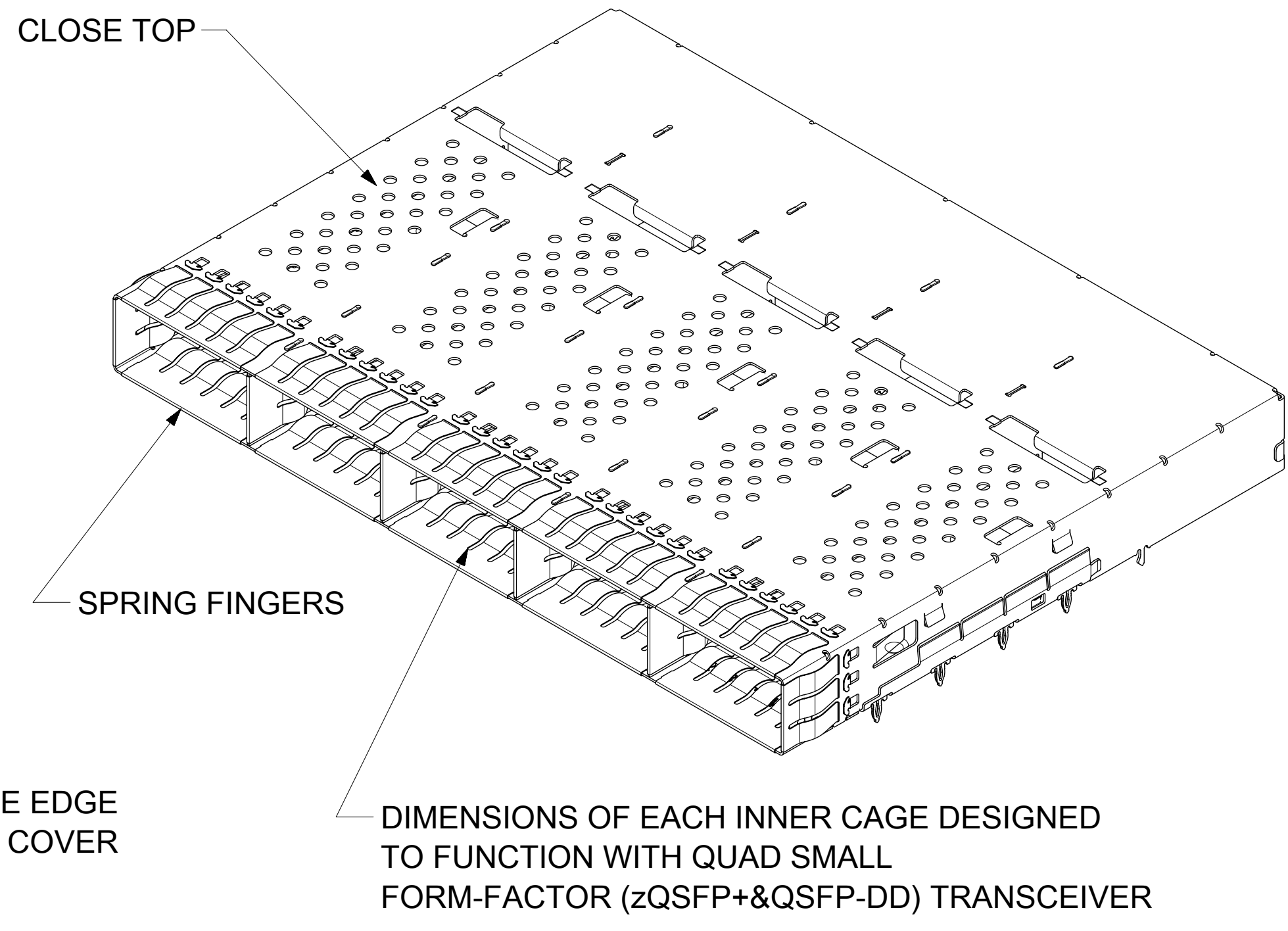
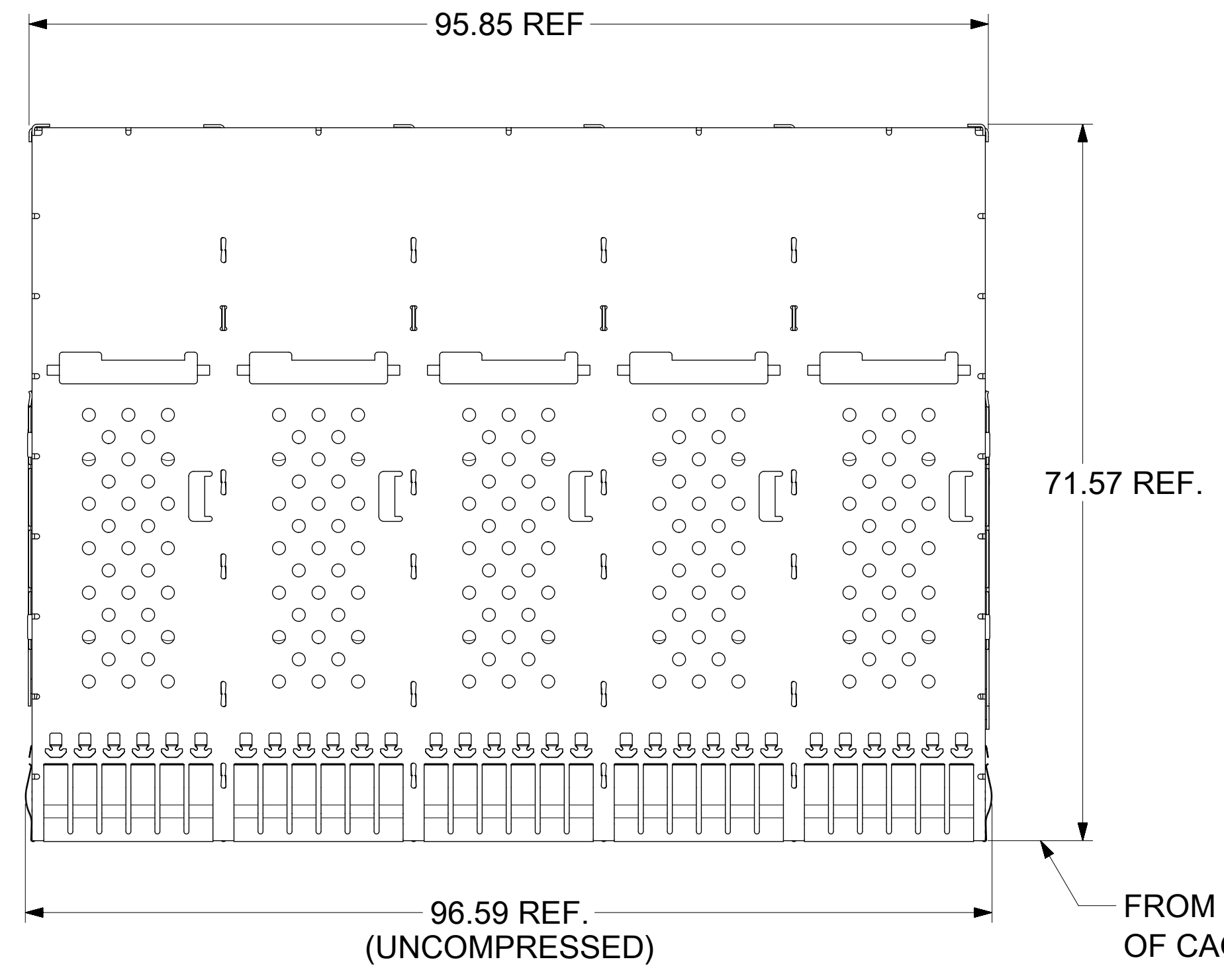

- NOTES:**
- MATERIAL: CAGE: STAINLESS STEEL
 CENTER WALLS: STAINLESS STEEL
 SPRING FINGERS: STAINLESS STEEL
 HEAT SINK: ALUMINUM(BLACK ANODIZATION)
 HEAT SINK CLIP: STAINLESS STEEL
 - DRAWING APPLIES TO ALL P/N'S SHOWN ON PAGE 3.
 - DURING FINAL INSPECTION, CAGE LEG LOCATIONS AND STRAIGHTNESS MUST BE CHECKED USING APPROPRIATE GO - NO GO GAGE
 - DURING FINAL INSPECTION, CAGE MUST BE INSPECTED TO MAKE SURE LEG CONFIGURATIONS AND PART NUMBERS ARE CORRECT, REFER TO SHEETS 3.
 - PARTS TO BE INSPECTED PER MOLEX COSMETIC SPEC WI-HP-7-2774 (CLASS B UNLESS OTHERWISE SPECIFIED)
 - PRESS-FIT LEGS 2.20mm LONG -
 1.57mm MINIMUM PCB THICKNESS FOR SINGLE SIDED USE.
 2.70mm MINIMUM PCB THICKNESS FOR BELLY TO BELLY USE.
 - NO RoHS EXEMPTIONS.
 - WELD SPOT MAY SHOW SLIGHT MATERIAL DISCOLORATION.

WEEK/YEAR DATE CODE TABLE	
WK	WEEK OF THE YEAR 01 THRU 52 OR 53 (EXAMPLE: 01= FIRST WEEK OF YEAR, 52 OR 53 = LAST WEEK OF YEAR)
YR	17, 18, 19 ETC.. (EXAMPLE: YEAR 2017= 17)

THIS DRAWING CONTAINS INFORMATION THAT IS PROPRIETARY TO MOLEX ELECTRONIC TECHNOLOGIES, LLC AND SHOULD NOT BE USED WITHOUT WRITTEN PERMISSION										
DIMENSION UNITS	SCALE	CURRENT REV DESC: SEE REVISION TABLE								
mm	2:1	<p>QSFP-DD 1X5 GANGED CAGE ASSY SF WITH FIN H/S OPTIONS</p> <p>PRODUCT CUSTOMER DRAWING</p>								
GENERAL TOLERANCES (UNLESS SPECIFIED)										
ANGULAR TOL	± 2.0°									
4 PLACES	±									
3 PLACES	±									
2 PLACES	± 0.13	EC NO: 629406	2019/12/13							
1 PLACE	± 0.25	DRWN: JYEN01	2019/12/20							
0 PLACES	±	CHK'D: SCHIEN	2019/12/20							
DRAFT WHERE APPLICABLE MUST REMAIN WITHIN DIMENSIONS		THIRD ANGLE PROJECTION		DRAWING	SERIES	MATERIAL NUMBER				
		D-SIZE		203371	2033711201					
		GENERAL MARKET		SEE P/N TABLE				PSD	ASY	D3
				CUSTOMER				SHEET NUMBER		
				GENERAL MARKET				1 OF 7		

CAGE ASSEMBLY OPTIONS

2033712346 SHOWN

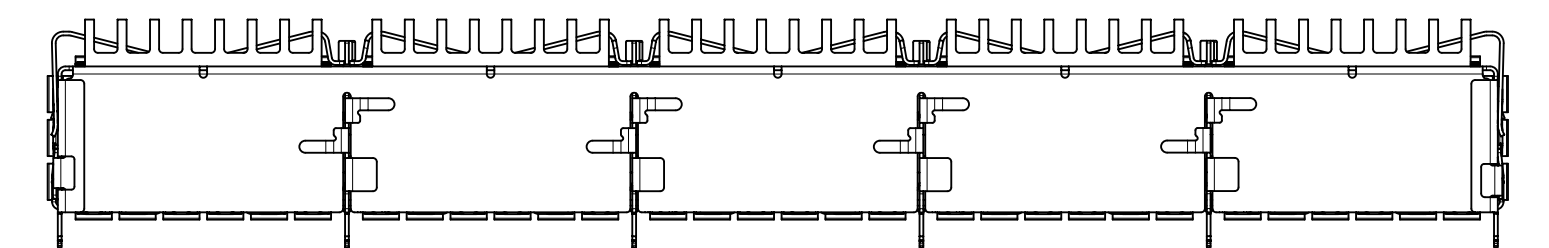
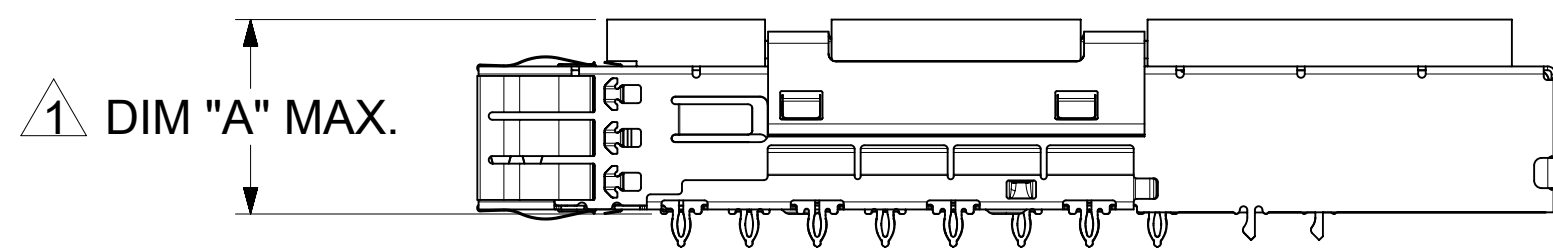
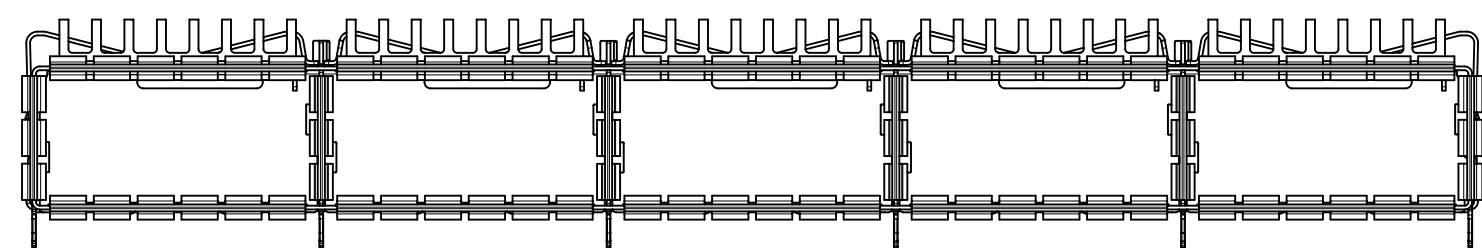
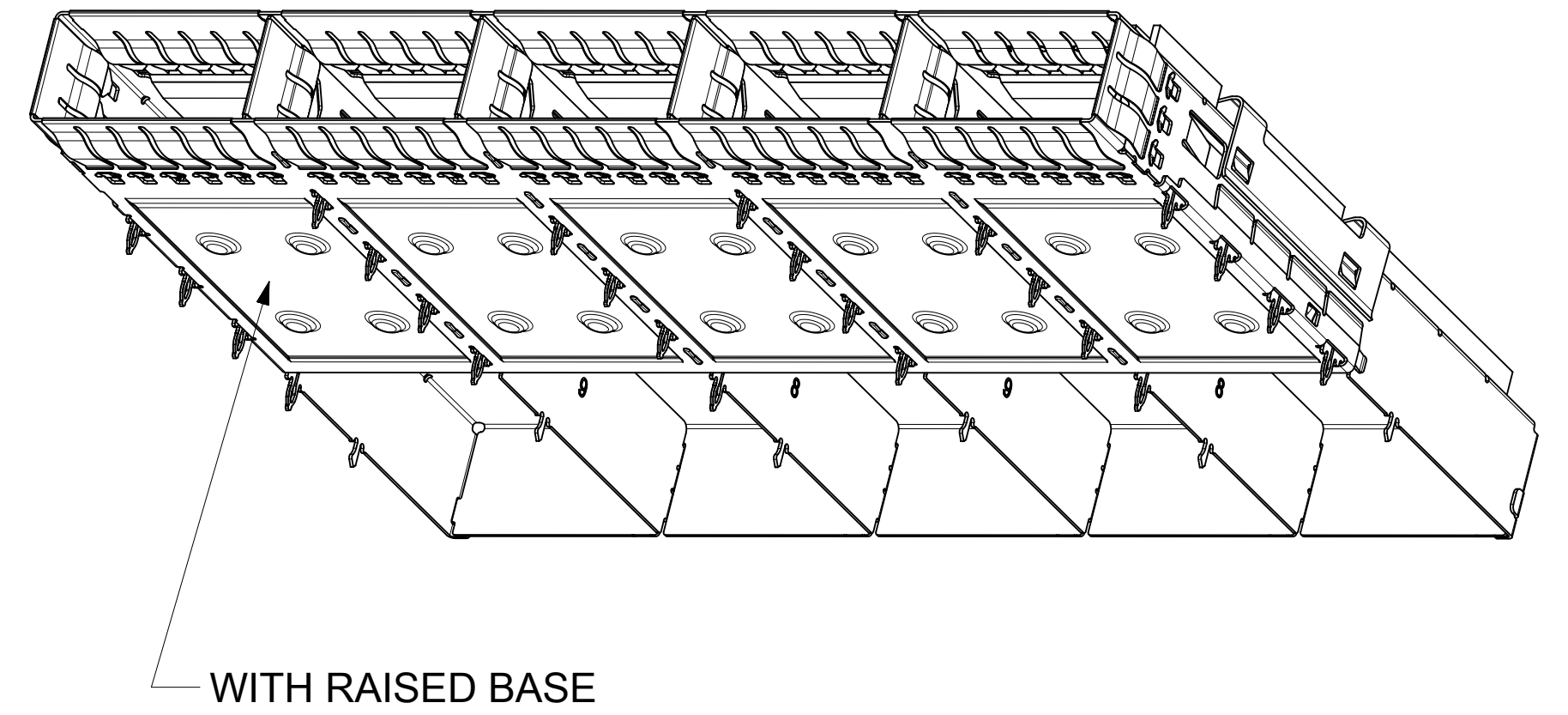
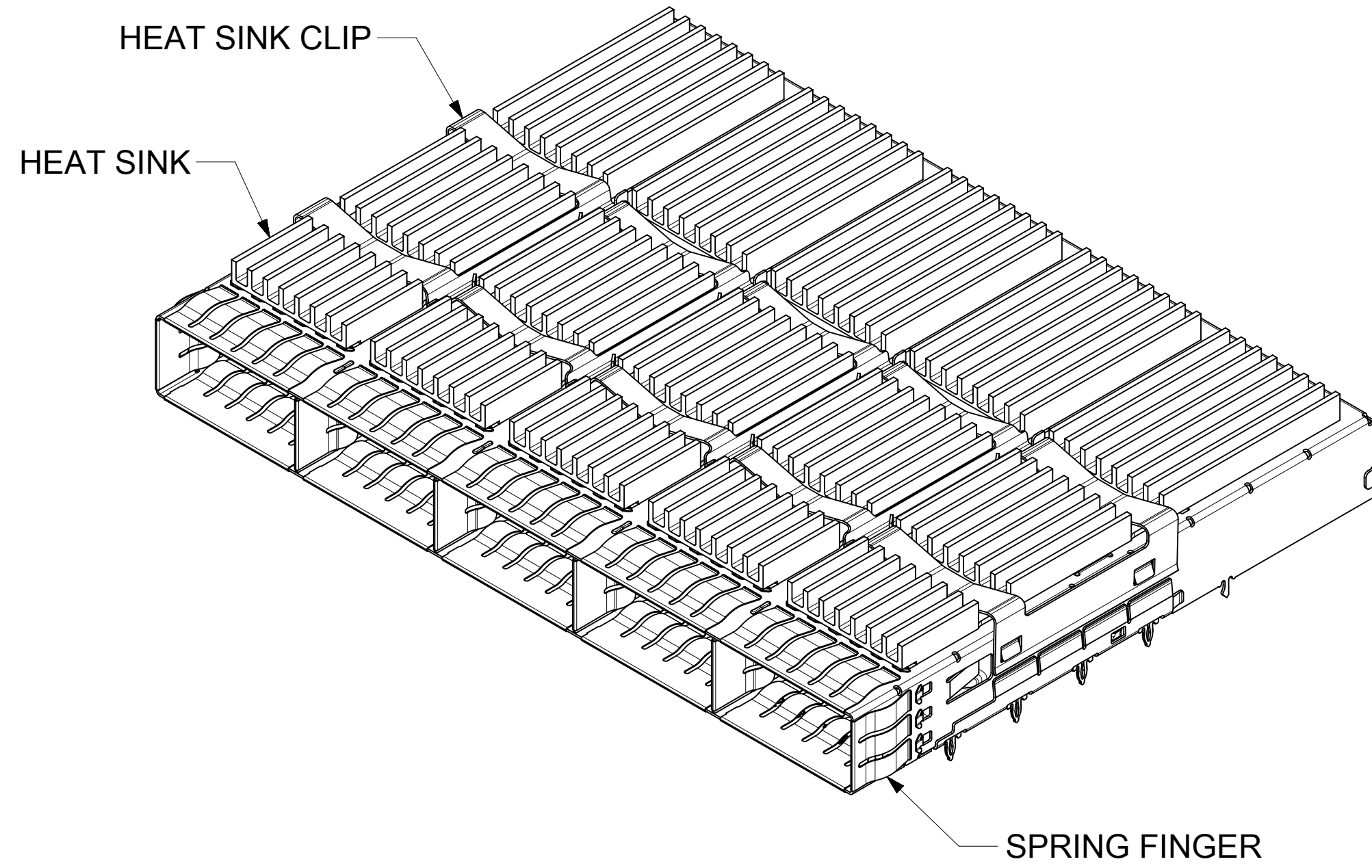
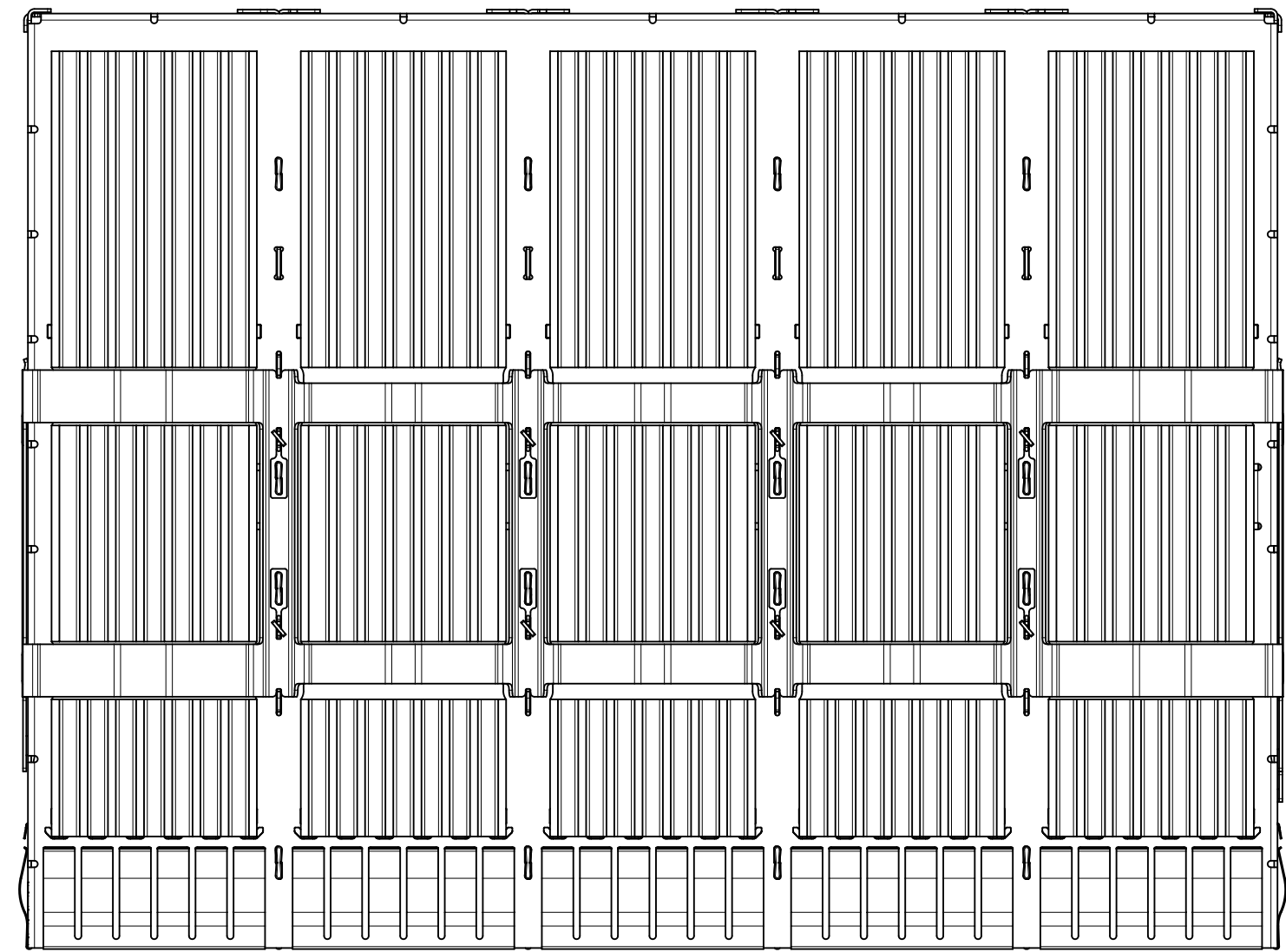

REAR LEG OPTIONS

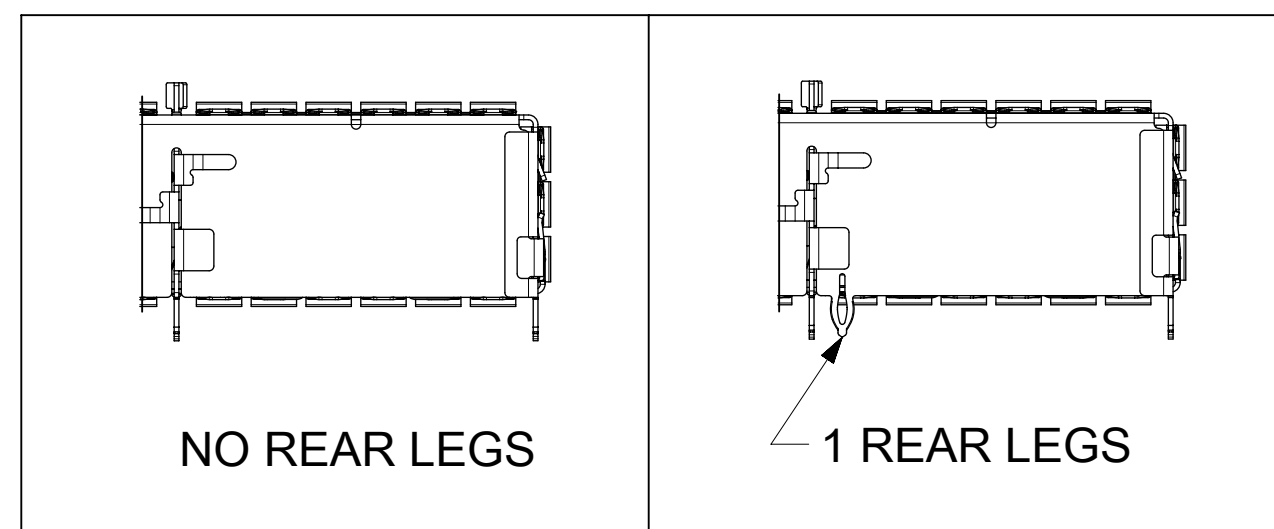

HEAT SINK HEIGHT OPTIONS

OVERALL HEAT SINK HEIGHT	DIM "A"
PCI	13.7
SAN	16.0
NET	23.0

△ HEIGHT OF HEAT SINK WITH MODULE INSERTED. DIMENSION MAY BE LESS DUE TO MODULE AND HEAT SINK VARIATIONS.

THIS DRAWING CONTAINS INFORMATION THAT IS PROPRIETARY TO MOLEX ELECTRONIC TECHNOLOGIES, LLC AND SHOULD NOT BE USED WITHOUT WRITTEN PERMISSION

DIMENSION UNITS	SCALE	CURRENT REV DESC: SEE REVISION TABLE	
mm	2.5:1		
GENERAL TOLERANCES (UNLESS SPECIFIED)			
ANGULAR TOL	± 2.0°	EC NO:	629406
4 PLACES	±	DRWN:	JYEN01 2019/12/13
3 PLACES	±	CHK'D:	SCHIEN 2019/12/20
2 PLACES	± 0.13	APPR:	JCHIANG 2019/12/20
1 PLACE	± 0.25	INITIAL REVISION:	
0 PLACES	±	DRWN:	MKEMPEGOWDA 2017/07/24
DRAFT WHERE APPLICABLE MUST REMAIN WITHIN DIMENSIONS		APPR:	RCHEN08 2017/08/15
THIRD ANGLE PROJECTION	DRAWING	SERIES	MATERIAL NUMBER
	D-SIZE	203371	SEE P/N TABLE
CUSTOMER		SHEET NUMBER	
GENERAL MARKET		2 OF 7	

molex

QSFP-DD 1X5 GANGED CAGE ASSY
SF WITH FIN H/S OPTIONS

PRODUCT CUSTOMER DRAWING

DOCUMENT NUMBER	DOC TYPE	DOC PART	REVISION
2033711201	PSD	ASY	D3

PART NUMBER SELECTION

CLOSED TOP

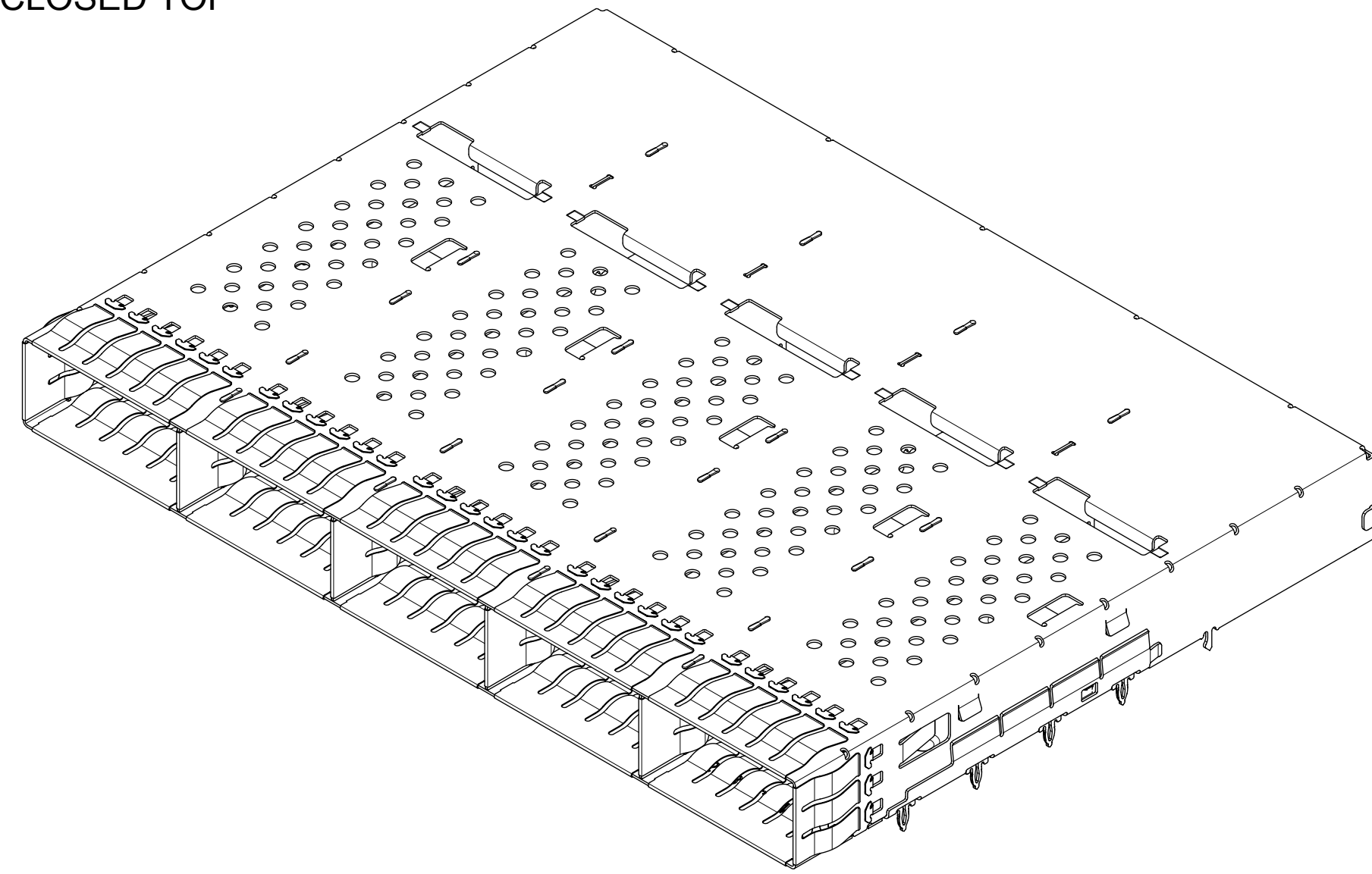

OPEN TOP

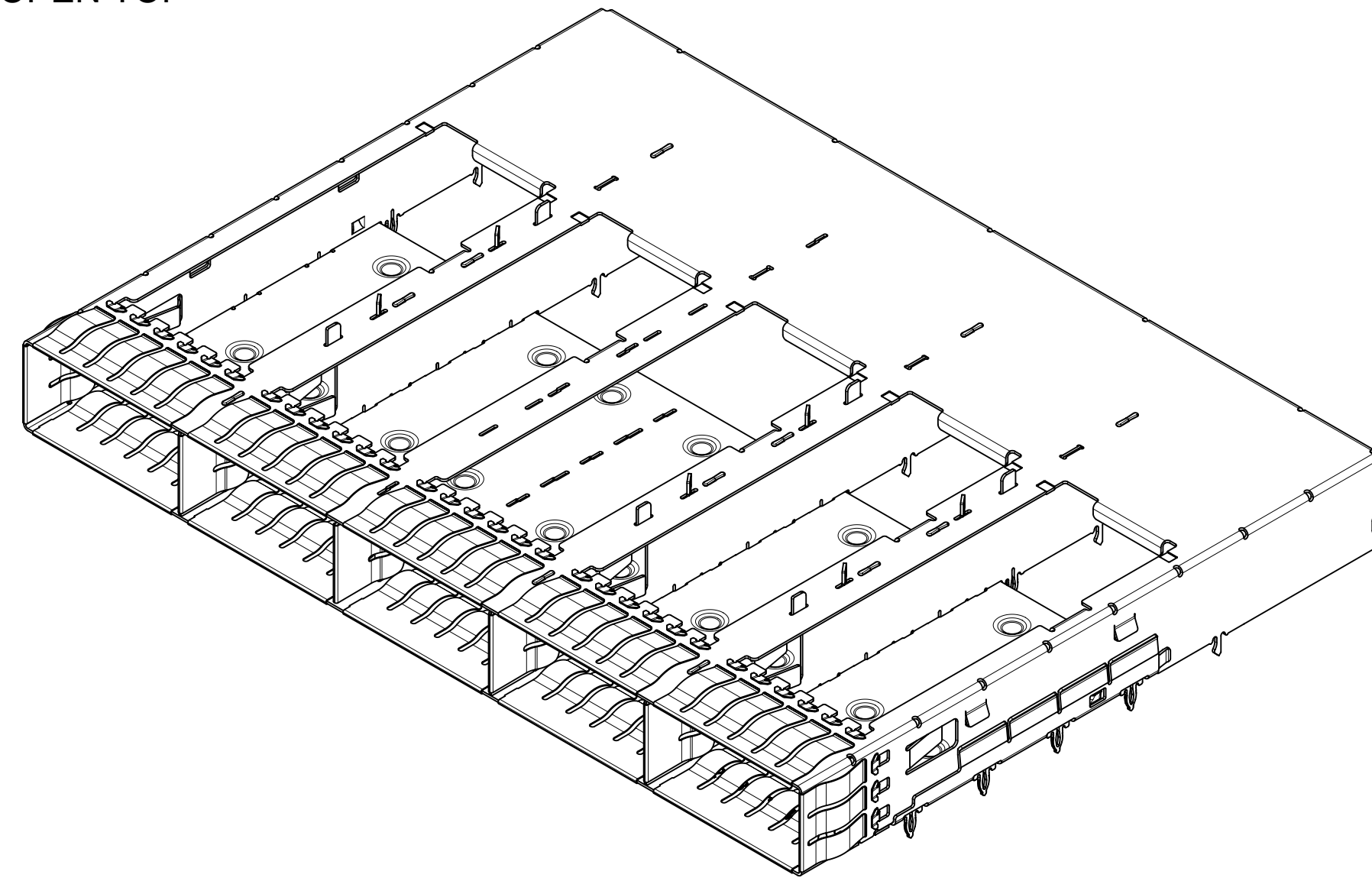

WITH HEAT SINK

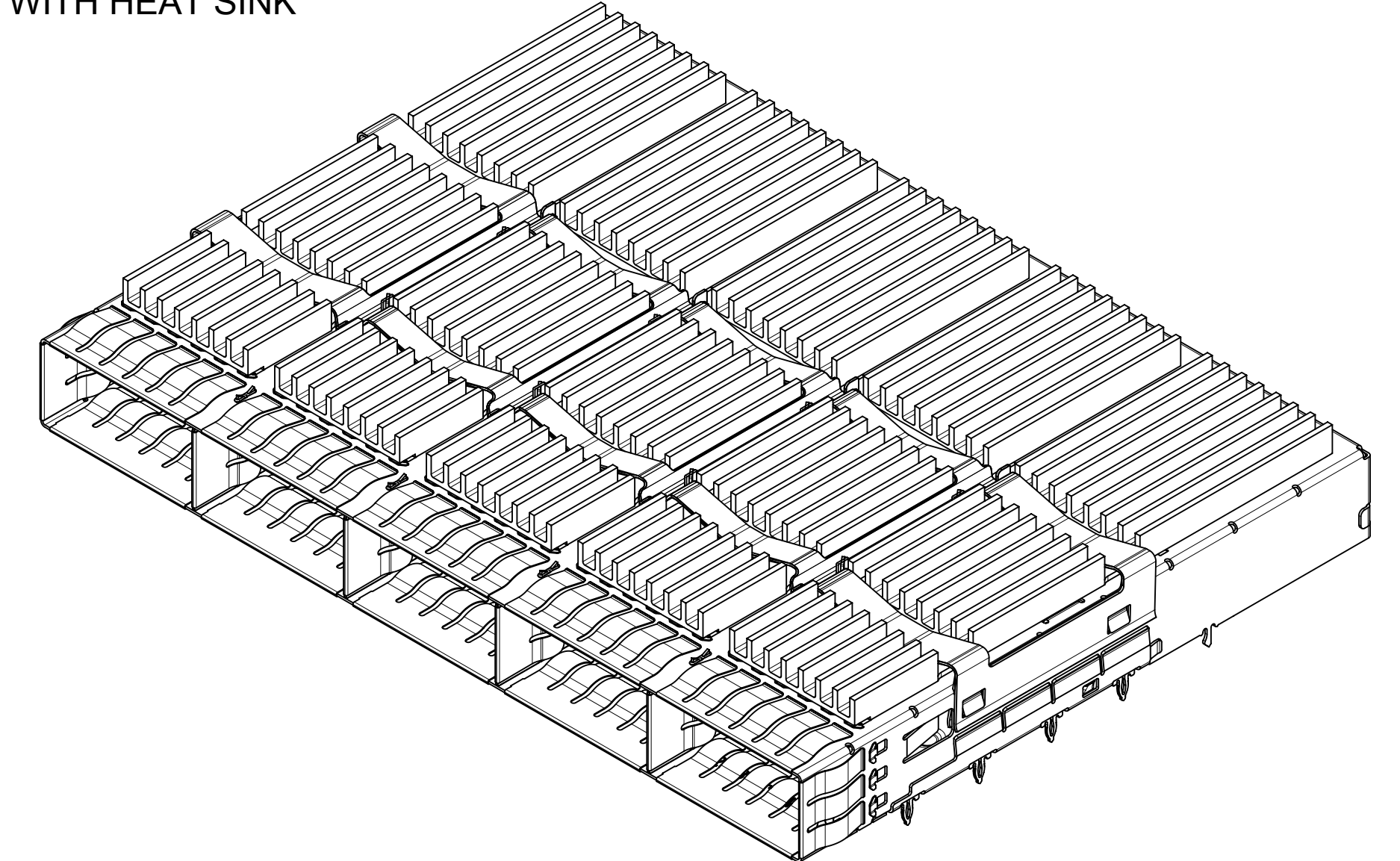

MOLEX P/N	# OF REAR LEGS PER PORT	WITH RAISED BASE
2033711243	0	NO
2033711244	1	NO

MOLEX P/N	# OF REAR LEGS PER PORT	WITH RAISED BASE
2033711253	0	NO
2033711254	1	NO
2033712253	0	YES
2033712254	1	YES

MOLEX P/N	HEAT SINK	# OF REAR LEGS PER PORT	WITH RAISED BASE
2033711346	PCI	0	NO
2033711347	SAN	0	NO
2033711348	NET	0	NO
2033711349	PCI	1	NO
2033711350	SAN	1	NO
2033711351	NET	1	NO
2033712346	PCI	0	YES
2033712347	SAN	0	YES
2033712348	NET	0	YES
2033712349	PCI	1	YES
2033712350	SAN	1	YES
2033712351	NET	1	YES

RAISED BASE OPTIONS

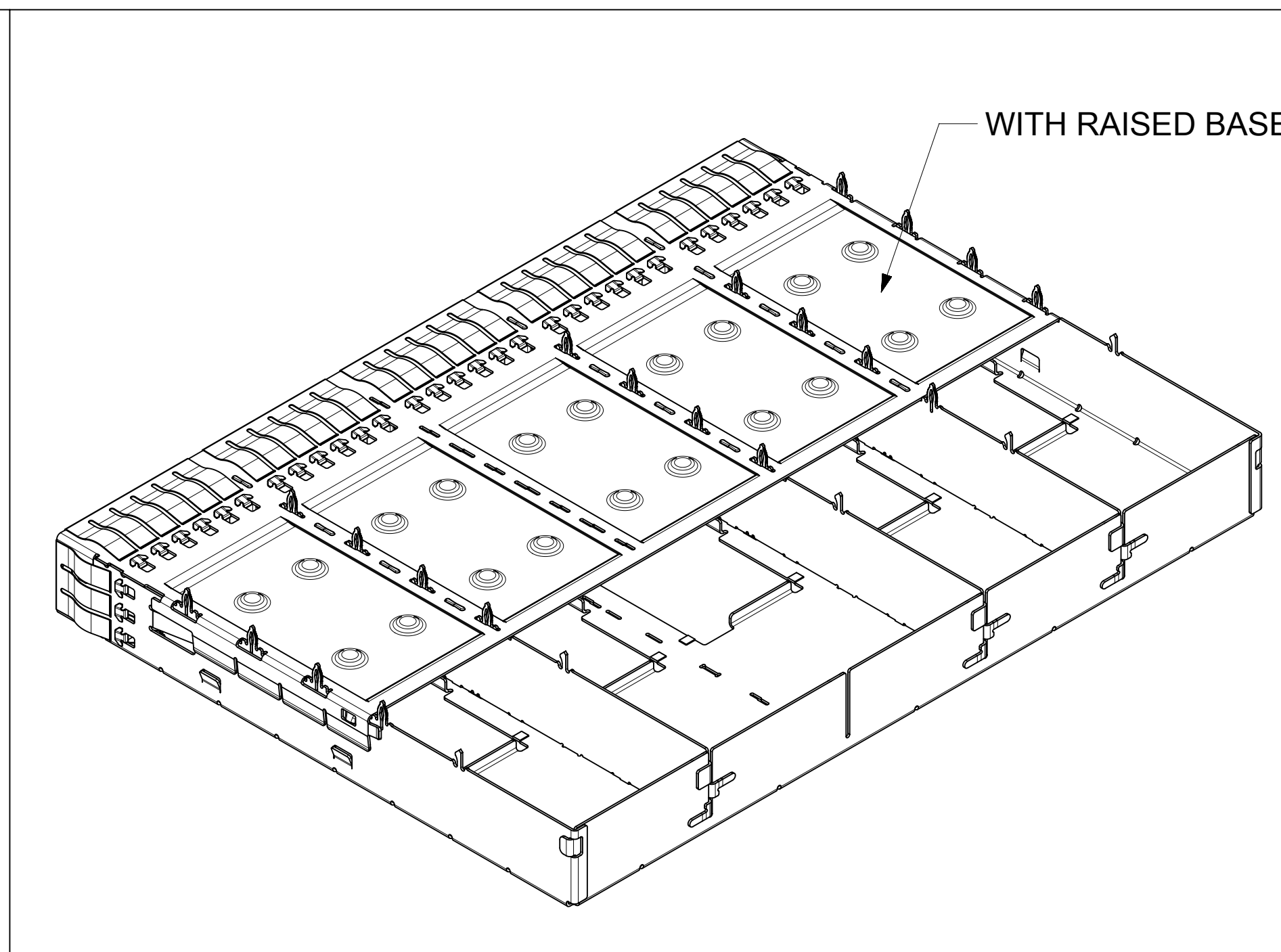
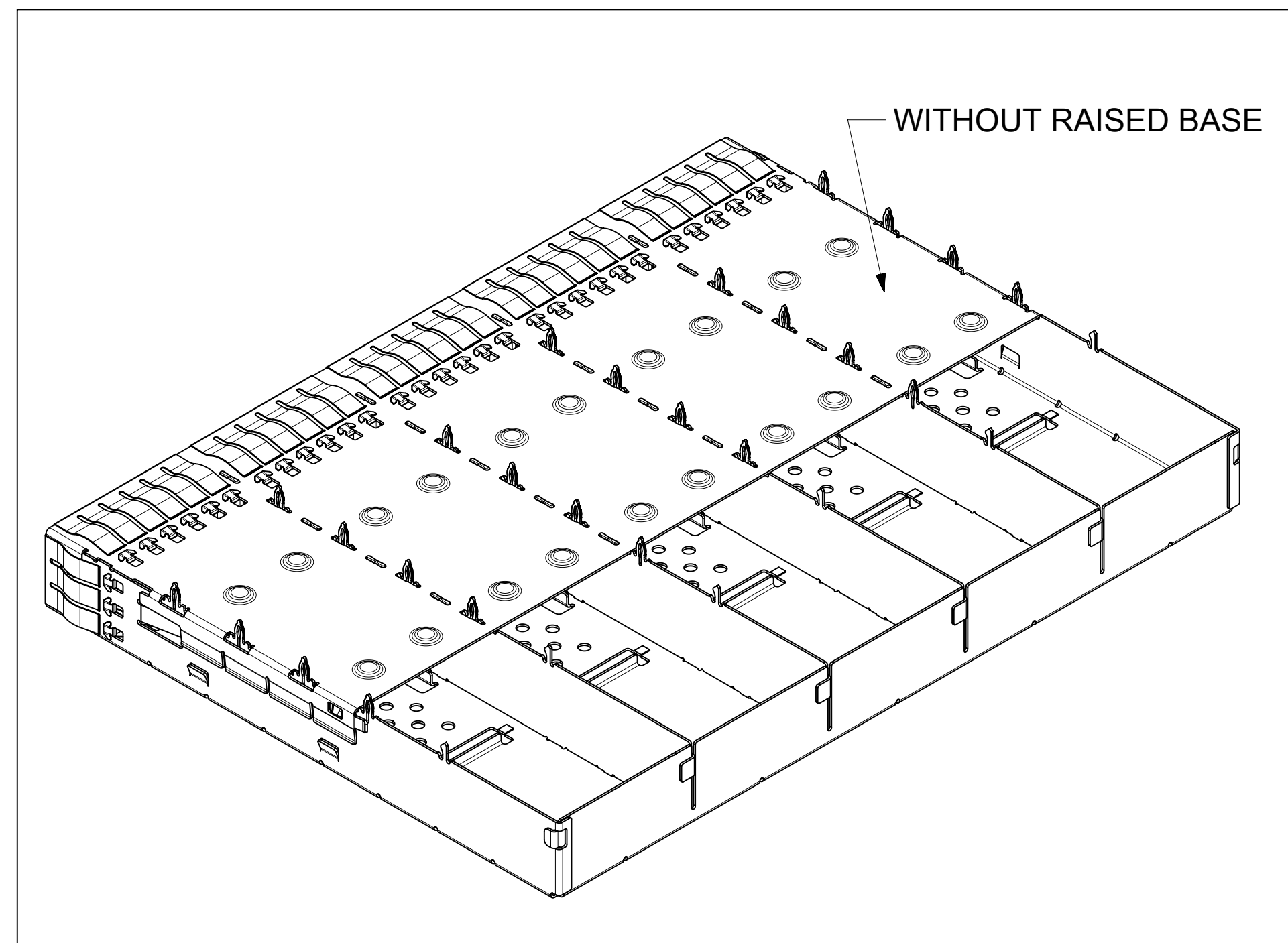

THIS DRAWING CONTAINS INFORMATION THAT IS PROPRIETARY TO MOLEX ELECTRONIC TECHNOLOGIES, LLC AND SHOULD NOT BE USED WITHOUT WRITTEN PERMISSION											
DIMENSION UNITS		SCALE		CURRENT REV DESC: SEE REVISION TABLE							
mm		2:1		<div style="text-align: center;">molex</div> QSFP-DD 1X5 GANGED CAGE ASSY SF WITH FIN H/S OPTIONS PRODUCT CUSTOMER DRAWING							
GENERAL TOLERANCES (UNLESS SPECIFIED)											
ANGULAR TOL ± 2.0°											
4 PLACES ±											
3 PLACES ±											
2 PLACES ± 0.13											
1 PLACE ± 0.25				EC NO: 629406 DRWN: JYEN01 2019/12/13 CHK'D: SCHIEN 2019/12/20 APPR: JCHIANG 2019/12/20				DOCUMENT NUMBER 2033711201			
0 PLACES ±				INITIAL REVISION: DRWN: MKEMPEGOWDA 2017/07/24 APPR: RCHEN08 2017/08/15				DOC TYPE DOC PART REVISION PSD ASY D3			
DRAFT WHERE APPLICABLE MUST REMAIN WITHIN DIMENSIONS		THIRD ANGLE PROJECTION		DRAWING		SERIES		MATERIAL NUMBER		CUSTOMER	
				D-SIZE		203371		GENERAL MARKET		SHEET NUMBER	
										7 OF 7	

PCB LAYOUT FOR SINGLE SIDED MOUNTING

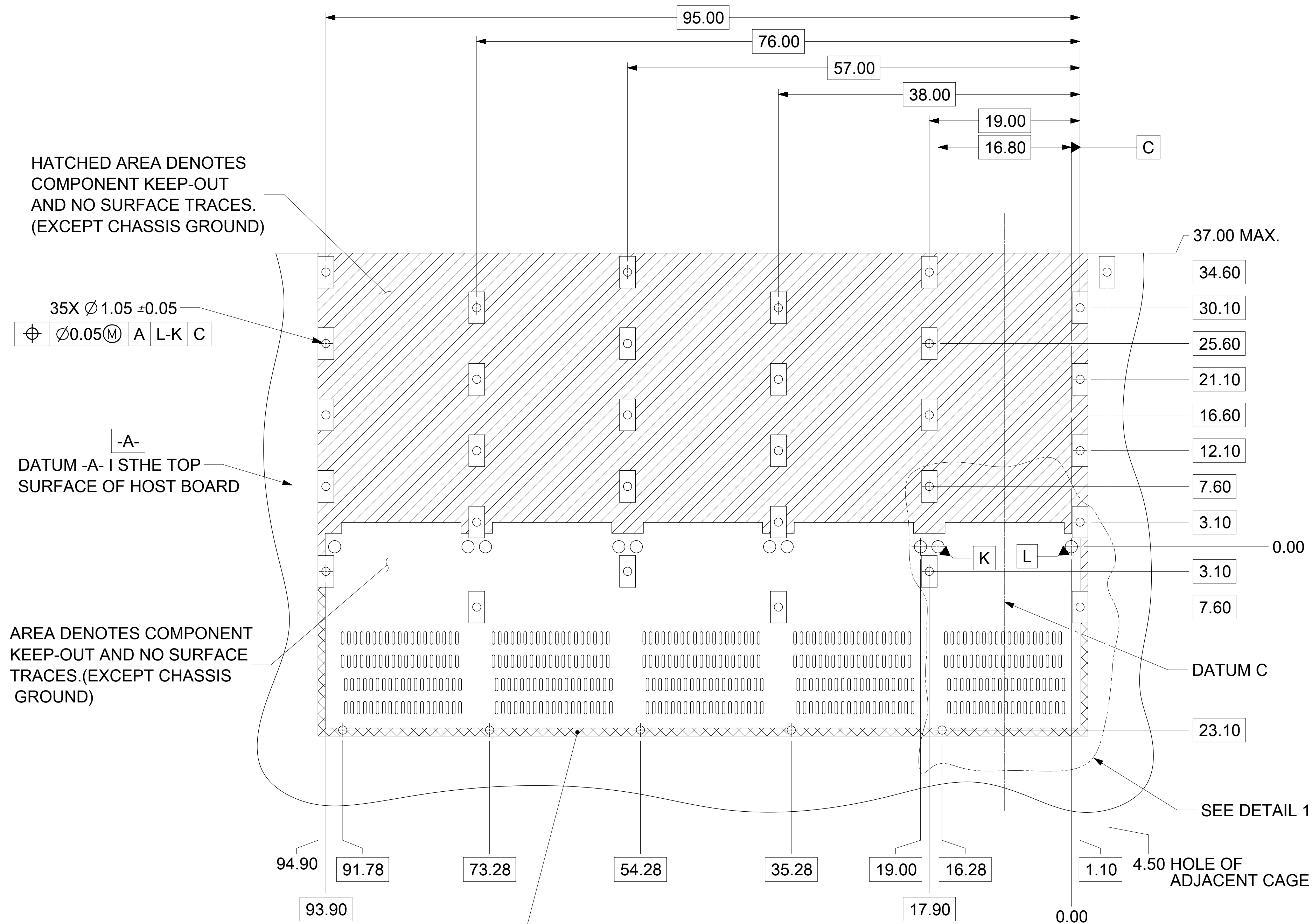

HATCHED AREA DENOTES COMPONENT KEEP-OUT AND NO SURFACE TRACES. (EXCEPT CHASSIS GROUND)

35X $\varnothing 1.05 \pm 0.05$
 $\varnothing 0.05$ (M) A L-K C

DATUM -A- IS THE TOP SURFACE OF HOST BOARD

CROSS HATCHED AREA DENOTES COMPONENT KEEP-OUT AND NO SURFACE TRACES. (EXCEPT CHASSIS GROUND)

CROSS HATCHED AREA DENOTES COMPONENT KEEP-OUT AND NO SURFACE TRACES. (EXCEPT FOR CHASSIS GROUND)

HOST CONNECTOR DETAIL

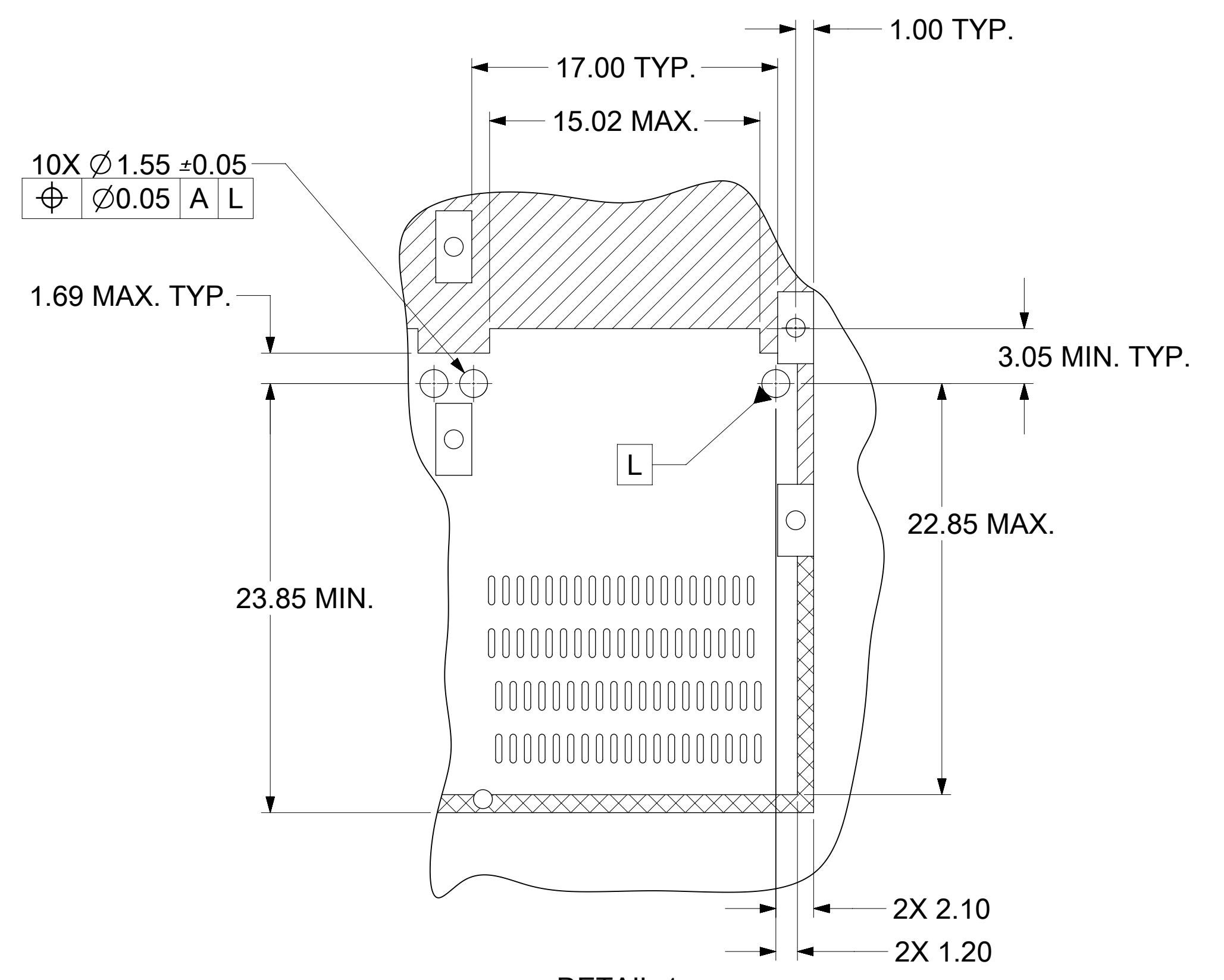

DETAIL 1
SCALE 4:1

NO REAR LEGS

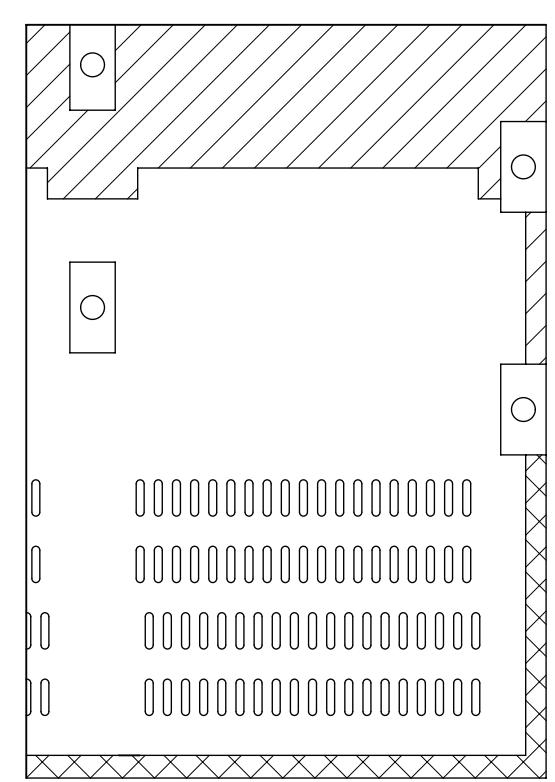

PARTIAL 1

- NOTES:
- PADS AND VIAS GO TO CHASSIS GROUND. (RECOMMENDED PADS TO BE 2.00x4.00mm RECTANGLE.)
 - RECOMMENDED THRU HOLE PLATING INCLUDES HASL, OSP, OR IMMERSION (GOLD, SILVER, OR TIN).
 - CONNECTOR PAD LAYOUT PER QSFP-DD MSA WILL ACCOMODATE MOLEX CONNECTOR SERIES 202718.

THIS DRAWING CONTAINS INFORMATION THAT IS PROPRIETARY TO MOLEX ELECTRONIC TECHNOLOGIES, LLC AND SHOULD NOT BE USED WITHOUT WRITTEN PERMISSION									
DIMENSION UNITS mm		SCALE 3:1		CURRENT REV DESC: SEE REVISION TABLE					
GENERAL TOLERANCES (UNLESS SPECIFIED)				EC NO: 629406					
ANGULAR TOL $\pm 2.0^\circ$				DRWN: JYEN01 2019/12/13					
4 PLACES \pm				CHK'D: SCHIEN 2019/12/20					
3 PLACES \pm				APPR: JCHIANG 2019/12/20					
2 PLACES ± 0.13				INITIAL REVISION:					
1 PLACE ± 0.25				DRWN: MKEMPEGOWDA 2017/07/24					
0 PLACES \pm				APPR: RCHEN08 2017/08/15					
DRAFT WHERE APPLICABLE MUST REMAIN WITHIN DIMENSIONS		THIRD ANGLE PROJECTION		DRAWING D-SIZE		SERIES 203371		MATERIAL NUMBER SEE P/N TABLE	
DOCUMENT STATUS P1		RELEASE DATE 2019/12/20 10:48:52		CUSTOMER GENERAL MARKET		DOCUMENT NUMBER 2033711201		DOC TYPE PSD	
						DOC PART ASY		REVISION D3	
								SHEET NUMBER 3 OF 7	

molex

QSFP-DD 1X5 GANGED CAGE ASSY
SF WITH FIN H/S OPTIONS

PRODUCT CUSTOMER DRAWING

PCB LAYOUT FOR BELLY TO BELLY MOUNTING

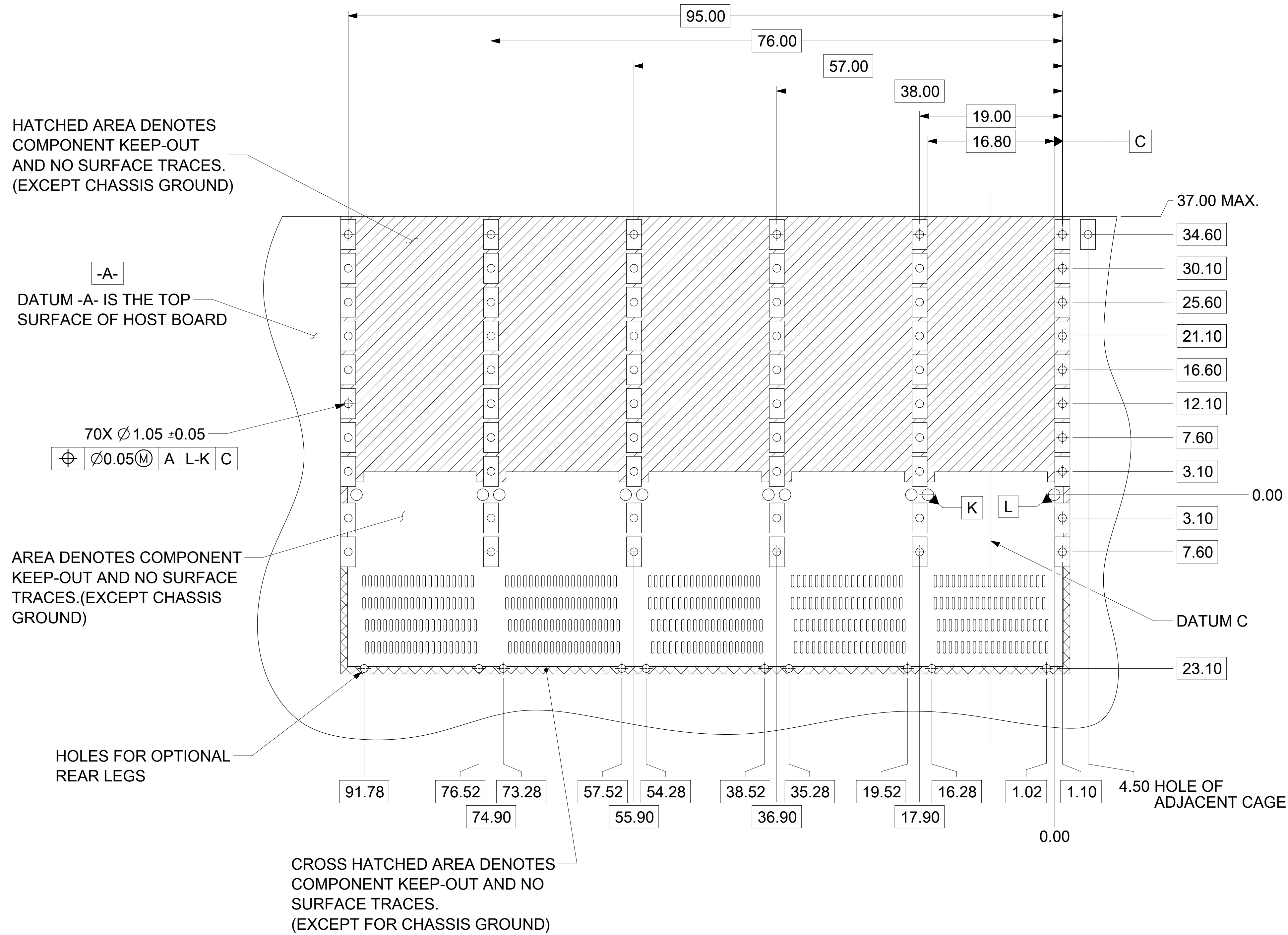

NOTE:
SEE SHEET 4 FOR
HOST CONNECTOR DETAIL

- NOTES:
1. PADS AND VIAS GO TO CHASSIS GROUND. (RECOMMENDED PADS TO BE 2.00x4.00mm RECTANGLE.)
 2. RECOMMENDED THRU HOLE PLATING INCLUDES HASL, OSP, OR IMMERSION (GOLD, SILVER, OR TIN).
 3. CONNECTOR PAD LAYOUT PER QSFP-DD WILL ACCOMODATE MOLEX CONNECTOR SERRIES 202718.

THIS DRAWING CONTAINS INFORMATION THAT IS PROPRIETARY TO MOLEX ELECTRONIC TECHNOLOGIES, LLC AND SHOULD NOT BE USED WITHOUT WRITTEN PERMISSION									
DIMENSION UNITS		SCALE		CURRENT REV DESC: SEE REVISION TABLE					
mm		3:1		<p>molex</p> <p>QSFP-DD 1X5 GANGED CAGE ASSY SF WITH FIN H/S OPTIONS</p> <p>PRODUCT CUSTOMER DRAWING</p> <p>DOCUMENT NUMBER: 2033711201 DOC TYPE: PSD DOC PART: ASY REVISION: D3</p> <p>MATERIAL NUMBER: SEE P/N TABLE CUSTOMER: GENERAL MARKET SHEET NUMBER: 4 OF 7</p>					
GENERAL TOLERANCES (UNLESS SPECIFIED)									
ANGULAR TOL ± 2.0°									
4 PLACES ±									
3 PLACES ±									
2 PLACES ± 0.13									
1 PLACE ± 0.25									
0 PLACES ±				INITIAL REVISION:					
DRAFT WHERE APPLICABLE MUST REMAIN WITHIN DIMENSIONS		THIRD ANGLE PROJECTION		DRAWING		SERIES		MATERIAL NUMBER	
				D-SIZE		203371		SEE P/N TABLE	

BEZEL AND BOARD POSTION DIMENSIONS FOR BELLY TO BELLY MOUNTING

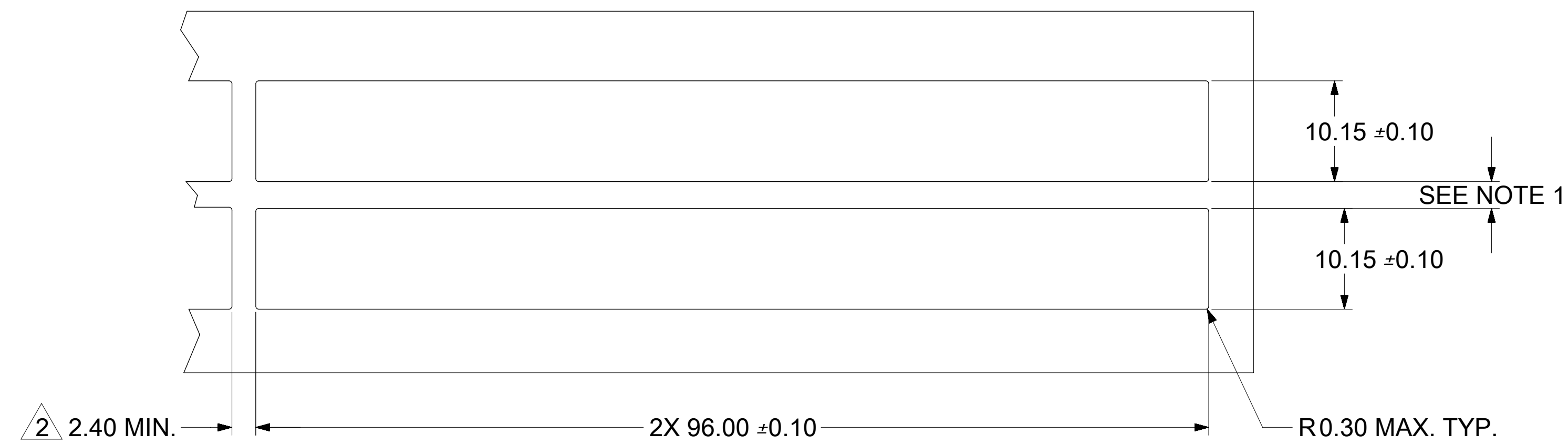
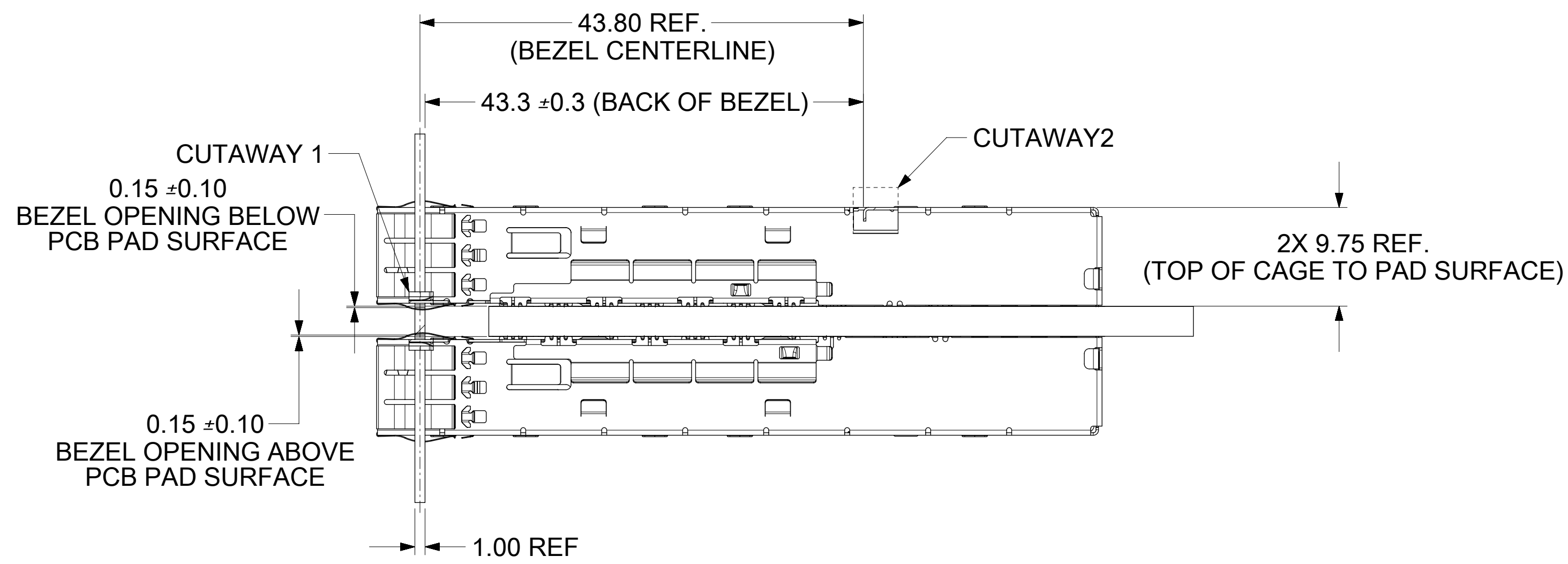

NOTE:
 1. PCB THICKNESS VARIATION MUST BE CONSIDERED WHEN DETERMINING BEZEL OPENING LOCATION.
 2. THIS DIMENSION IS FOR REFERENCE ONLY. USER CAN MODIFY IT DEPENDS ON APPLICATION.
 (THIS DIMENSION VARIES BASED ON DISTANCE OF "HOLE OF ADJACENT CAGE" ON PCB LAYOUT.)

BEZEL AND BOARD POSTION DIMENSIONS FOR SINGLE SIDE MOUNTING

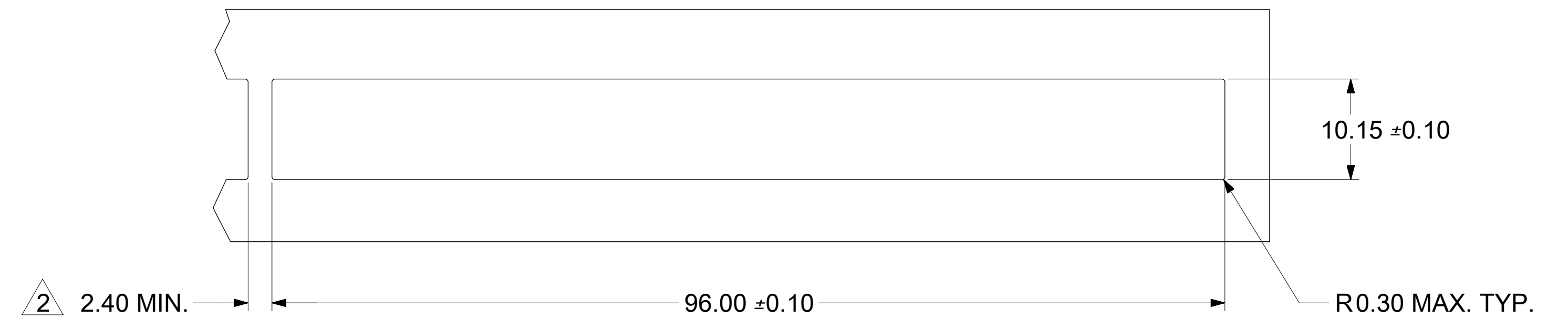
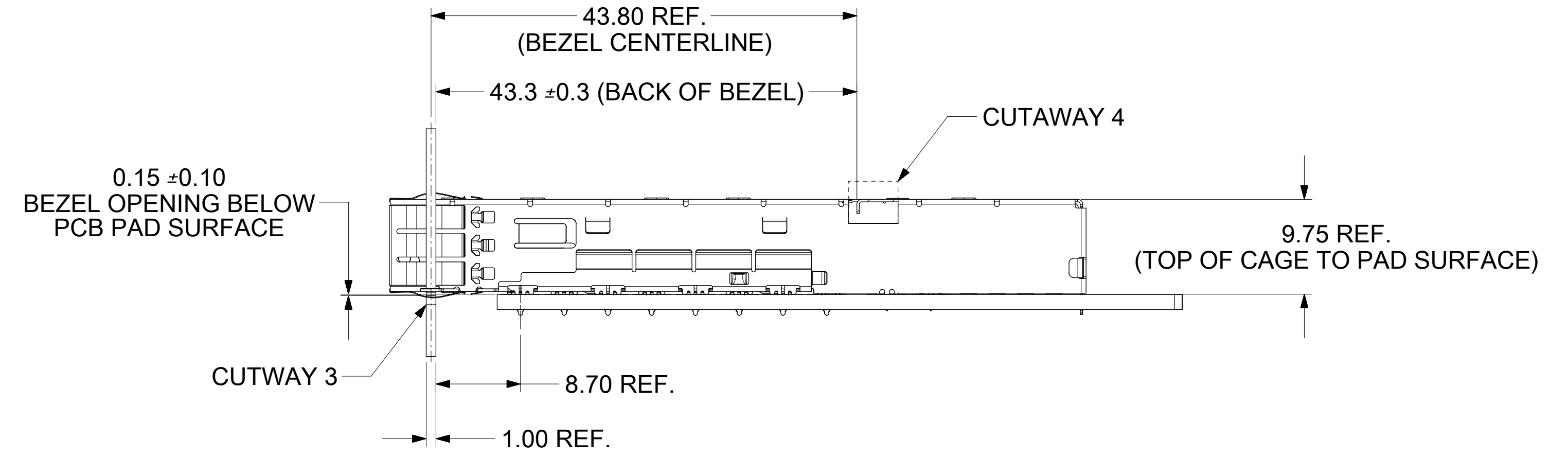

THIS DRAWING CONTAINS INFORMATION THAT IS PROPRIETARY TO MOLEX ELECTRONIC TECHNOLOGIES, LLC AND SHOULD NOT BE USED WITHOUT WRITTEN PERMISSION									
DIMENSION UNITS	SCALE	CURRENT REV DESC: SEE REVISION TABLE							
mm	2.5:1	<div style="text-align: center;">molex</div> QSFP-DD 1X5 GANGED CAGE ASSY SF WITH FIN H/S OPTIONS PRODUCT CUSTOMER DRAWING							
GENERAL TOLERANCES (UNLESS SPECIFIED)									
ANGULAR TOL	± 2.0°								
4 PLACES	±								
3 PLACES	±								
2 PLACES	± 0.13								
1 PLACE	± 0.25	EC NO: 629406	2019/12/13		DOCUMENT NUMBER: 2033711201 DOC TYPE: PSD DOC PART: ASY REVISION: D3				
0 PLACES	±	DRWN: JYEN01	2019/12/20						
DRAFT WHERE APPLICABLE MUST REMAIN WITHIN DIMENSIONS		CHK'D: SCHIEN	2019/12/20						
THIRD ANGLE PROJECTION		DRAWING		SERIES	MATERIAL NUMBER		CUSTOMER		
		D-SIZE		203371	SEE P/N TABLE		GENERAL MARKET		
							SHEET NUMBER: 5 OF 7		

REV	DATE	DESCRIPTION
A	2017/07/25	INITIAL RELEASE
A1	2017/08/29	SHEET 3: G11: UPDATED OPEN TOP ISO VIEW.
A2	2017/09/27	MODIFIED THE DOCUMENT TYPE FROM RSD TO SD
B	2017/11/02	SHEET 4: H18: AS PER THE QSFP-DD MSA TO CORRECTED TP TOLERANCE FROM 0.1 TO 0.05mm. K07: AS PER THE QSFP-DD MSA TO ADDED TP TOLERANCE AS 0.05mm AND CHANGED 1.55REF. TO 1.55±0.05mm.. SHEET 5: G17: AS PER THE QSFP-DD MSA TO CORRECTED TP TOLERANCE FROM 0.1 TO 0.05mm.
C	2018/03/19	SHEET 1: K17: ADDED DIMENSION 76.85 REF. SHEET 2: D04: ADDED A BACK VIEW. SHEET 4: H18: CHANGED "TYP." TO "35X" OF DIMENSION 1.05mm. H18: UPDATED TRUE POSITION DATUM FROM A, K AND L TO A, L-K AND C. K11: AS PER THE QSFP-DD MSA TO ADDED BASIC DIMENSION 16.80 AND DATUM C. K07: CHANGED "TYP." TO "10X" OF DIMENSION 1.55mm. SHEET 5: G17: CHANGED "TYP." TO "70X" OF DIMENSION 1.05mm. G17: UPDATED TRUE POSITION DATUM FROM A, K AND L TO A, L-K AND C.
D	2019/05/02	OPEN TOP SERIES PRODUCT REALLOCATED TO DRAWING NUMBER 2033712201; SHEET 3 (C16) & SHEET 4 (D15) : UPDATE RECOMMEND PCB LAYOUT OF TRACE KEEP-OUT ZONE.
D1	2019/07/15	SHEET 3: ADDED NEW P/Ns(-2XXX, WITH RAISED BASE).
D2	2019/08/01	SHEET 3 : 5G : ADDED A COLUMN FOR TYPES OF HEAT SINK.
D3	2019/12/13	SHEET 6 : E2 & E12 : CHANGED R0.30 TYP. TO R0.30 MAX. TYP. SHEET 6 : H7 & H17 : CHANGED BEZEL THICKNESS FROM 1.60 REF. TO 1.00 REF. SHEET 6 : K6 & K16 : CHANGED FROM 43.0 ±0.3 TO 43.3 ±0.3 SHEET 6 : J7 : CHANGED FROM 8.40 REF. TO 8.70 REF.

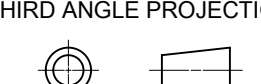
THIS DRAWING CONTAINS INFORMATION THAT IS PROPRIETARY TO MOLEX ELECTRONIC TECHNOLOGIES, LLC AND SHOULD NOT BE USED WITHOUT WRITTEN PERMISSION																	
DIMENSION UNITS	SCALE	CURRENT REV DESC: SEE REVISION TABLE															
mm	1:1	 <p>QSFP-DD 1X5 GANGED CAGE ASSY SF WITH FIN H/S OPTIONS</p> <p>PRODUCT CUSTOMER DRAWING</p>															
GENERAL TOLERANCES (UNLESS SPECIFIED)																	
ANGULAR TOL	± 2.0°																
4 PLACES	±																
3 PLACES	±																
2 PLACES	± 0.13																
1 PLACE	± 0.25	EC NO: 629406	DRWN: JYEN01		2019/12/13		<table border="1"> <tr> <td>DOCUMENT NUMBER</td> <td>DOC TYPE</td> <td>DOC PART</td> <td>REVISION</td> </tr> <tr> <td>2033711201</td> <td>PSD</td> <td>ASY</td> <td>D3</td> </tr> </table>			DOCUMENT NUMBER	DOC TYPE	DOC PART	REVISION	2033711201	PSD	ASY	D3
DOCUMENT NUMBER	DOC TYPE	DOC PART	REVISION														
2033711201	PSD	ASY	D3														
0 PLACES	±	INITIAL REVISION:	DRWN: MKEMPEGOWDA		2017/07/24												
DRAFT WHERE APPLICABLE MUST REMAIN WITHIN DIMENSIONS		THIRD ANGLE PROJECTION		DRAWING		SERIES											
				D-SIZE		203371		MATERIAL NUMBER									
						SEE P/N TABLE		CUSTOMER									
						GENERAL MARKET		SHEET NUMBER									
						6 OF 7											

DOCUMENT STATUS	P1	RELEASE DATE	2019/12/20	10:48:52
-----------------	----	--------------	------------	----------