

Consumer Grade Off Line Power Supply Surge Protection

Solution Products



ACTP250J1BJR-S



FW30A10R0JA

Objective

Metal Oxide Varistors provide protection for off line power converters from differential surges (2 Ω impedance) of greater than 2 kV. They clamp the incoming transient and reduce the peak current which stresses the diodes and bulk capacitor. Model ACTP250J1BJR-S is an SMB package device which can add an extra 135 Vrms to the rated voltage of the surge protection when placed in series with the MOV. This does not compromise the clamping voltage of the MOV. This is a solution for applications where swells in the AC voltage occur or where a reduction in surge current in the bulk capacitor is desired. For low power (less than 20 W), a UL listed fusible wirewound resistor, Model FW30A10R0JA, helps to attenuate surges and inrush currents as well as providing fuse protection from diodes shorting. For peak surge currents higher than 1K A, the Model ACTP250J1BJR-S should be replaced by a gas discharge tube such as the SA2 series.

Solution

- 1 AC Transient Protector ACTP250J1BJR-S
- 1 Fusible Resistor FW30A10R0JA

Compliance*

IEC 61000-4-5

Alternate Recommendations

- 1 High Voltage GDT
- 1 SA2-2400-CLB-STD

Benefit

A combination of Model ACTP250J1BJR-S and an MOV reduces the stress on diodes and capacitors compared with a single MOV of equal voltage rating. Does not compromise MOV clamping. No degradation of leakage current over time. Small form factor.

Design Kit



PN-DESIGNKIT-51

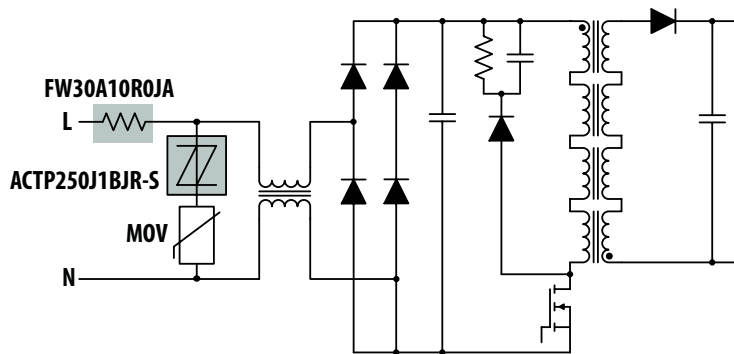

*The Bourns® Model ACTP250J1BJR-S has been tested to a 1K A surge current of a wave shape 8/20 μ s which is compliant with IEC 61000-4-5 specifications.

The schematic shown here illustrates the application protection and does not constitute the complete circuit design. Customers should verify actual device performance in their specific applications.