

## LTC3855EUJ

### DUAL OUTPUT

### SYNCHRONOUS BUCK CONVERTER

#### DESCRIPTION

Demonstration circuit DC1441A is a dual output synchronous buck converter featuring the LTC3855EUJ. The board provides two outputs of 1.8V/17A and 1.2V/17A from an input voltage of 4.5V to 14V at a switching frequency of 400kHz.

The demo board uses a high density, two sided drop-in layout. The power components, excluding the bulk output and input capacitors, fit within a 1.4" X 0.75" area on the top layer. The control circuit resides in a 0.8" X 0.9" area on the bottom layer. The package style for the LTC3855EUJ is a 40-lead 6mm X 6mm QFN.

The main features of the board are listed below:

- Differential amplifier for remote sensing  $V_{OUT2}$  which is configured for 1.2V.
- Diff amp bypass for  $V_{OUT2} \geq 3.3V$ .
- Optional resistors for single output dual phase operation.
- Optional resistors for DCR sensing and for NTC compensated DCR sensing.
- PLLIN pin for synchronization to an external clock which can be used in conjunction with PHASMD pin and CLKOUT pin for up to 12-phase operation.
- Selectable light load operating modes of pulse skip, Burst Mode® or FCM.
- TRACK/SS pins for external rail tracking.
- RUN pins and PGOOD pins for each phase.

**Design files for this circuit board are available. Call the LTC factory.**

**Table 1. Performance Summary ( $T_A = 25^\circ C$ )**

PARAMETER	CONDITION	VALUE
Minimum Input Voltage		4.5V
Maximum Input Voltage		14V
Output Voltage $V_{OUT1}$	$I_{OUT1} = 0A$ TO 17A, $V_{IN} = 4.5V$ to 14V	$1.8V \pm 1.75\%$
Output Voltage $V_{OUT2}$	$I_{OUT2} = 0A$ TO 17A, $V_{IN} = 4.5V$ to 14V	$1.2V \pm 1.50\%$
Nominal Switching Frequency		400kHz
Efficiency	$V_{OUT1} = 1.8V$ , $I_{OUT1} = 17A$ , $V_{IN} = 12V$	88.3% typical
See Figures 3-5	$V_{OUT2} = 1.2V$ , $I_{OUT2} = 17A$ , $V_{IN} = 12V$	85.0% typical

## QUICK START PROCEDURE

Demonstration circuit 1441 is easy to set up to evaluate the performance of the LTC3855EUJ. Refer to Figure 1 for the proper measurement equipment setup and follow the procedure below:

1. Place jumpers in the following positions:  
**JP1 RUN1      ON**  
**JP2            RUN2      ON**  
**JP3 MODE      FCM**
2. With power off, connect the input power supply to VIN and GND. Turn on the power at the input and increase the input voltage to 4.5V or higher.
3. Check for the proper output voltages.  
Vout1 = 1.769V to 1.832V  
Vout2 = 1.182V to 1.218V
4. Once the proper output voltages are established, adjust the loads within the operating range and observe the output voltage regulation, ripple voltage, efficiency and other parameters.

**Note 1.** Do not apply load between the VO1+ and VO1- pins or between the VO2\_SNS+ and VO2\_SNS- pins. These pins are only intended to Kelvin sense the output voltage across COUT1 and COUT4. Heavy load currents applied across the VO1+/- sense pins will damage these sense traces. Heavy load currents across the VO2\_SNS+/- pins will damage the converter.

**Note 2.** When measuring the output or input voltage ripple, do not use the long ground lead on the oscilloscope probe. See Figure 2 for the proper scope probe technique. Short, stiff leads need to be soldered to the (+) and (-) terminals of an output capacitor. The probe's ground ring needs to touch the (-) lead and the probe tip needs to touch the (+) lead.

## SINGLE OUTPUT / DUAL PHASE OPERATION

A single output / dual phase converter may be preferred for high output current applications. The benefits of single output / dual phase operation is lower ripple current through the input and output capacitors, improved load step response and simplified thermal design. To implement single output / dual phase operation, make the following modifications:

- Tie VOUT1 to VOUT2 by tying together the exposed copper pads on the VOUT shapes with pieces of heavy copper foil.
  - Tie ITH1 to ITH2 by stuffing 0Ω at R49.
  - Tie VFB1 to VFB2 by stuffing 0Ω at R50.
  - Tie TRK/SS1 to TRK/SS2 by stuffing 0Ω at R52.
  - Tie RUN1 to RUN2 by stuffing 0Ω at R55.
  - Keep the ILIM pins at the same potential or tie them together by stuffing 0Ω at R71.
- Keep the ITEMP pins at the same potential or tie them together by stuffing 0Ω at R67.
  - Remove the redundant ITH compensation network, VFB divider and TRACK/SS cap.
  - Re-compensate if necessary.

## INDUCTOR DCR SENSING

Demonstration circuit 1441 provides an optional circuit for DCR sensing. DCR sensing uses the DCR of the inductor to sense the inductor current instead of discrete sense resistors. The advantages of DCR sensing are lower cost, reduced board space and higher efficiency, but the disadvantage is a less accurate current limit. If DCR sensing is used, be sure to select an inductor current with a sufficiently high saturation current since the controller can not detect saturation when DCR sensing is used. This means using a ferrite with a high saturation current rating or using an iron powder type whose inductance will drop off much more gradually. Refer to tables 2 and 3 to see an example of how to setup the two rails for DCR sensing. The original  $R_{SENSE}$  setup is shown for comparison.

These parameters are used:

- $V_{OUT1} = 1.8V / 17A$
- $V_{OUT2} = 1.2V / 17A$
- $V_{IN} = 12V$
- $F_{SW} = 400kHz$ , typical
- $L_{1,2} = Vishay IHL4040DZ-01 0.56\mu H$
- (0.56 $\mu H$ , DCR = 1.7m $\Omega$  typ, 1.8m $\Omega$  max)
- $I_{LIM} = FLOATING$
- No temperature compensation

The DC1441A also has footprints for an NTC compensation network on the ITEMP pins for DCR sensing which increases the current sense threshold as the inductor temperature increases. As a result, the current limit falls less with temperature. RN1 detects the temperature for L1, RN2 detects the temperature for L2. RN3 is used for single output dual phase applications and is placed next to both inductors. See the data sheet for more details on NTC compensated DCR sensing.

## VOUT2 >= 3.3V

The 1.2V output on phase 2 uses the internal differential amplifier to sense the output voltage. However, its common mode range only goes up to 3.5V. Therefore, for margin, the nominal output voltage should not exceed 3.3V. For outputs of 3.3V and higher, the diff amp should be bypassed. To bypass the diff amp, follow these steps:

- Remove R11 to disconnect the output of the diff amp from the feedback divider.
- Stuff R12 with 0  $\Omega$  to tie the feedback divider to VOUT2 (through R65).
- Remove R70.
- Stuff R69 with 0  $\Omega$ .

# LTC3855EUJ

**Table 2.**  $V_{OUT1}$  Setup for 1.8V/17A with DCR Sensing and with Discrete Sense Resistors

CONFIGURATION	RS1	L1	RSENSE FILTER RESISTORS	SENSE FILTER CAP	DCR FILTER/DIVIDER RESISTORS		SENSE1- TO L1- JUMPER
					TOP	BOTTOM	
			<b>R29, R30</b>	<b>C14</b>	<b>R56</b>	<b>R57</b>	<b>R58</b>
DCR Sensing	Short with Cu strip or very short & thick piece of wire	Vishay IHL4040DZ-01 0.56uH Iron powder	Open	0.1uF	3.09k $\Omega$	100k $\Omega$	0 $\Omega$
Discrete R <sub>SENSE</sub> (original board)	2m $\Omega$ 2010 pkg	Vitec 59PR9875 0.4uH ferrite, Isat = 23A	100 $\Omega$	1nF	Open	Open	Open

**Table 3.**  $V_{OUT2}$  Setup for 1.2V/17A with DCR Sensing and with Discrete Sense Resistors

CONFIGURATION	RS2	L2	RSENSE FILTER RESISTORS	SENSE FILTER CAP	DCR FILTER/DIVIDER RESISTORS		SENSE2- TO L2- JUMPER
					TOP	BOTTOM	
			<b>R40, R39</b>	<b>C15</b>	<b>R59</b>	<b>R60</b>	<b>R62</b>
DCR Sensing	Short with Cu strip or very short & thick piece of wire	Vishay IHL4040DZ-01 0.56uH Iron powder	Open	0.1uF	3.09k $\Omega$	Not stuffed	0 $\Omega$
Discrete R <sub>SENSE</sub> (original board)	2m $\Omega$ 2010 pkg	Vitec 59PR9875 0.4uH ferrite, Isat = 23A	100 $\Omega$	1nF	Open	Open	Open

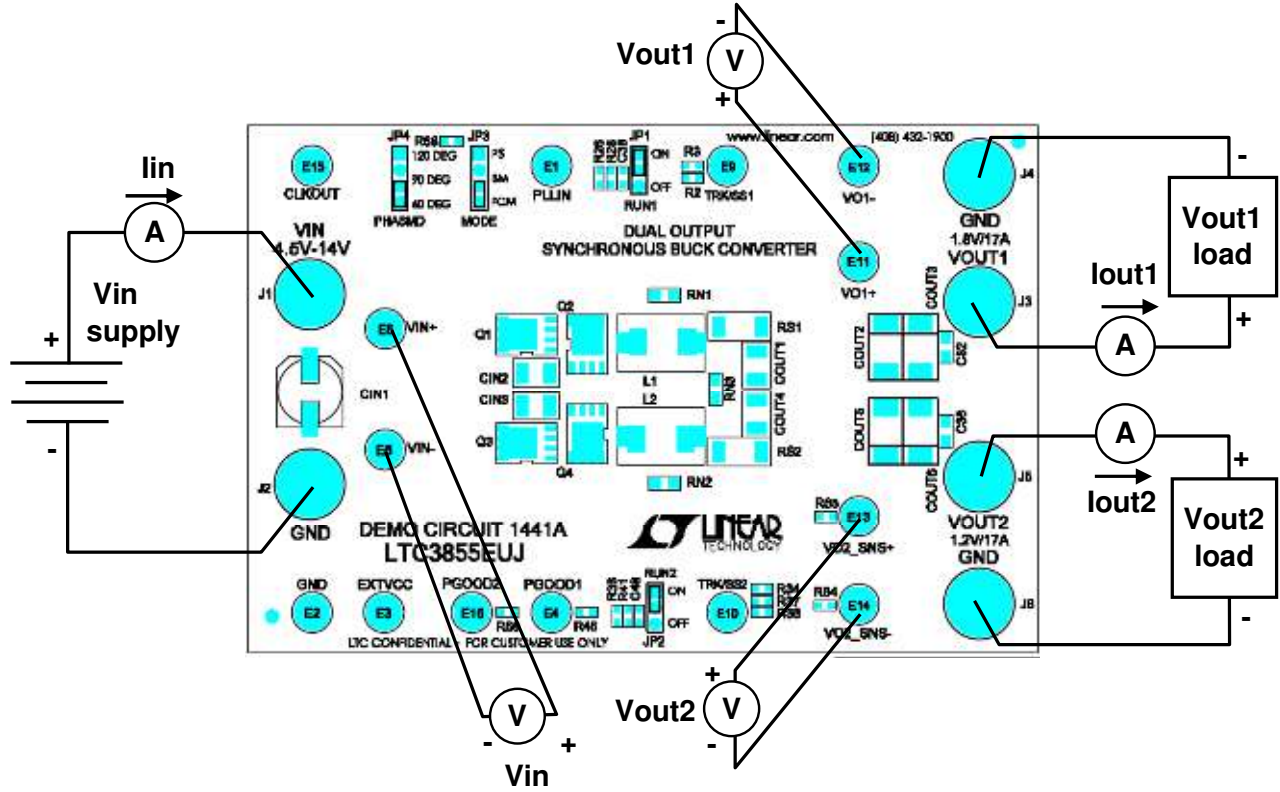

Figure 1. Proper Measurement Equipment Setup

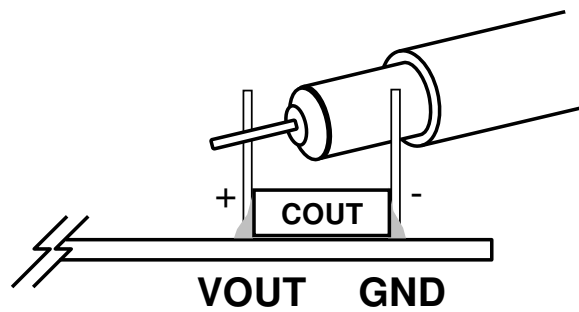

Figure 2. Measuring Output Voltage Ripple

**1.8V / 17A and 1.2V / 17A Efficiency**  
 at  $V_{IN} = 12V$ ,  $F_{SW} = 400kHz$ , mode = FCM

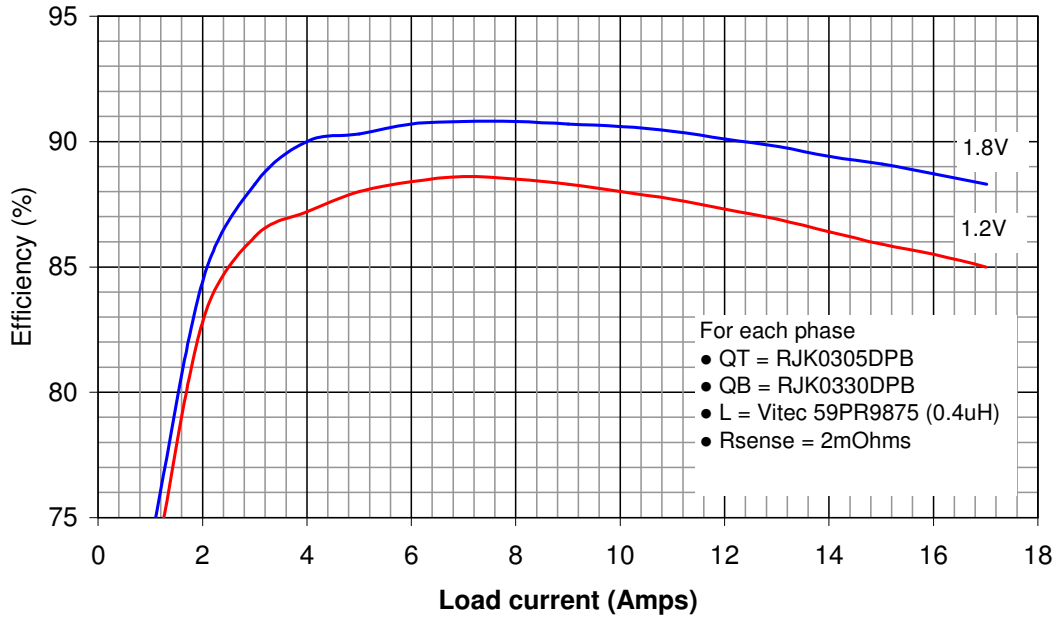

Figure 3. Typical Efficiency Curves in FCM

$V_{OUT} = 1.8V$ ,  $V_{IN} = 12V$ ,  $F_{SW} = 400kHz$

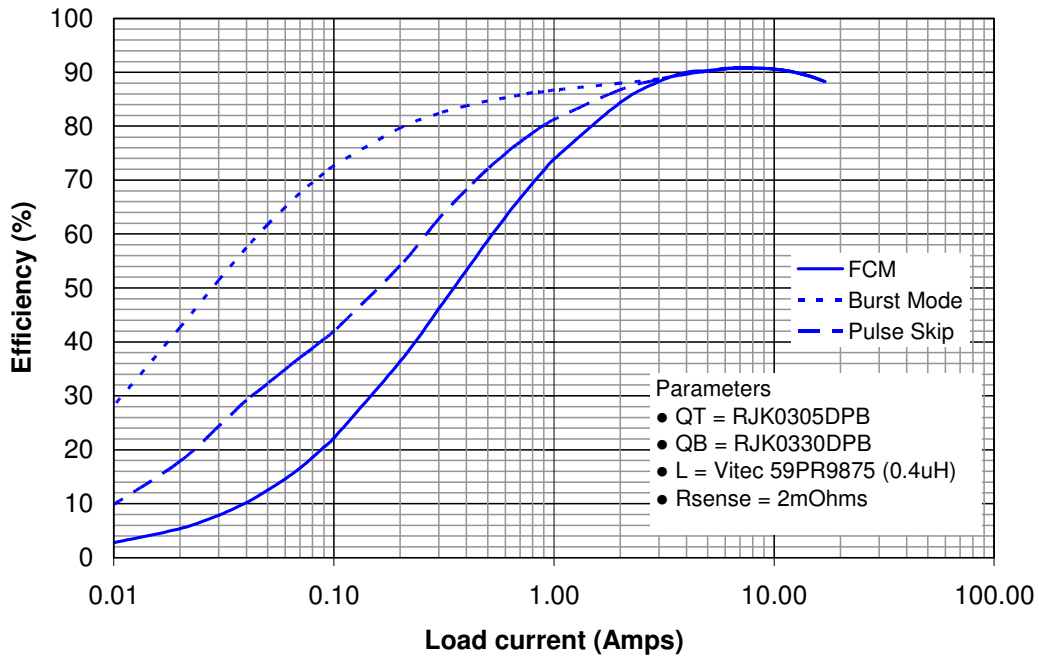

Figure 4. Typical Efficiency Curves for the 1.8V rail in FCM, Burst Mode and Pulse Skip Mode.

# LTC3855EUJ

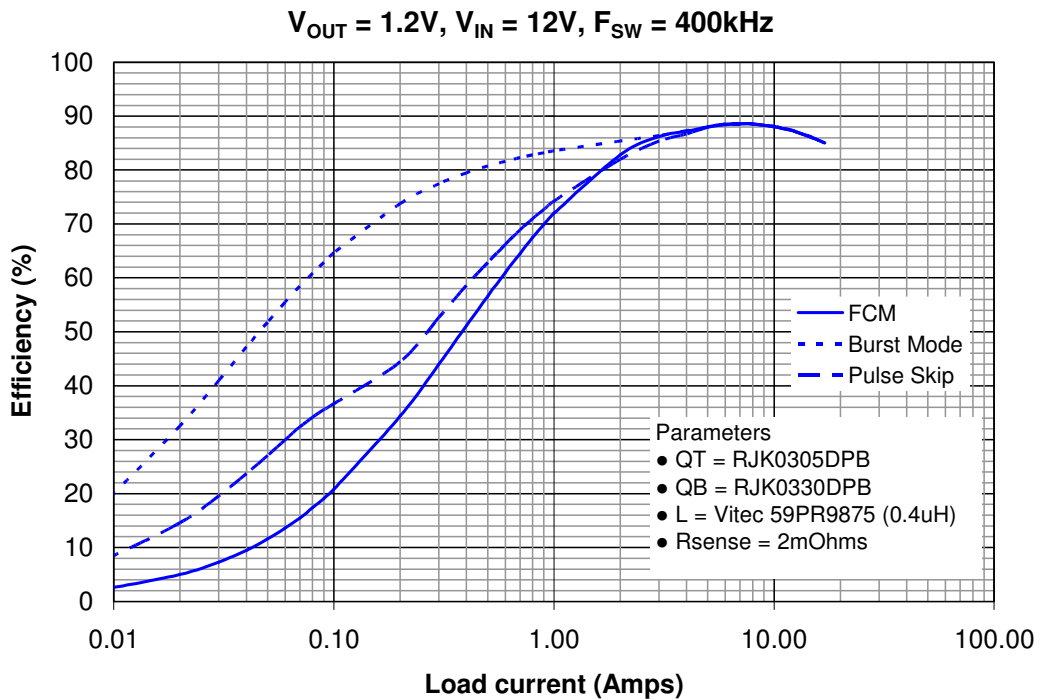
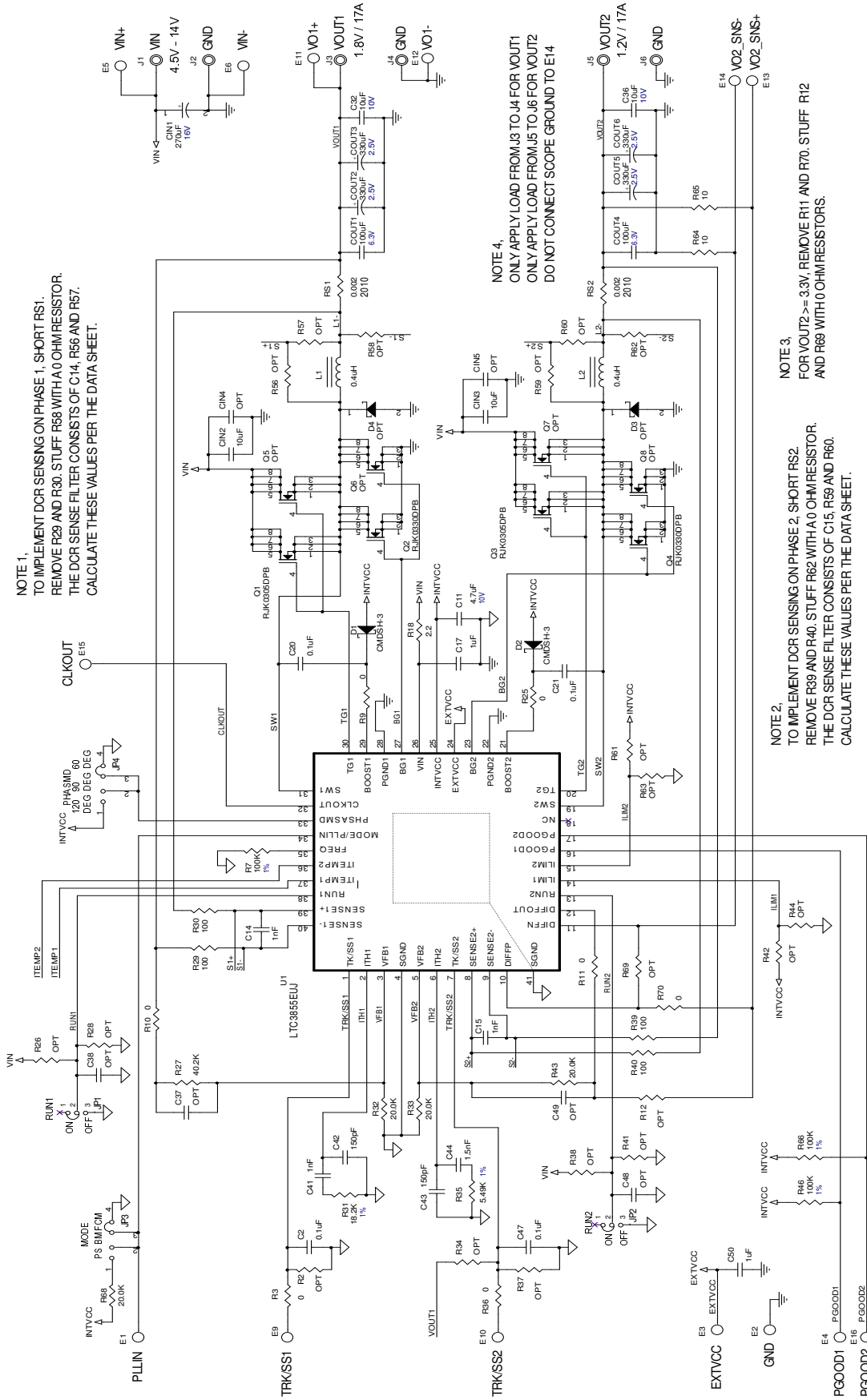

Figure 5. Typical Efficiency Curves for the 1.2V rail in FCM, Burst Mode and Pulse Skip Mode.

# LTC3855EUJ



**NOTE 1.**  
TO IMPLEMENT DCR SENSING ON PHASE 1, SHORT RS1.  
REMOVE R29 AND R30. STUFF R58 WITH A 0 OHM RESISTOR.  
THE DCR SENSE FILTER CONSISTS OF C14, R56 AND R57.  
CALCULATE THESE VALUES PER THE DATA SHEET.

**NOTE 4.**  
ONLY APPLY LOAD FROM J3 TO J4 FOR VOUT1  
ONLY APPLY LOAD FROM J5 TO J6 FOR VOUT2  
DO NOT CONNECT SCOPE GROUND TO E14

**NOTE 3.**  
FOR VOUT2 >= 3.3V, REMOVE R11 AND R70. STUFF R12  
AND R69 WITH 0 OHM RESISTORS.

**NOTE 2.**  
TO IMPLEMENT DCR SENSING ON PHASE 2, SHORT RS2.  
REMOVE R39 AND R40. STUFF R62 WITH A 0 OHM RESISTOR.  
THE DCR SENSE FILTER CONSISTS OF C15, R59 AND R60.  
CALCULATE THESE VALUES PER THE DATA SHEET.

