

RIGHT ANGLE BULKHEAD MALE RECEPTACLE

R114.673.020

REAR MONT FOR PCB SOLDER LEGS

Series : SMB

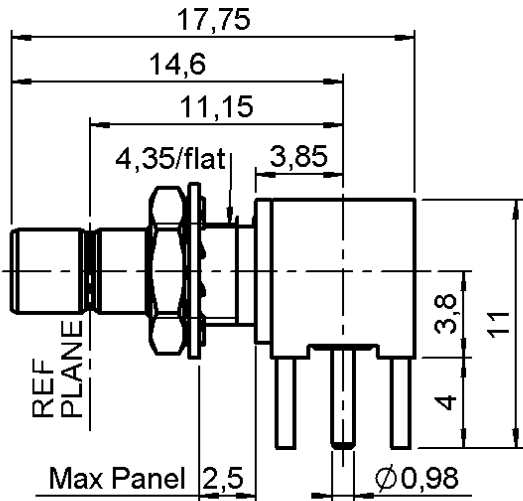
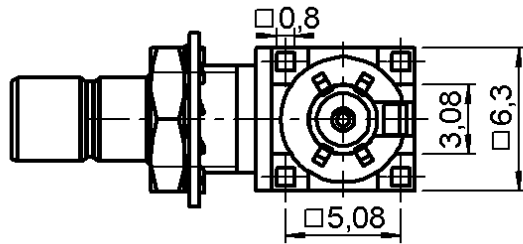

Scale : 3/1

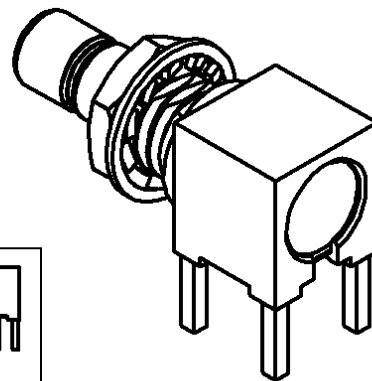

PANEL CUT OUT

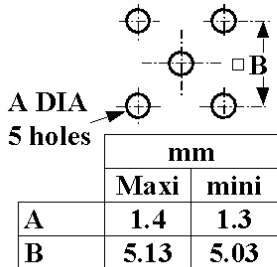

PANEL CUT OUT

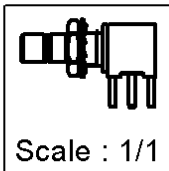
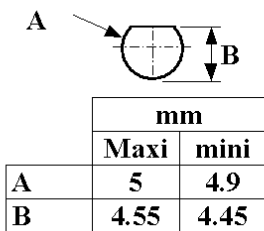

All dimensions are in mm.



COMPONENTS	MATERIALS	PLATINGS (µm)
BODY	BRASS	NICKEL 2
CENTER CONTACT	BERYLLIUM COPPER	GOLD 1.3 OVER NICKEL 2
OUTER CONTACT	-	-
INSULATOR	PTFE	-
GASKET	-	-
OTHERS PARTS	-	-
-	-	-
-	-	-

Issue : 0716 D

In the effort to improve our products, we reserve the right to make changes judged to be necessary.



RIGHT ANGLE BULKHEAD MALE RECEPTACLE

R114.673.020

REAR MONT FOR PCB SOLDER LEGS

Series : **SMB**

PACKAGING

SPECIFICATION

Standard	Unit	Other
1	-	Contact us

ELECTRICAL CHARACTERISTICS

Impedance	50	Ω
Frequency	0-4	GHz
VSWR	1.20* + 0,0000	x F(GHz) Maxi
Insertion loss	0.1*	$\sqrt{F(GHz)}$ dB Maxi
RF leakage	- (N/A)	- F(GHz)) dB Maxi
Voltage rating	335	Veff Maxi
Dielectric withstanding voltage	1000	Veff mini
Insulation resistance	1000	M Ω mini

ENVIRONMENTAL

Operating temperature	-65/+165	$^{\circ}$ C
Hermetic seal	NA	Atm.cm ³ /s
Panel leakage	NA	

OTHERS CHARACTERISTICS

Assembly instruction **NA**

Others :

* Coaxial Transmission Line Only

MECHANICAL CHARACTERISTICS

Center contact retention		
Axial force – Mating end	10	N mini
Axial force – Opposite end	10	N mini
Torque	NA	N.cm mini
Recommended torque		
Mating	NA	N.cm
Panel nut	60	N.cm
Mating life	500	Cycles mini
Weight	3,0000	g

Issue : **0716 D**

In the effort to improve our products, we reserve the right to make changes judged to be necessary.

