

REV.	DESCRIPTION	DATE	APPROVED
C	Engineering Update w/o Changes	02/25/04	M. C.
D	Material Update w/o Changes	05/13/05	M. C.
E	Added Pin Assembly Notes	01/16/09	T. Y.
F	Added Notes 4, 5, 6 & Color Options Sheet #2	05/16/16	J. C.

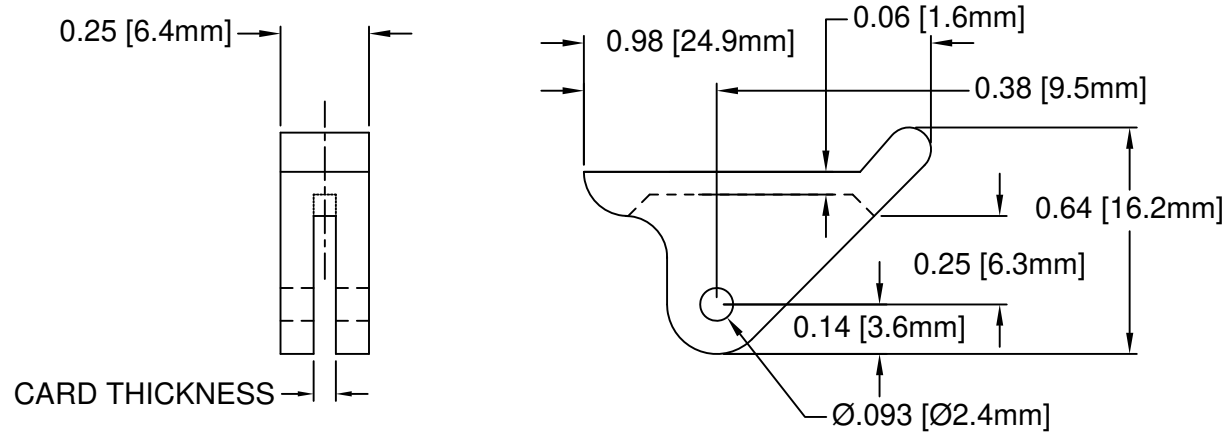

PART NO.	COLOR	ROLL PIN	CARD THICK.
CP-86 NT	NATURAL	RP-250	1/16"(1.6mm)
CP-86 WE	WHITE	RP-250	
CP-86 XX	SEE S.#2	RP-250	3/32"(2.4mm)
CP-89 NT	NATURAL	RP-250	
CP-89 WE	WHITE	RP-250	
CP-89 XX	SEE S.#2	RP-250	

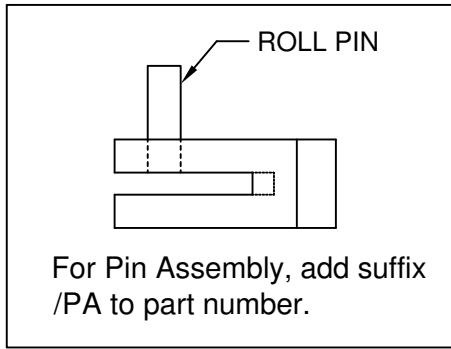
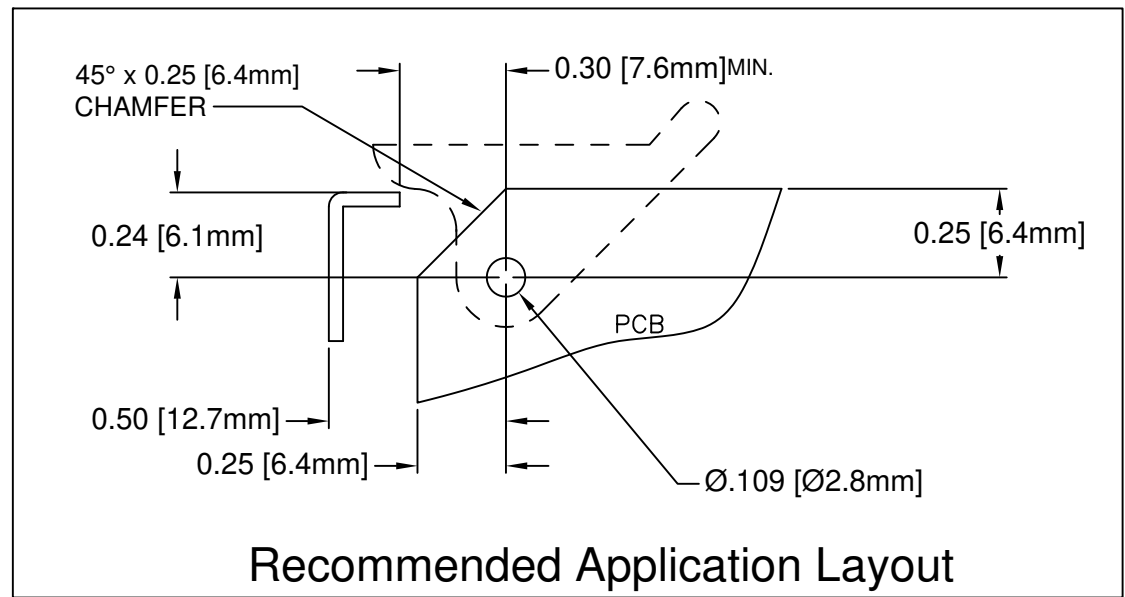

Recommended Application Layout

5. PRE-ASSEMBLED ROLL PINS AVAILABLE UPON REQUEST.
4. ROLL PINS INCLUDED. PACKAGED SEPARATELY.
3. MATERIAL: NYLON 6/6, 94V-2, WHITE.
2. MATERIAL: NYLON 6/6, 94V-2, NATURAL.
1. GENERAL SPECIFICATIONS: BIVAR MOLDED COMPONENT SPECIFICATION BV00-E101.

STANDARD TOLERANCE (UNLESS OTHERWISE SPECIFIED)		 4 THOMAS, IRVINE, CA. 92618 TEL: (949) 951-8808 FAX: (949) 951-3974	
DECIMALS	ANGULAR		
.X ± .1	X° ± 1°	 TITLE: PRINTED CIRCUIT BOARD EJECTOR	
.XX ± .01			
.XXX ± .005		PART NO: CP-8X	
DESIGNED: S. Irving	DATE: 05/13/98	REVISION: F	
CHECKED: D. Green	DATE: 12/04/02	CAGE CODE : 32559 SHEET # 1 OF 2	
CAD GENERATED DOCUMENT. DO NOT MEASURE DRAWING.			

OTHER AVAILABLE COLORS
 * SEE TABLE FOR ORDERING INFORMATION

REV.	DESCRIPTION	DATE	APPROVED
	SEE SHEET #1		

CP - 8 _

CP SERIES
CP-86
CP-89

ORDER CODE	COLOR
AA	AQUA
BK	BLACK
BE	BLUE
BN	BROWN
FG	FOREST GREEN
GY	GRAY
GN	GREEN
LE	LIME
OE	ORANGE
PK	PINK
RD	RED
VT	VIOLET
YW	YELLOW

6. PARTS ARE DYED TO COLOR UPON REQUEST.

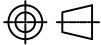
STANDARD TOLERANCE (UNLESS OTHERWISE SPECIFIED) DECIMALS ANGULAR		 4 THOMAS, IRVINE, CA. 92618 TEL: (949) 951-8808 FAX: (949) 951-3974	
		TITLE: PRINTED CIRCUIT BOARD EJECTOR	
DESIGNED: S. Irving	DATE: 05/13/98	PART NO: CP-8X	REVISION: F
CHECKED: D. Green	DATE: 12/04/02	CAGE CODE : 32559	SHEET # 2 OF 2
CAD GENERATED DOCUMENT. DO NOT MEASURE DRAWING.			