

PRODUCT NUMBER  
SEE TABLE

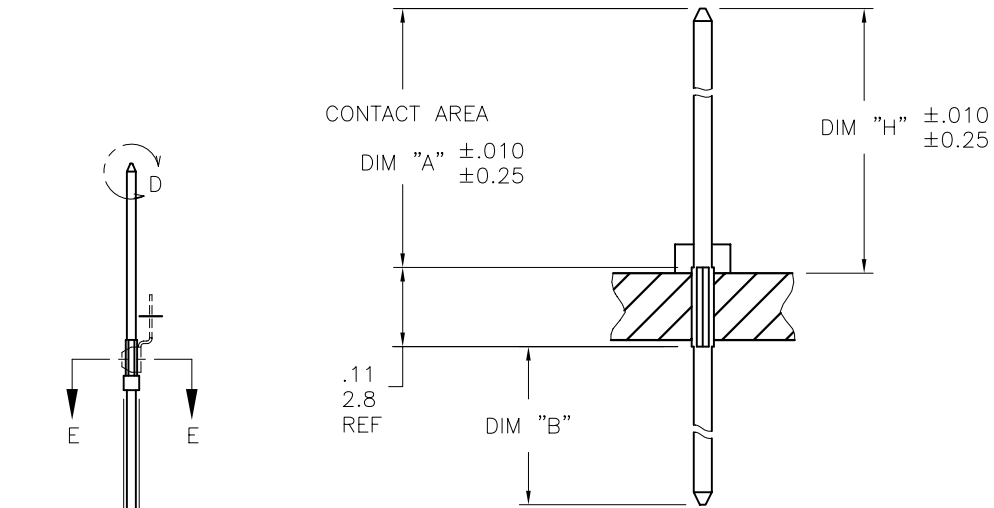

mat'l. code SEE NOTE 1				surface ASME Y14.5		tolerance ASME Y14.5		projection		product family PIN PRODUCTS	
ltr	ec'n no	dr	date	tolerances unless otherwise specified		tolerances unless otherwise specified		INCH/MM		title BERGPIN® .200"[5.08]cc .041"[1.04] DIA., .110"[2.79] LONG STAR WITH SOLDER WASHER	
A	V51002	MDF	1995-08-17	angles	XX*01/X*3	angles	XX*01/X*3	scale 2:1		dwg no sheet 1 of 3 size	
B	V51067	MDF	1995-10-03	flat	XXX*005/XXX*13	flat	XXX*005/XXX*13	FCI		71258 A4	
C	V61411	EPK	1996-11-14	0°±2'	XXXX*0020/XXX*051	0°±2'	XXXX*0020/XXX*051	type		CUSTOMER Drawing	
D	V92858	DLW	1999-08-30	dr	M. FETROW	dr	M. FETROW	sheet		1 of 3	
E	V06-0682	JRV	2006-07-18	engr	L. FYE	engr	L. FYE	type		CUSTOMER Drawing	
F	V08-0354	HTB	2008-08-20	chr	L. FYE	chr	L. FYE	sheet		1 of 3	
				appd	L. FYE	appd	L. FYE	type		CUSTOMER Drawing	
sheet	revision	F	F	F				sheet		1 of 3	
index	sheet	1	2	3				type		CUSTOMER Drawing	

PRODUCT NUMBER  
SEE TABLE

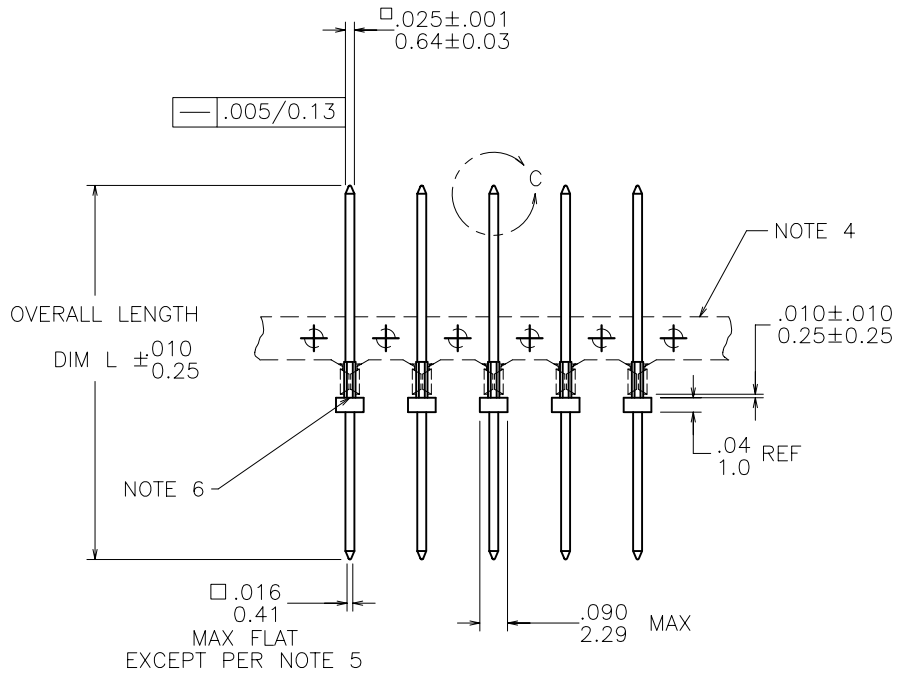
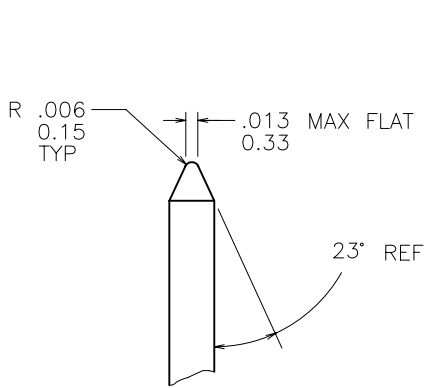

TRIM  
DETAIL C  
TYP BOTH ENDS

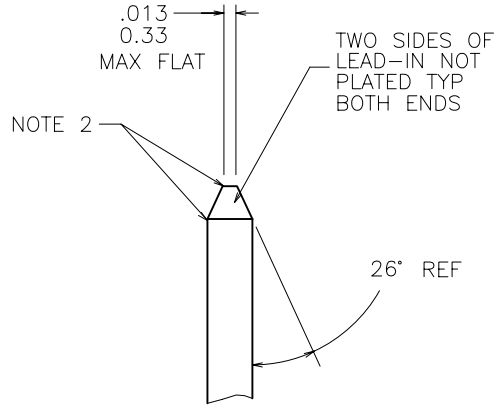

SWEDGE  
DETAIL D  
TYP BOTH ENDS

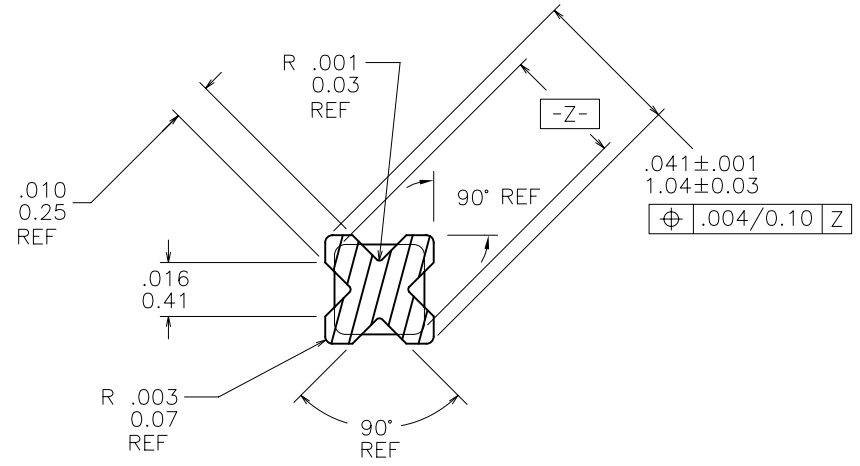

SECTION E-E  
SCALE 2:1  
(FERRULE REMOVED)

mat'l. code SEE NOTE 1		surface ASME Y14.5	tolerance ASME Y14.5	projection 	product family PIN PRODUCTS
ltr	ec'n no	dr	date	tolerances unless otherwise specified	title BERGPIN® .200"[5.08]cc .041"[1.04] DIA., .110"[2.79] LONG STAR WITH SOLDER WASHER
F				angles XX+01/XX+3 XXX+005/XXX+13	INCH/MM
				0'±2'	scale 1:1
		dr	M. FETROW	1995-08-17	dwg no
		engr	L. FYE	1995-08-17	sheet 2 of 3
		chr	L. FYE	1995-08-17	size
		appd	L. FYE	1995-08-17	71258
sheet index	revision sheet				type CUSTOMER Drawing



PRODUCT NUMBER	CONTACT AREA DIM A	TERMINATION AREA DIM B	OVERALL LENGTH DIM L	DIM H FOR .093/2.36 THK BOARD	DIM H FOR .125/3.18 THK BOARD
71258-010	.140/3.56	.100/2.54	.350/8.89	.318/8.08	.302/7.67
71258-020	.240/6.10	.040/1.02	.390/9.91	.148/3.76	.132/3.35
71258-030	.270/6.86	.040/1.02	.420/10.67	.248/6.30	.232/5.89
71258-040	.290/7.37	.040/1.02	.440/11.18	.278/7.06	.262/6.66
71258-050	.310/7.87	.040/1.02	.460/11.68	.298/7.57	.282/7.16
71258-060	.310/7.87	.090/2.29	.510/12.95	.318/8.08	.302/7.67
71258-070	.310/7.87	.120/3.05	.540/13.72	.318/8.08	.302/7.67
71258-080	.310/7.87	.170/4.32	.590/14.99	.318/8.08	.302/7.67
71258-090	.310/7.87	.270/6.86	.690/17.53	.318/8.08	.302/7.67
71258-100	.330/8.38	.040/1.02	.480/12.19	.338/8.59	.322/8.18
71258-110	.360/9.14	.040/1.02	.510/12.95	.368/9.35	.352/8.94
71258-120	.360/9.14	.310/7.87	.780/19.81	.368/9.35	.352/8.94
71258-130	.390/9.91	.040/1.02	.540/13.72	.398/10.11	.382/9.70
71258-140	.430/10.92	.040/1.02	.580/14.73	.438/11.25	.322/8.18
71258-150	.450/11.43	.040/1.02	.600/15.24	.458/11.63	.442/11.23
71258-160	.470/11.94	.460/11.68	1.040/26.42	.478/12.14	.462/11.74
71258-170	.485/12.32	.105/2.67	.700/17.78	.493/12.52	.477/12.12
71258-180	.567/14.40	.456/11.58	.933/23.70	.575/14.61	.559/14.20
71258-190	.585/14.86	.105/2.67	.800/20.32	.593/15.06	.577/14.60
71258-200	.590/14.99	.040/1.02	.740/18.80	.598/15.19	.582/14.78
71258-210	.705/17.91	.040/1.02	.855/21.72	.713/18.11	.697/17.70

NOTES:

- ① PIN MAT'L:  
3/4 HARD PHOS BRONZE  
PLATING:  
30μ" [0.76μ] MIN Au OVER 50μ" [1.27μ] MIN Ni.
- ② BURNISH MARKS ON PIN PERMITTED.  
BURR: .003 [0.08] MAX, BULGE: .0005 [0.013] MAX TYP.
3. SEE PRODUCT SPECIFICATION BUS-12-064 FOR P.C. BOARD HOLE DIAMETER AND P.C. BOARD HOLE PLATING INFORMATION.
- ④ FOR MANUFACTURING PURPOSES ONLY.
- ⑤ DOUBLE ENDED PINS AS MARKED MUST MEET SPECS IN VIEWS C AND D ON BOTH ENDS. OTHERS TO HAVE .016 [0.41] MAX DIM ON BOTTOM END OF PIN.
- ⑥ SOLDER MAY BULGE IN THIS AREA BUT WILL NOT TOUCH FERRULE.  
SOLDER VOLUME: 82.5 MIN PER PIN  
(.068 X .074 X .021 ) BEFORE FORMING.
7. "A" DIM. IS TO FEATURE ON PIN.  
"H" DIM. IS ABOVE BOARD.  
"B" DIM. IS TO FEATURE ON PIN.

mat'l. code SEE NOTE 1		surface ASME Y14.5		tolerance ASME Y14.5		projection 		product family PIN PRODUCTS	
ltr	ecn no	dr	date	tolerances unless otherwise specified				title BERGPIN® .200"[5.08]cc .041"[1.04] DIA., .110"[2.79] LONG STAR WITH SOLDER WASHER	
F				angles	XX*.01/XX*.3 XXX*.005/XXX*.13	INCH/MM		dwg no 71258	
				0"±2'	XXXX*.0020/XXX*.051	scale 1:1		sheet 3 of 3 size A4	
		dr	M. FETROW		1995-08-17			type CUSTOMER Drawing	
		enr	L. FYE		1995-08-17				
		chr	L. FYE		1995-08-17				
		appd	L. FYE		1995-08-17				
sheet index	revision sheet								