

REVISIONS			
REV	DESCRIPTION, ECN, EAR NO.	DATE	APP'D
A	PROPOSAL	OCT 08/14	L.CHAN

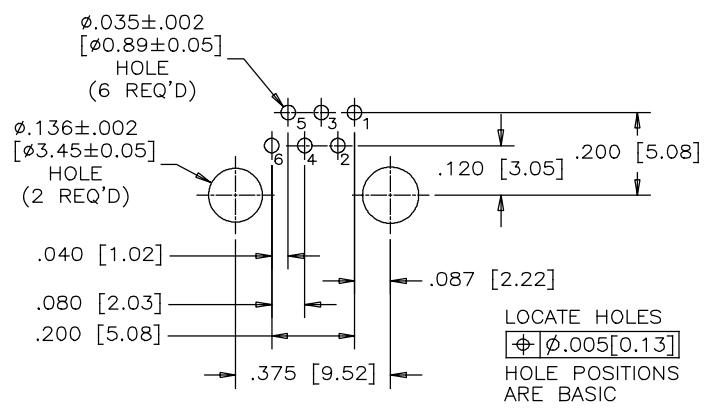

RECOMMENDED P.C.B. LAYOUT  
(COMPONENT SIDE OF BOARD)

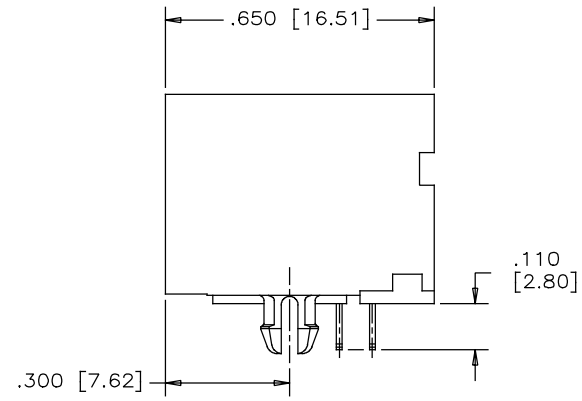
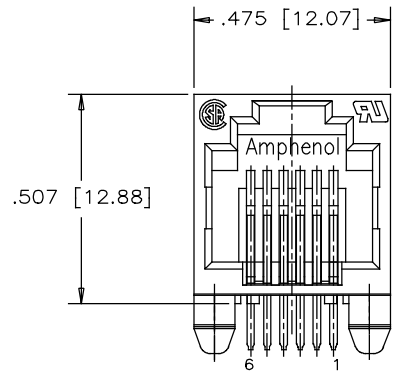
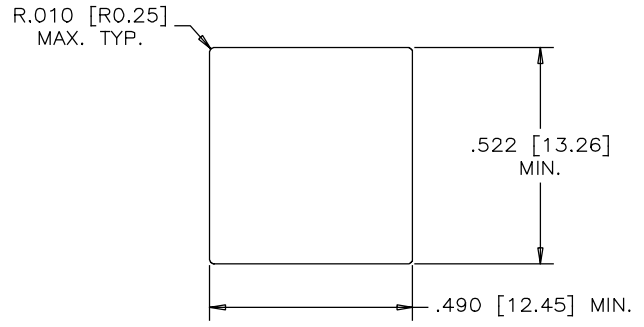

RECOMMENDED PANEL CUTOUT

**MATERIALS:**

PLASTIC HOUSING: HIGH TEMPERATURE RESISTANT NYLON  
UL FLAMMABILITY RATING 94V-0.  
COLOR: BLACK

CONTACTS: PHOSPHOR BRONZE

CONTACT PLATING: GOLD PLATED REFER TO PART NUMBER  
ON MATING SURFACES  
50 MICROINCHES [1.27 MICRONS] MIN NICKEL OVERALL  
100 MICROINCHES [2.54 MICRONS] MATTE-TIN  
ON CONTACT TAILS.

PART NUMBER: RJE01-X60-01

GOLD PLATING  
1 = 6 μ"  
6 = 50 μ"  
G = 15 μ"  
J = 30 μ"

THIS DOCUMENT CONTAINS PROPRIETARY INFORMATION AND SUCH INFORMATION MAY NOT BE DISCLOSED TO OTHERS FOR ANY PURPOSE OR USED FOR MANUFACTURING PURPOSES WITHOUT WRITTEN PERMISSION FROM AMPHENOL CANADA CORP.

UNLESS SPECIFIED OTHERWISE	DRAWN <i>Frank W</i>	DATE <i>oct 08/14</i>	Amphenol Canada Corp. www.amphenolcanada.com
PRIMARY UNITS INCH	CHECKED <i>Lawrence C</i>	DATE <i>oct 08/14</i>	
SECONDARY MILLIMETERS	M.E. APP'D		TITLE HIGH SPEED MODULAR JACK, 1 PORT, 6 POSITIONS, 6 CONTACTS, WITHOUT SHIELD -ROHS COMPLIANT
REFERENCE IN PARENTHESES	Q.A. APP'D		DWG. NO. P-RJE01-X60-01
GENERAL TOLERANCES	DWG APPR.		REV A
1 DECIMAL PLACE ±0.025	ENG. REL. NO.		CODE ID NO. 03554 DWG SIZE: C SCALE: N/A SHEET 1 OF 1
2 DECIMAL PLACES ±0.020	REF.		
3 DECIMAL PLACES ±0.015	THIRD ANGLE PROJECTION	DO NOT SCALE DRAWING	
ANGULAR DEGREES ±1.0°			