

Low Skew, Low Additive Jitter 3 x 5 LVPECL/LVDS/HCSL Fanout Buffer with one LVCMOS output

Features

- 3 to 1 input Multiplexer: Two inputs accept any differential (LVPECL, HCSL, LVDS, SSTL, CML, LVCMOS) or a single ended signal and the third input accepts a crystal or a single ended signal
- Five differential LVPECL/LVDS/HCSL outputs and one LVCMOS output
- Ultra-low additive jitter: 24fs (integration band 12kHz to 20MHz at 625MHz clock frequency)
- Supports clock frequencies from 0 to 1.6GHz
- Supports 2.5V or 3.3V power supplies for LVPECL, LVDS or HCSL outputs
- Supports 1.5V, 1.8V, 2.5V or 3.3V power supplies for LVCMOS output
- Embedded Low Drop Out (LDO) Voltage regulator provides superior Power Supply Noise Rejection
- Maximum output to output skew of 40ps
- Device controlled via SPI or hardware pins

Ordering Information

ZL40235LDG1	40 pin QFN	Trays
ZL40235LDF1	40 pin QFN	Tape and Reel
Package size: 6 x 6 mm		
-40°C to +85°C		

Applications

- General purpose clock distribution
- Low jitter clock trees
- Logic translation
- Clock and data signal restoration
- Wired communications: OTN, SONET/SDH, GE, 10 GE, FC and 10G FC
- PCI Express generation 1/2/3/4 clock distribution
- Wireless communications
- High performance microprocessor clock distribution
- Test Equipment

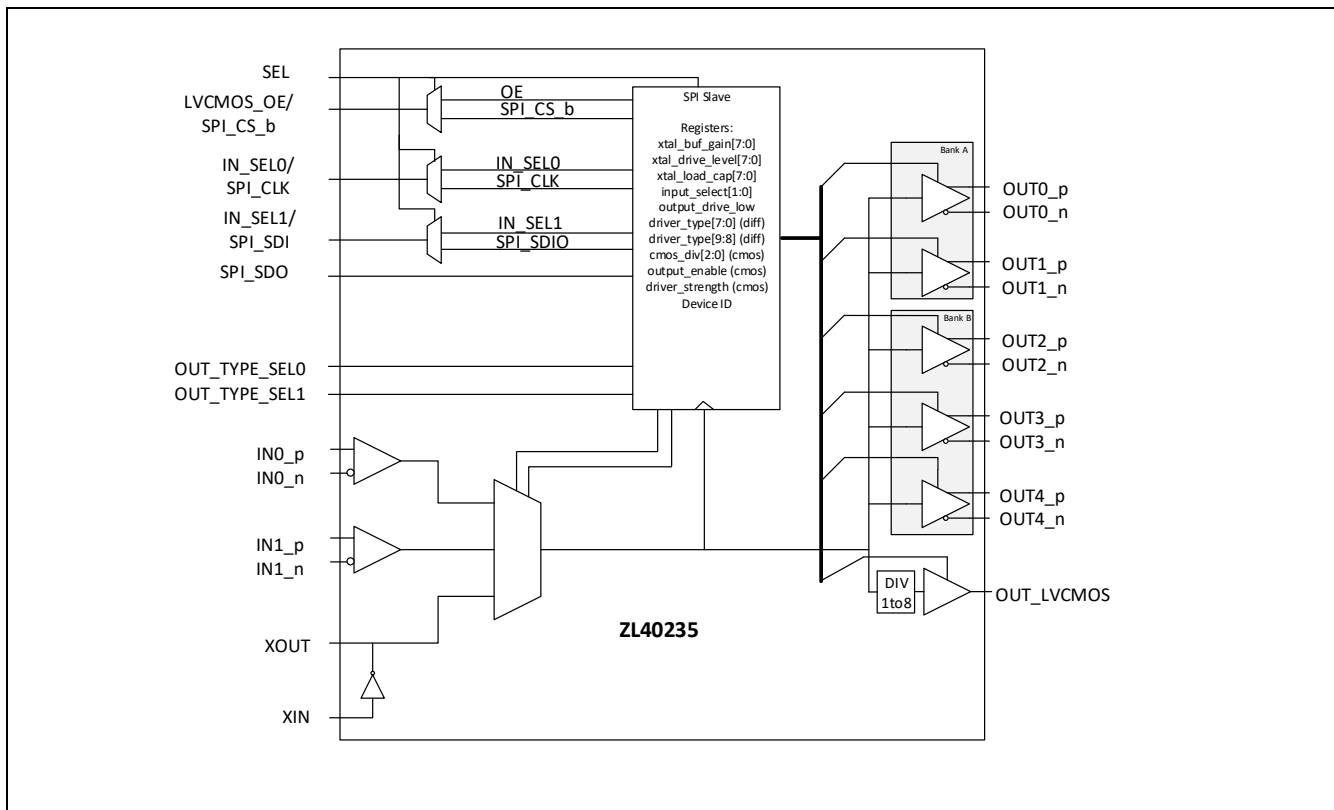

Figure 1. Functional Block Diagram

Table of Contents

Features	1
Applications.....	1
Table of Contents	2
Pin Diagram	5
Pin Descriptions	6
Functional Description	9
Clock Inputs	9
Clock Outputs	12
Crystal Oscillator Input.....	13
Termination of unused inputs and outputs	13
Power Consumption	13
Power Supply Filtering.....	14
Power Supplies and Power-up Sequence	14
Host Interface	14
Typical device performance.....	19
Register Map	23
AC and DC Electrical Characteristics	29
Absolute Maximum Ratings	29
Recommended Operating Conditions	29
Change History	48
Package Outline	49

List of Figures

Figure 1.	Functional Block Diagram.....	1
Figure 2.	Pin Diagram.....	5
Figure 3.	Input driven by a single ended output.....	9
Figure 4.	Input driven by DC coupled LVPECL output.....	9
Figure 5.	Input driven by DC coupled LVPECL output (alternative termination).....	10
Figure 6.	Input driven by AC coupled LVPECL output.....	10
Figure 7.	Input driven by HCSL output.....	10
Figure 8.	Input driven by LVDS output.....	11
Figure 9.	Input driven by AC coupled LVDS.....	11
Figure 10.	Input driven by an SSTL output.....	11
Figure 11.	Termination for LVCMOS outputs.....	12
Figure 12.	Driving a load via transformer.....	12
Figure 13.	Crystal Oscillator Circuit in Hardware Controlled Mode.....	13
Figure 14.	Power Supply Filtering.....	14
Figure 15.	SPI slave interface.....	16
Figure 16.	Serial Peripheral Interface Functional Waveform – LSB First Mode.....	17
Figure 17.	Serial Peripheral Interface Functional Waveform – MSB First Mode.....	17
Figure 18.	Example of the Burst Mode Operation.....	18
Figure 19.	156.25MHz LVPECL.....	19
Figure 20.	1.5GHz LVPECL.....	19
Figure 21.	156.25MHz LVDS.....	19
Figure 22.	1.5GHz LVDS.....	19
Figure 23.	100MHz HCSL.....	19
Figure 24.	250MHz HCSL.....	19
Figure 25.	I/O delay vs temperature.....	20
Figure 26.	PSNR vs noise frequency.....	20
Figure 27.	100MHz LVPECL Phase Noise.....	20
Figure 28.	100MHz LVDS Phase Noise.....	20
Figure 29.	156.25MHz LVDS Phase Noise in Xtal mode.....	20
Figure 30.	100MHz HCSL Phase Noise.....	20
Figure 31.	156.25MHz LVPECL Phase Noise.....	21
Figure 32.	625MHz LVPECL Phase Noise.....	21
Figure 33.	156.25MHz LVDS Phase Noise.....	21
Figure 34.	625MHz LVDS Phase Noise.....	21
Figure 35.	Output RMS jitter (12kHz to 20MHz) vs input clock slew-rate.....	22
Figure 36.	Output clock noise floor vs input clock slew-rate.....	22
Figure 37.	Output RMS jitter (12kHz to 20MHz) vs input clock slew-rate.....	22
Figure 38.	Output clock noise floor vs input clock slew-rate.....	22
Figure 39.	Output RMS jitter (12kHz to 20MHz) vs input clock slew-rate.....	22
Figure 40.	Output clock noise floor vs input clock slew-rate.....	22
Figure 41.	Differential Input Voltage Levels.....	30
Figure 42.	Differential Output Voltage Levels.....	34
Figure 43.	SPI (Serial Peripheral Interface) Timing - LSB First Mode.....	46
Figure 44.	SPI (Serial Peripheral Interface) Timing - MSB First Mode.....	46

List of Tables

Table 1 Pin Description.....	6
Table 2 Input clock selection	15
Table 3 Output Type Selection.....	15
Table 4 Register Map	23
Table 5 Absolute Maximum Ratings*.....	29
Table 6 Recommended Operating Conditions*	29
Table 7 Current consumption	29
Table 8 Input Characteristics*.....	30
Table 9 Crystal Oscillator Characteristics*	31
Table 10 Power Supply Rejection Ratio for $VDD = VDDO = 3.3V^*$	31
Table 11 Power Supply Rejection Ratio for $VDD = VDDO = 2.5V^*$	32
Table 12 LVCMOS Output Characteristics for $VDDO = 3.3V^*$	32
Table 13 LVCMOS Output Characteristics for $VDDO = 2.5V^*$	33
Table 14 LVPECL Output Characteristics for $VDDO = 3.3V^*$	34
Table 15 LVPECL Output Characteristics for $VDDO = 2.5V^*$	35
Table 16 LVDS Outputs for $VDDO = 3.3V^*$	36
Table 17 LVDS Outputs for $VDDO = 2.5V^*$	37
Table 18 HCSL Outputs for $VDDO = 3.3V^*$	38
Table 19 HCSL Outputs for $VDDO = 2.5V^*$	39
Table 20 LVCMOS Output Phase Noise with 25 MHz XTAL*	40
Table 21 LVPECL Output Phase Noise with 25 MHz XTAL*	40
Table 22 LVDS Output Phase Noise with 25 MHz XTAL	41
Table 23 HCSL Output Phase Noise with 25 MHz XTAL	41
Table 24 LVCMOS Output Phase Noise with 125 MHz XTAL*	42
Table 25 LVPECL Output Phase Noise with 125 MHz XTAL*	42
Table 26 LVDS Output Phase Noise with 125 MHz XTAL	43
Table 27 HCSL Output Phase Noise with 125 MHz XTAL	43
Table 28 LVCMOS Output Phase Noise with 156.25 MHz XTAL*	44
Table 29 LVPECL Output Phase Noise with 156.25 MHz XTAL*	44
Table 30 LVDS Output Phase Noise with 156.25 MHz XTAL	45
Table 31 HCSL Output Phase Noise with 156.25 MHz XTAL	45
Table 32 AC Electrical Characteristics* - SPI (Serial Peripheral Interface) Timing	46
Table 33 6x6mm QFN Package Thermal Properties	47

Pin Diagram

The device is packaged in a 6 x 6 mm 40-pin QFN.

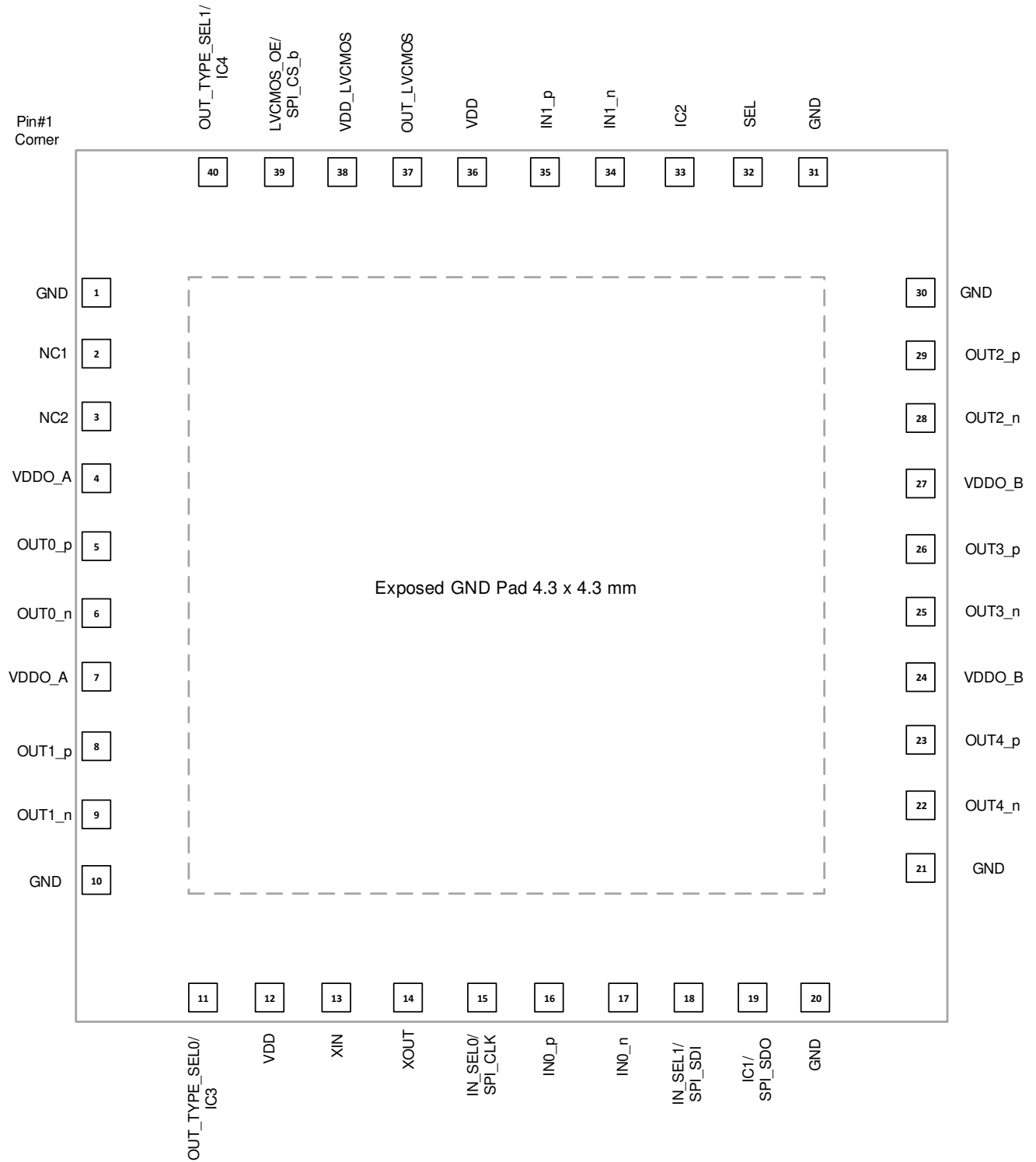

Figure 2. Pin Diagram

Pin Descriptions

All device inputs and outputs are LVPECL unless described otherwise. The I/O column uses the following symbols: I – input, I_{PU} – input with 300kΩ internal pull-up resistor, I_{PD} – input with 300kΩ internal pull-down resistor, I_{APU} – input with 31kΩ internal pull-up resistor, I_{APD} – input with 30kΩ internal pull-down resistor, I_{APU/APD} – input with 60kΩ internal pull-up and pull-down resistors (30 kΩ equivalent), O – output, I/O – Input/Output pin, NC – No connect, P – power supply pin.

Table 1 Pin Description

#	Name	I/O	Description
Input Reference			
16 17 35 34	IN0_p IN0_n IN1_p IN1_n	I _{APD} I _{APU/APD} I _{APD} I _{APU/APD}	<p>Input Differential or Single Ended References 0 and 1</p> <p>Input frequency range 0Hz to 1.6GHz.</p> <p>Non- inverting inputs (_p) are pulled down with internal 30kΩ pull-down resistors. Inverting inputs (_n) are biased at VDD/2 with 60kΩ pull-up and pull-down resistors to keep inverting input voltages at VDD/2 when inverting inputs are left floating (device fed with a single ended reference).</p>
Output Clocks			
5 6 8 9 29 28 26 25 23 22	OUT0_p OUT0_n OUT1_p OUT1_n OUT2_p OUT2_n OUT3_p OUT3_n OUT4_p OUT4_n	O	<p>Ultra-Low Additive Jitter Differential LVPECL/HCSL/LVDS Outputs 0 to 4</p> <p>Output frequency range 0 to 1.6GHz</p> <p>In SPI bus controlled mode (SEL pin pulled high on the power up) type (LVPECL/HCSL/LVDS/High-Z) of each output is programmable via SPI bus</p> <p>In Hardware control mode (SEL pin pulled low on the power up) type (LVPECL/HCSL/LVDS/High-Z) of each output bank is controlled via OUTA/B_TYPE_SEL0/1 pins</p>
37	OUT_LVCMOS	O	<p>Ultra-Low Additive Jitter LVCMOS Output</p> <p>Output frequency range 0 to 250MHz</p>
Control			
32	SEL	I _{PD}	<p>Select control.</p> <p>When this pin is low, the device is controlled via hardware pins, IN_SEL0/1 and OE. When this pin is high, the device is controlled via SPI port.</p> <p>Any change of SEL pin value requires power cycle. Hence, SEL pin cannot be changed on the fly.</p>

15	IN_SEL0/SPI_CLK	I_{PD} or I_{PU}	<p>Input Select 0 or Clock for Serial Interface. When SEL pin is low this pin is Input Select 0 hardware control input pin and it is pulled-down with 300 kΩ resistor. When SEL pin is high this pin provides clock for serial micro-port interface and it is pulled-up with 300 kΩ resistor.</p> <table border="1" data-bbox="618 331 1511 562"> <thead> <tr> <th>IN_SEL1</th> <th>IN_SEL0</th> <th>OUTN</th> </tr> </thead> <tbody> <tr> <td>0</td> <td>0</td> <td>Input 0 (IN0)</td> </tr> <tr> <td>0</td> <td>1</td> <td>Input 1 (IN1)</td> </tr> <tr> <td>1</td> <td>0</td> <td>Crystal Oscillator or overdrive</td> </tr> <tr> <td>1</td> <td>1</td> <td>Crystal Bypass</td> </tr> </tbody> </table>	IN_SEL1	IN_SEL0	OUTN	0	0	Input 0 (IN0)	0	1	Input 1 (IN1)	1	0	Crystal Oscillator or overdrive	1	1	Crystal Bypass
IN_SEL1	IN_SEL0	OUTN																
0	0	Input 0 (IN0)																
0	1	Input 1 (IN1)																
1	0	Crystal Oscillator or overdrive																
1	1	Crystal Bypass																
18	IN_SEL1/SPI_SDI	I_{PD} or I_{PU}	<p>Input Select 1 or Serial Interface Input. When SEL pin is low this pin is Input Select 1 hardware control pin and it is pulled-down with 300 kΩ resistor. When SEL pin is high this pin is serial interface input stream and it is pulled-up with 300 kΩ resistor. The serial data stream holds the access command, the address and the write data bits.</p>															
19	IC1/SPI_SDO	I/O	<p>Internal Connection 1 or Serial Interface Output. When SEL pin is low this pin in an internal connection. Leave open. When SEL pin is high this pin is Serial interface output stream. As an output the serial stream holds the read data bits.</p>															
33	IC2	I_{PD}	<p>Internal Connection 2. This pin should be left open.</p>															
39	LVCMOS_OE/ SPI_CS_b	I_{PD} or I_{PU}	<p>LVCMOS Output Enable or Chip Select for Serial Interface. When SEL pin is low this pin is LVCMOS Output Enable hardware control input and it is pulled-down with 300 kΩ resistor. When SEL pin is high this pin is serial interface chip select and it is pulled-up with 300 kΩ resistor--this is an active low signal.</p>															
11 40	OUT_TYPE_SEL0/ IC3 OUT_TYPE_SEL1/ IC4	I_{PD}	<p>Output Signal Type: When SEL pin is low these two pins Selects Type for all outputs</p> <table border="1" data-bbox="618 1591 1511 1822"> <thead> <tr> <th>OUT_TYPE_SEL1</th> <th>OUT_TYPE_SEL0</th> <th>Output 0 to 4</th> </tr> </thead> <tbody> <tr> <td>0</td> <td>0</td> <td>LVPECL</td> </tr> <tr> <td>0</td> <td>1</td> <td>LVDS</td> </tr> <tr> <td>1</td> <td>0</td> <td>HCSL</td> </tr> <tr> <td>1</td> <td>1</td> <td>High-Z (Disabled)</td> </tr> </tbody> </table> <p>When SEL pin is high these two pins are unused and should be left unconnected.</p>	OUT_TYPE_SEL1	OUT_TYPE_SEL0	Output 0 to 4	0	0	LVPECL	0	1	LVDS	1	0	HCSL	1	1	High-Z (Disabled)
OUT_TYPE_SEL1	OUT_TYPE_SEL0	Output 0 to 4																
0	0	LVPECL																
0	1	LVDS																
1	0	HCSL																
1	1	High-Z (Disabled)																

Crystal Oscillator			
13	XIN	I	Crystal Oscillator Input or crystal bypass mode or crystal overdrive mode If crystal oscillator is not used pull down this pin or connect it to ground.
14	XOUT	O	Crystal Oscillator Output
No Connect			
2 3	NC1 NC2	NC	No Connect (not connected to the die) Leave unconnected or connect to GND for mechanical support
Power and Ground			
12 36	VDD	P	Positive Supply Voltage. Connect to 3.3V or 2.5V supply.
4 7	VDDO_A	P	Positive Supply Voltage for Differential Outputs Bank A Connect 3.3V or 2.5V power supply. VDDO_A does not have to be connected to the same voltage level as VDD or VDDO_B. These pins power up differential outputs OUT0_p/n and OUT1_p/n.
24 27	VDDO_B	P	Positive Supply Voltage for Differential Outputs Bank B Connect 3.3V or 2.5V power supply. VDDO_B does not have to be connected to the same voltage level as VDD or VDDO_A. These pins power up differential outputs OUT2_p/n, OUT3_p/n and OUT4_p/n.
38	VDD_LVCMOS	P	Positive Supply Voltage for LVCMOS Output Connect 3.3V, 2.5V, 1.8V or 1.5V power supply
1 10 20 21 30 31	GND	P	Ground Connect to ground
E-Pad	GND	P	Ground. Connect to ground

Functional Description

The ZL40235 is a programmable or hardware pin controlled low additive jitter, low power 3 x 5 LVPECL/HCSL/LVDS fanout buffer.

Two inputs can accept signal in differential (LVPECL, SSTL, LVDS, HSTL, CML) or single ended (LVPECL or LVCMOS) format and the third input can accept a single ended signal or it can be used to build a crystal oscillator by connecting an external crystal resonator between its XIN and XOUT pins. All the other components for building crystal oscillator are built in device such as load capacitance, series and shunt resistors.

The ZL40235 has five LVPECL/HCSL/LVDS outputs which can be powered from 3.3V or 2.5V supply. Each output can be independently enabled/disabled via SPI bus. The type of each output driver can be programmed to be LVPECL, HCSL or LVDS. Hence, the device can be configured to support application where different signal formats are needed.

The device operates from 2.5V+/-5% or 3.3V+/-5% supply. Its operation is guaranteed over the industrial temperature range -40°C to +85°C.

Clock Inputs

The following blocks diagram shows how to terminate different signals fed to the ZL40235 inputs.

Figure 3 shows how to terminate a single ended output such as LVCMOS. Ideally, resistors R1 and R2 should be 100Ω each and $R_o + R_s$ should be 50Ω so that the transmission line is terminated at both ends with characteristic impedance. If the driving strength of the output driver is not sufficient to drive low impedance, the value of series resistor R_s should be increased. This will reduce the voltage swing at the input but this should be fine as long as the input voltage swing requirement is not violated (Table 8). The source resistors of $R_s = 270\Omega$ could be used for standard LVCMOS driver. This will provide 516mV of voltage swing for 3.3V LVCMOS driver with load current of $(3.3V/2) * (1/(270\Omega + 50\Omega)) = 5.16mA$.

For optimum performance both differential input pins ($_p$ and $_n$) need to be DC biased to the same voltage. Hence, the ratio $R1/R2$ should be equal to the ratio $R3/R4$.

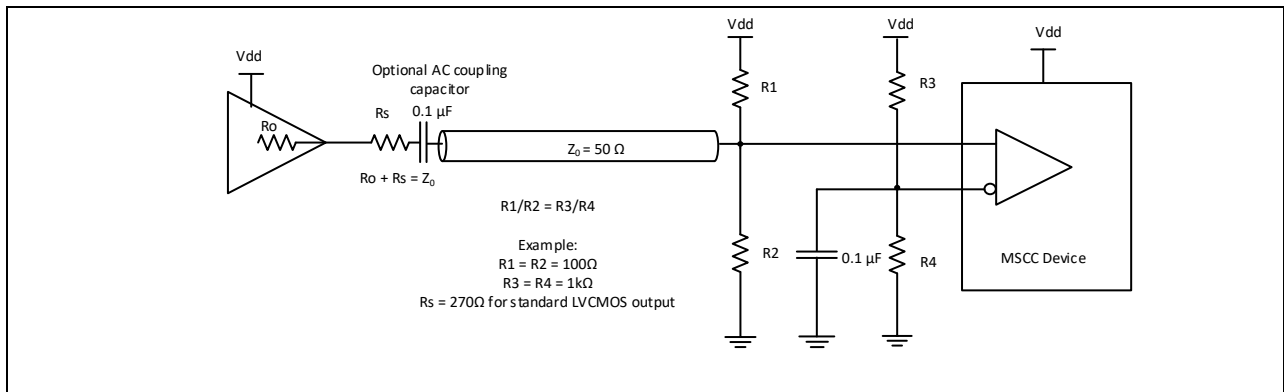

Figure 3. Input driven by a single ended output

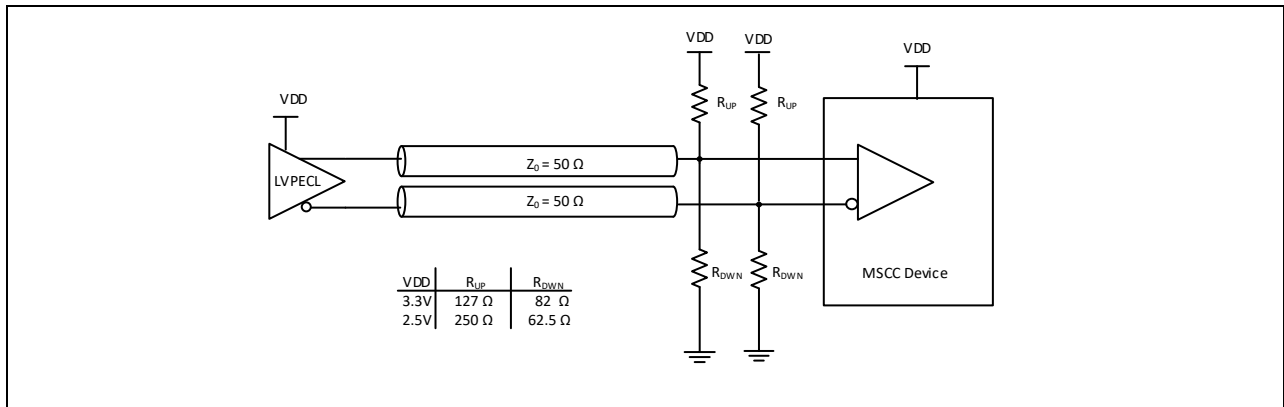

Figure 4. Input driven by DC coupled LVPECL output

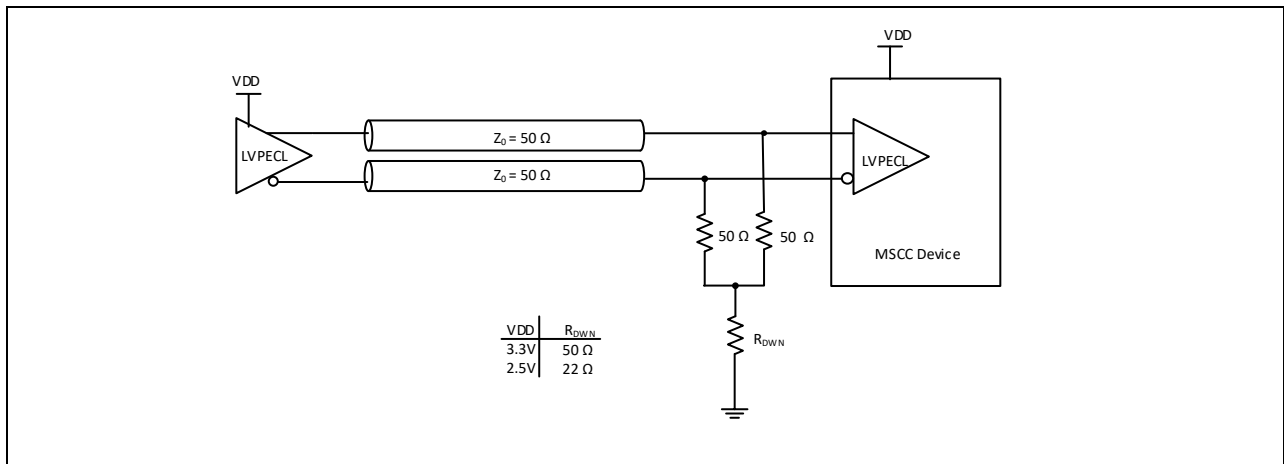

Figure 5. Input driven by DC coupled LVPECL output (alternative termination)

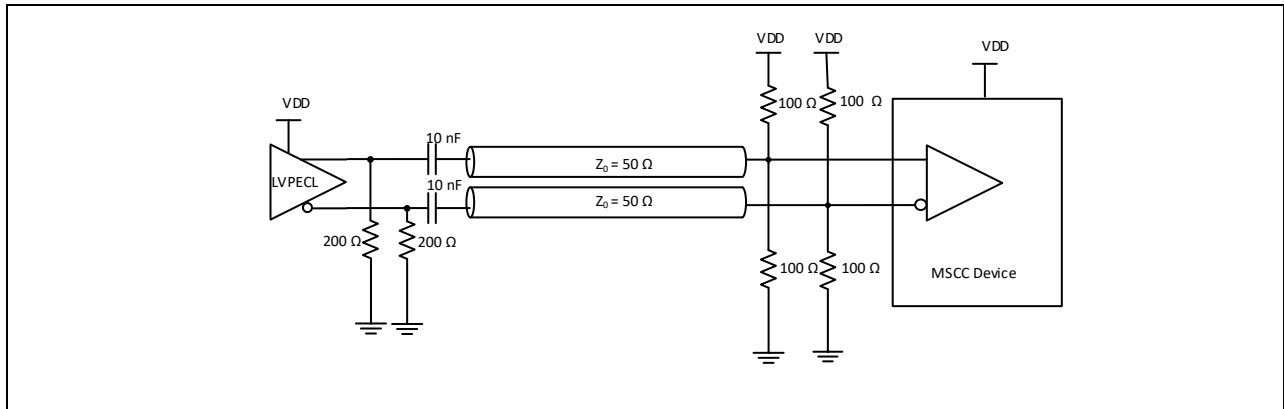

Figure 6. Input driven by AC coupled LVPECL output

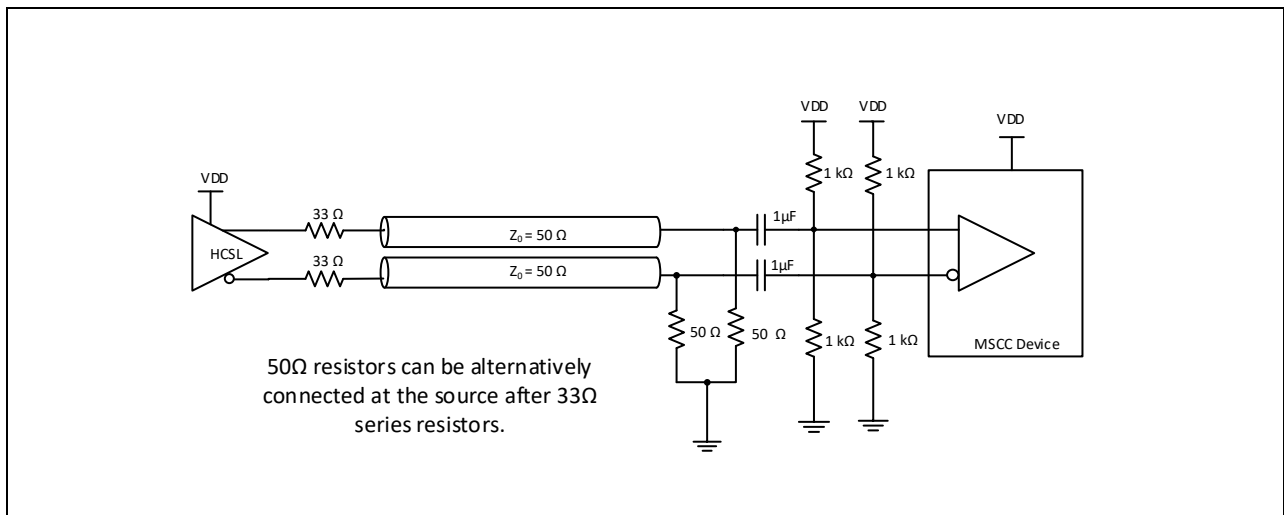

Figure 7. Input driven by HCSL output

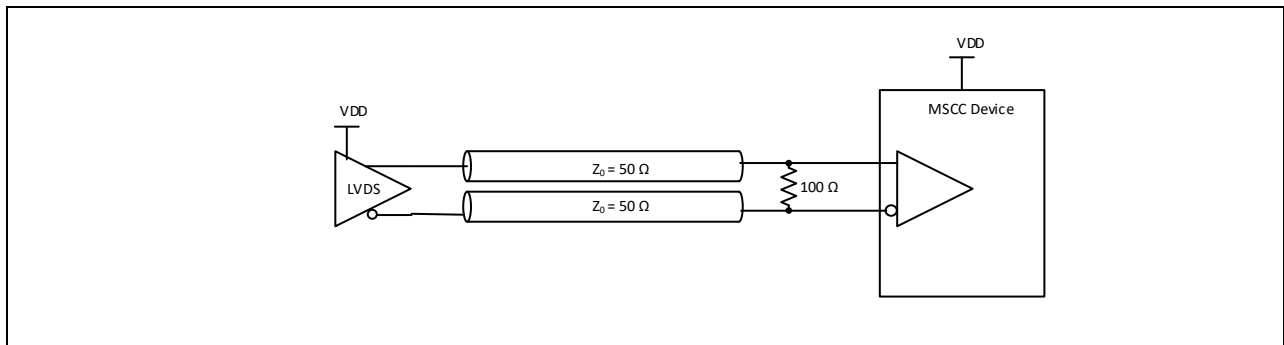

Figure 8. Input driven by LVDS output

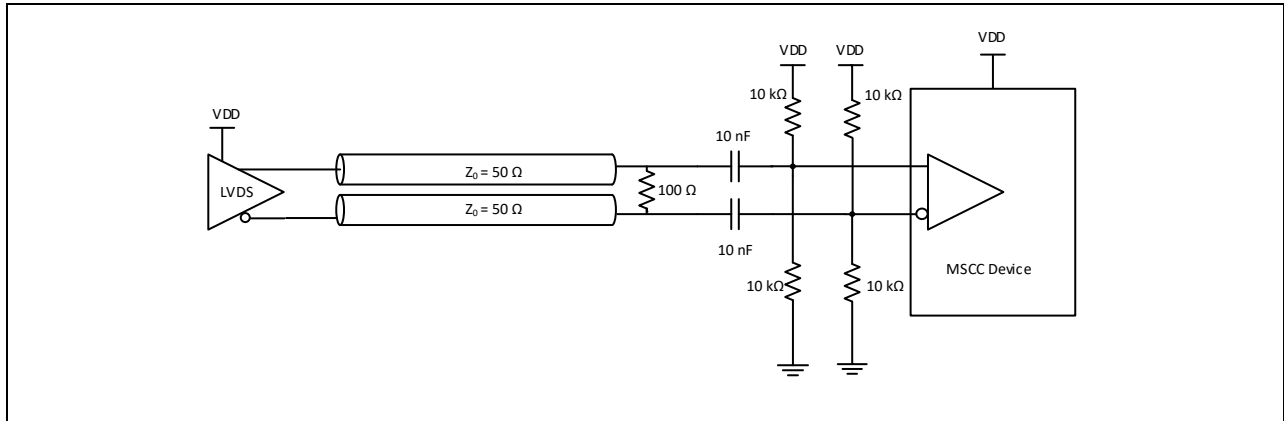

Figure 9. Input driven by AC coupled LVDS

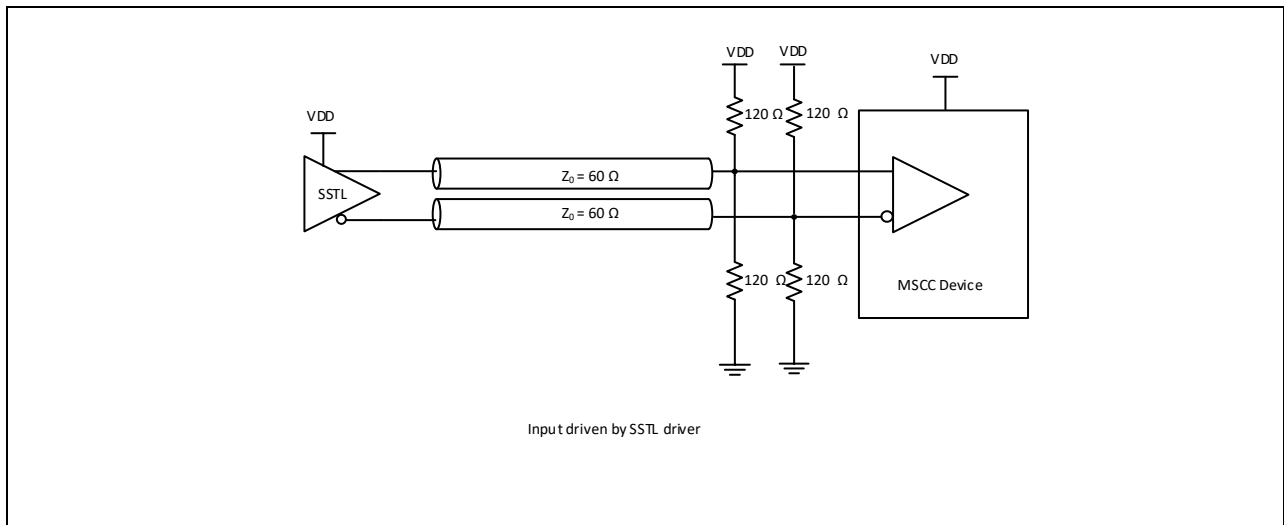

Figure 10. Input driven by an SSTL output

Clock Outputs

LVC MOS output OUT10 require only series termination resistor whose value is depending on LVC MOS output voltage as shown in Figure 11.

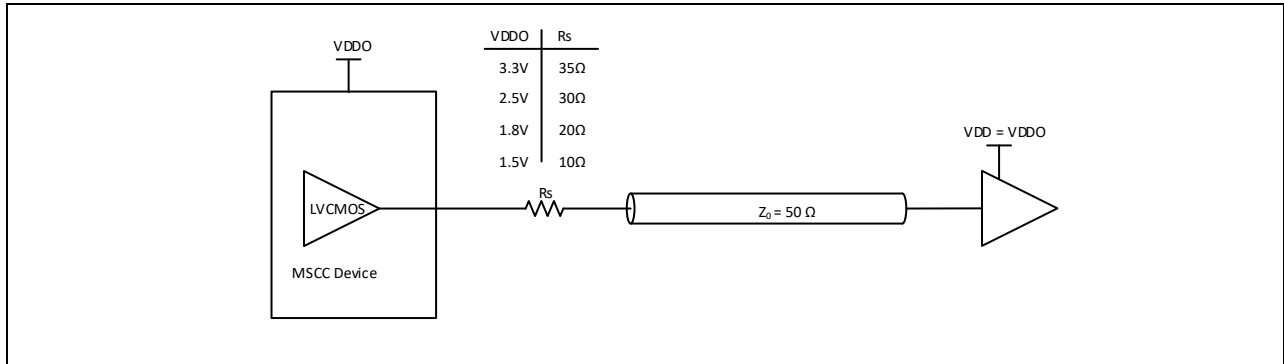

Figure 11. Termination for LVC MOS outputs

Differential outputs LVPECL and LVDS should have same termination as corresponding outputs described in previous section. HCSL outputs should be terminated with 33Ω series resistors at the source and 50Ω shunt resistors at the source or at the end on the transmission line. AC coupling and re-biasing is not required at the outputs when driving native HCSL receivers.

The device is designed to drive differential input of semiconductor devices. In applications that use a transformer to convert from the differential to the single ended output (for example driving an oscilloscope 50Ω input), a resistor larger than 10Ω should be added at the center tap of the primary winding to achieve optimum jitter performance as shown in Figure 12. This is to provide a nominal common mode impedance of 10Ω or higher which is typical for differential terminations.

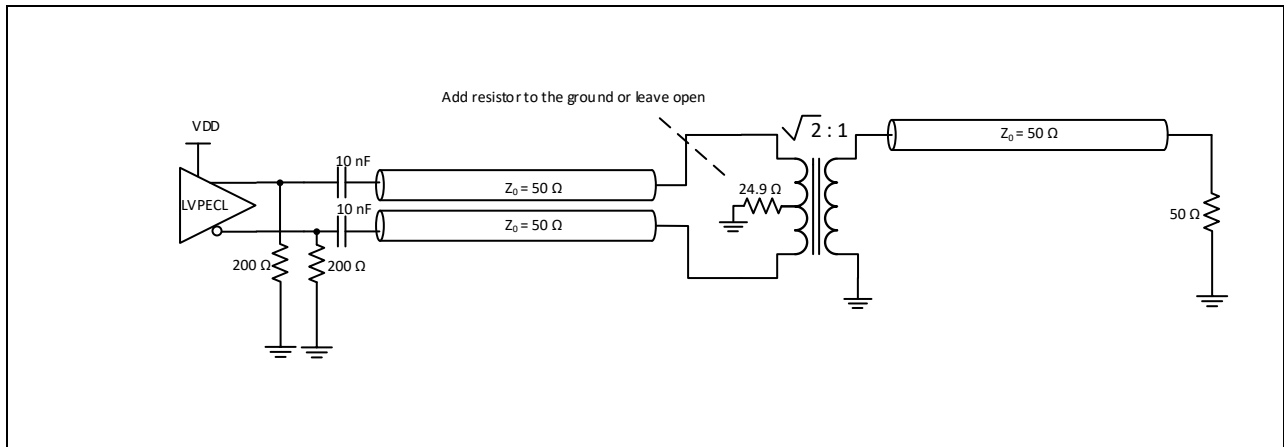

Figure 12. Driving a load via transformer

Crystal Oscillator Input

The crystal oscillator circuit can work with crystal resonators from 8MHz to 160MHz. To be able support crystal resonators with different characteristics all internal components are programmable.

The load capacitors can be programmed from 0 to 21.75 pF (4pF default) with resolution of 0.25pF which not only meets load requirement for most crystal resonator but also allows for fine tuning of the crystal resonator frequency. The amplifier gain can be adjusted in five steps and series resistor can be adjusted as parallel combination of seven different resistors: 0Ω, 10.5Ω, 21Ω, 42Ω, 84Ω, 161Ω and 312Ω (84Ω default). Although the first resistor is 0Ω the series resistance R_s will be slightly higher than 0Ω due to parasitic resistance of the switch which connects resistor. Hence the minimum series resistance is achieved when all seven resistors are connected in parallel. The shunt resistor is fixed and its value is 500kΩ.

In Hardware Controlled mode the capacitive load is set at 4pF, internal series resistance to 84Ω and they cannot be changed. For Crystal requiring higher load or series resistance additional capacitance and/or series resistance can be added externally as shown in the Figure 13.

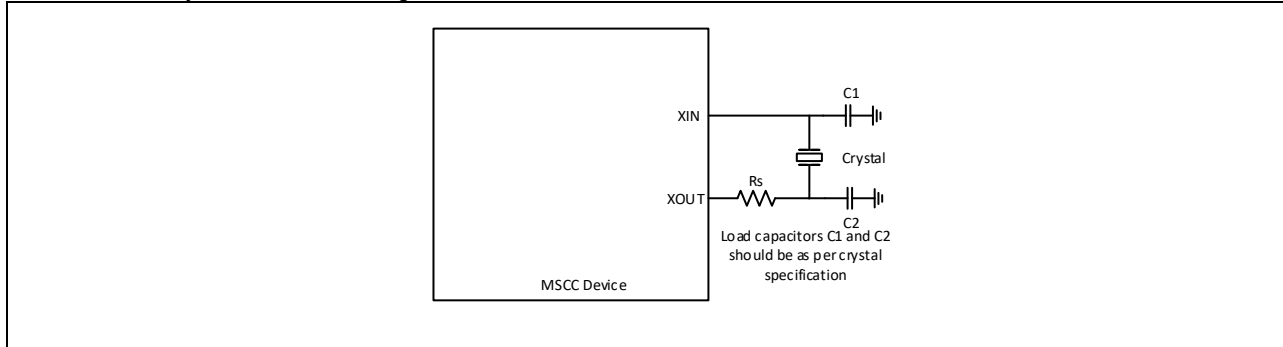

Figure 13. Crystal Oscillator Circuit in Hardware Controlled Mode

Termination of unused inputs and outputs

Unused inputs can be left unconnected or alternatively IN_0/1 can be pulled-down by 1kΩ resistor. Unused outputs should be left unconnected.

Power Consumption

The device total power consumption can be calculated as:

$$P_T = P_S + P_{XTAL} + P_C + P_{O_DIF} + P_{O_LVCMOS}$$

Where:

$$P_S = V_{DD} \times I_S$$

The core power when XTAL is not used. The current is specified in Table 7. If XTAL is running this power should be set to zero.

$$P_{XTAL} = V_{DD} \times I_{DD_XTAL}$$

The core power when XTAL is used. The current is provided in Table 7. If XTAL is not used this power should be set to zero.

$$P_C = V_{DDO} \times I_{DD_CM}$$

Common output power shared among all ten outputs. The current I_{DD_CM} is specified in Table 7.

$$P_{O_DIF} = V_{DDO} \times (I_{DD_LVDS} \times N_1 + I_{DD_LVPECL} \times N_2 + I_{DD_HCSL} \times N_3)$$

Output power where output currents are specified in Table 7.

N_1 , N_2 and N_3 are number of enabled LVPECL, LVDS and HSCL outputs respectively and $N_1+N_2+N_3$ is less or equal to 5.

$$P_{O_LVCMOS} = V_{DD_LVCMOS} \times (I_{DD} \times f / 100MHz + V_{DD_LVCMOS} \times C_{LOAD} \times f)$$

Dynamic LVCMOS output power. I_{DD} is specified in Table 7. If LVCMOS output is disabled this term is equal to zero.

Power dissipated inside the device can be calculated by subtracting power dissipated in termination/biasing resistors from the power consumption.

$$P_D = P_T - N_1 \times P_{LVPECL} - N_2 \times P_{LVDS} - N_3 \times P_{HCSL}$$

Where N_1 , N_2 and N_3 are number of enabled LVPECL, LVDS and HSCL outputs respectively. Since there are five differential outputs $N_1 + N_2 + N_3$ is less or equal to 5.

$$P_{LVPECL} = (V_{OH} - V_B)^2 / 50\Omega + (V_{OL} - V_B)^2 / 50\Omega + (V_{OH} - V_B) \times V_B / 50\Omega + (V_{OL} - V_B) \times V_B / 50\Omega$$

V_{OH} and V_{OL} are the output high and low voltages respectively for LVPECL output

V_B is LVPECL bias voltage equal to $V_{DD} - 2V$

$$P_{LVDS} = V_{SW}^2 / 100\Omega$$

V_{SW} is voltage swing of LVDS output.

$$P_{HCSL} = (V_{SW} / 50\Omega)^2 \times (33\Omega + 50\Omega)$$

V_{SW} is voltage swing of HCSL output. 50Ω is termination resistance and 33Ω is series resistance of the HCSL output.

Power Supply Filtering

Each power pin (VDD and VDDO) should be decoupled with $0.1\mu F$ capacitor with minimum equivalent series resistance (ESR) and minimum series inductance (ESL). For example, 0402 X5R Ceramic Capacitors with 6.3V minimum rating could be used. These capacitors should be placed as close as possible to the power pins. To reduce the power noise from adjacent digital components on the board each power supply could be further insulated with low resistance ferrite bead with two capacitors. The ferrite bead will also insulate adjacent component from the noise generated from the device. Following figure shows recommended decoupling for each power pin.

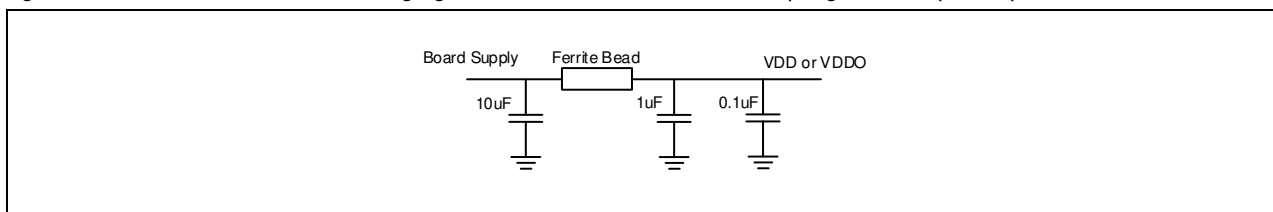

Figure 14. Power Supply Filtering

Power Supplies and Power-up Sequence

The device has four different power supplies: VDD, VDDO_A, VDDO_B and VDD_LVCMOS which are mutually independent. Voltages supported by each of these power supplies are specified in Table 1.

The device is not sensitive to the power-up sequence. For example, commonly used sequence where higher voltage comes up before or at the same time as the lower voltages can be used (or any other sequence)

Host Interface

ZL30235 can be controlled via hardware pins (SEL pin tied low) or via SPI port (SEL pin tied high). The mode shall be selected during power up and it cannot be changed on the fly.

Hardware Control Mode

In this mode, ZL40235 is controlled via Input Select (IN_SEL0/1) pins which select which one of three inputs is fed to the output and show in Table 2 and OUT_TYPE_SEL0/1 pins which select signal level (LVPECL, LVDS, HCSL or Hi-Z) as shown in Table 3.

All input control pins have low input threshold voltage so they can be driven from the device with low output voltage (FPGA/CPLD). Supported voltages are between 1.2V and VDD (2.5V or 3.3V).

Table 2 Input clock selection

IN_SEL1	IN_SEL0	Selected Input
0	0	IN0_p, IN0_n
0	1	IN1_p, IN1_n
1	X	XIN

Table 3 Output Type Selection

OUT_TYPE_SEL1	OUT_TYPE_SEL0	Output
0	0	LVPECL
0	1	LVDS
1	0	HCSL
1	1	High-Z (Output Disabled)

SPI Control Mode

ZL40235 is controlled via four pin SPI slave interface as shown in the following figure.

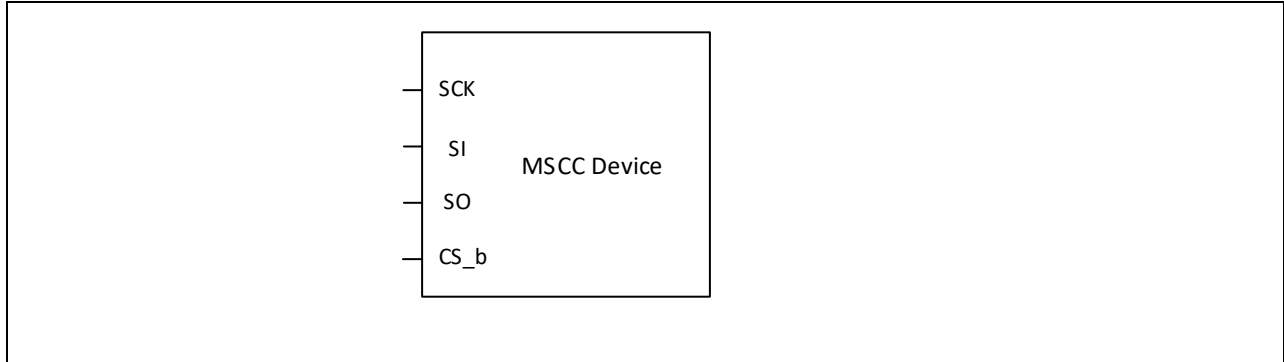

Figure 15. SPI slave interface

All SPI input pins have low threshold voltage so they can be driven from low output voltage SPI master device. Supported voltages are between 1.2V and VDD (2.5V or 3.3V). This allows device to be controlled from an FPGA with low voltage I/O supply.

The serial peripheral interface supports half-duplex processor mode which means that during a write cycle to the device, output data from the **SO** pin must be ignored. Similarly, the input data on the **SI** pin is ignored by the device during a read cycle.

The SPI interface supports two modes of access: Most Significant bit (MSb) first transmission or Least Significant bit (LSb) first transmission. The mode is automatically selected based on the state of **SCK** pin when the **CS_b** pin is active. If the **SCK** pin is low during **CS_b** activation, then MSb first timing is selected. If the **SCK** pin is high during **CS_b** activation, then LSb first timing is assumed.

The SPI port expects 1-bit to differentiate between read and write operation followed by 7-bit addressing and 8-bit data transmission. During SPI access, the **CS_b** pin must be held low until the operation is complete. Burst read/write mode is also supported by leaving the chip select signal **CS_b** is low after a read or a write. The address will be automatically incremented after each data byte is read or written.

Functional waveforms for the LSb and MSb first mode, and burst mode are shown in Figure 16 and Figure 17 respectively. Figure 18 shows an example of burst mode operation which allows user to read or write consecutive location in the register map.

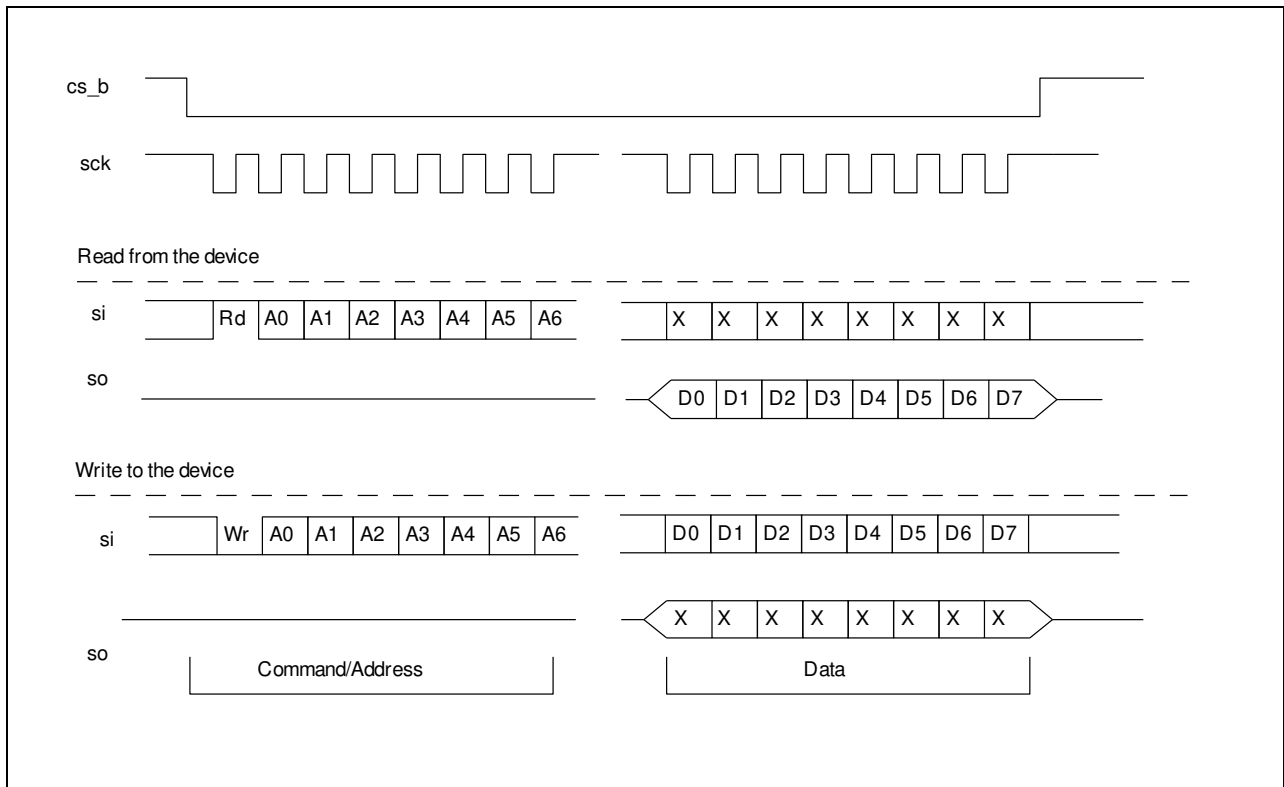

Figure 16. Serial Peripheral Interface Functional Waveform – LSB First Mode

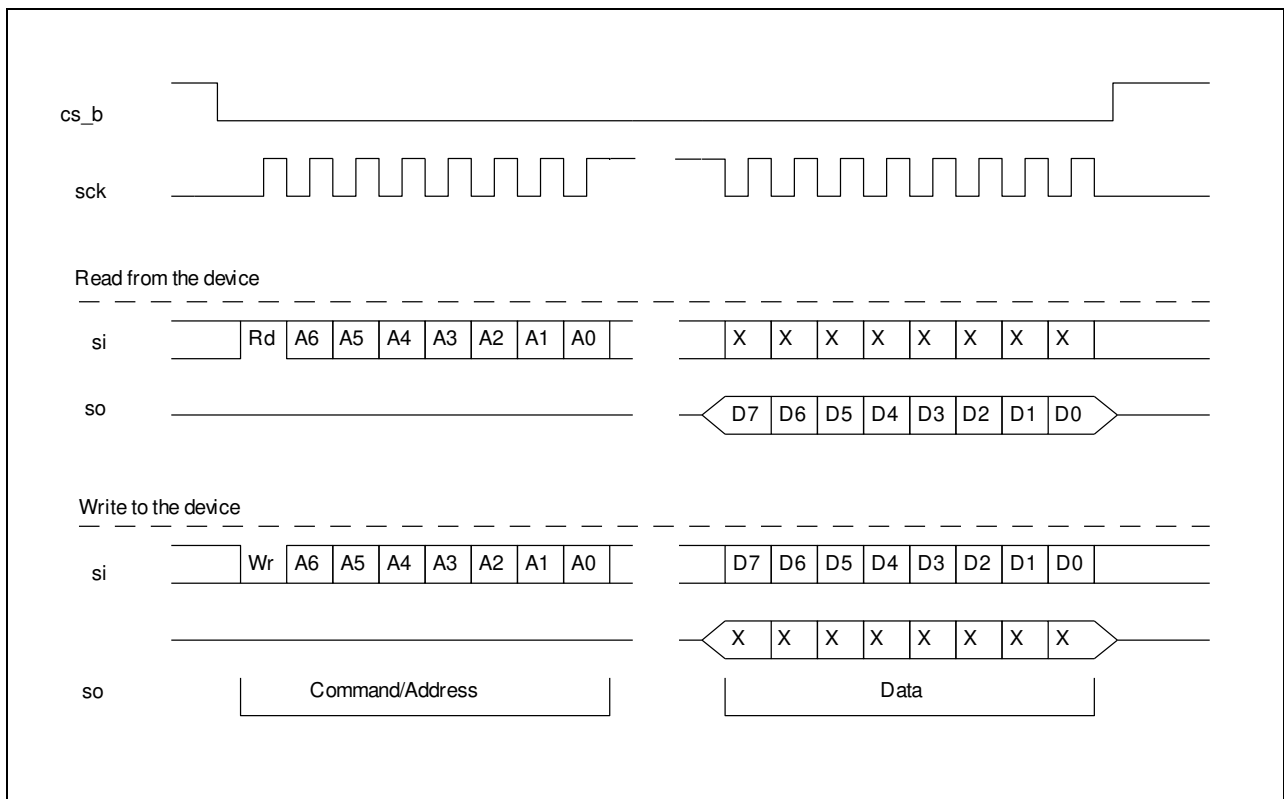

Figure 17. Serial Peripheral Interface Functional Waveform – MSB First Mode

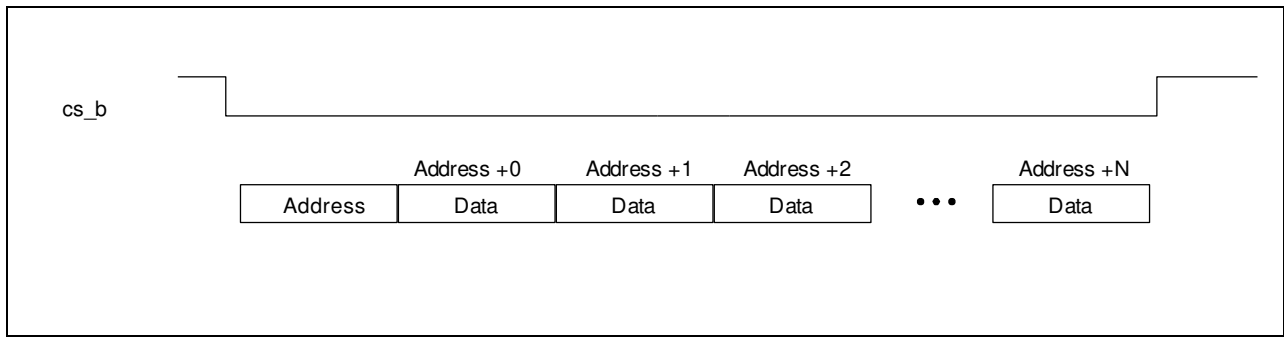

Figure 18. Example of the Burst Mode Operation

Typical device performance

The following plots show typical device performances

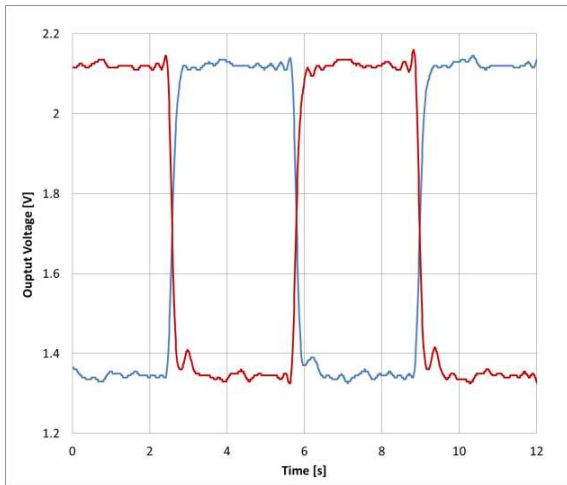

Figure 19. 156.25MHz LVPECL

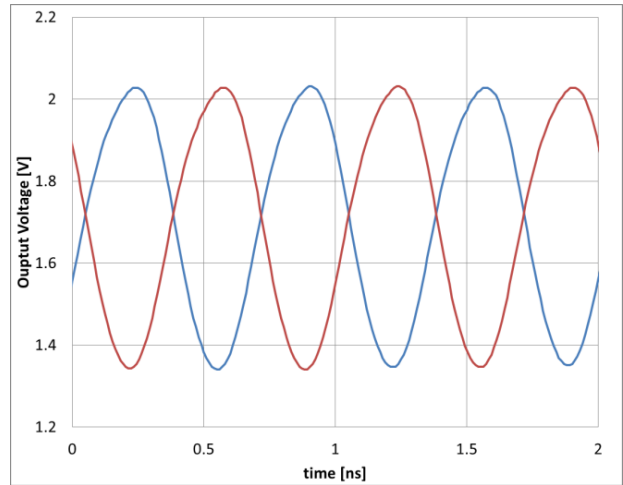

Figure 20. 1.5GHz LVPECL

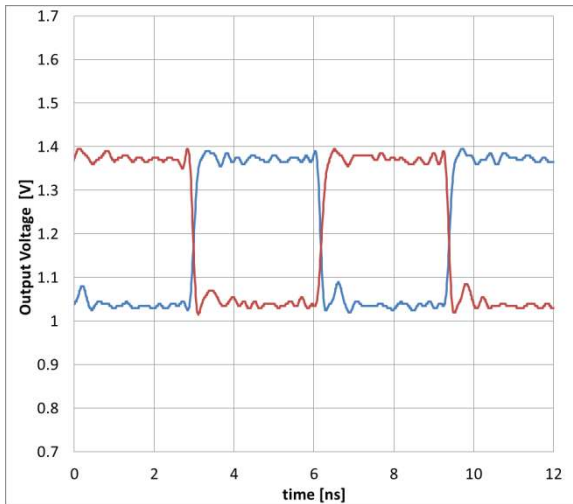

Figure 21. 156.25MHz LVDS

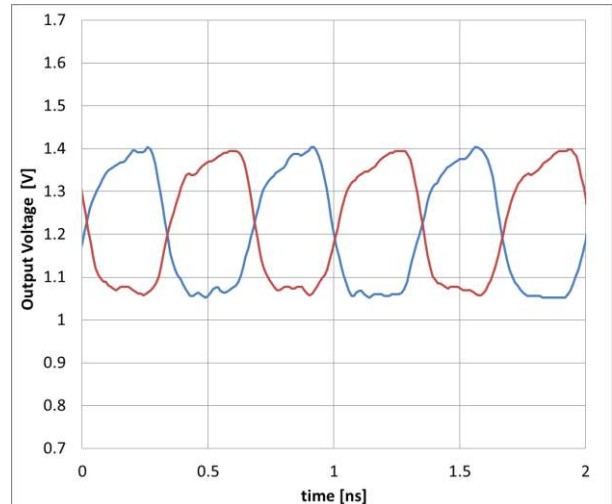

Figure 22. 1.5GHz LVDS

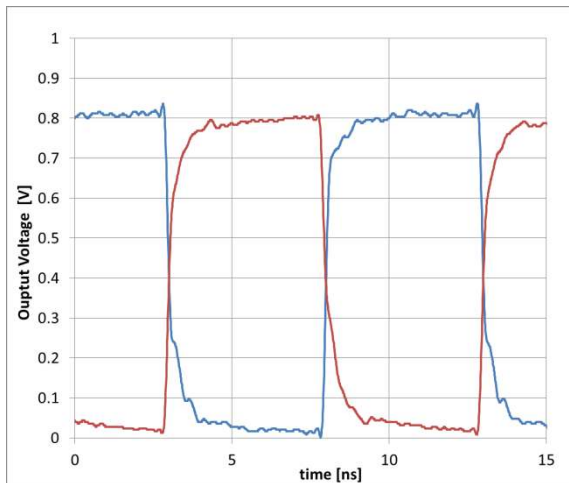

Figure 23. 100MHz HCSSL

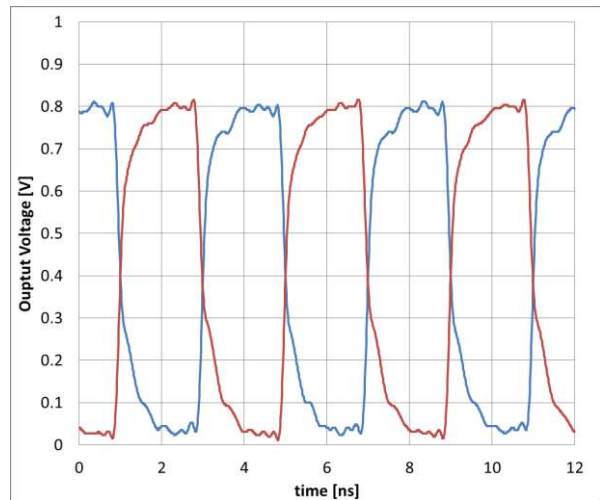

Figure 24. 250MHz HCSSL

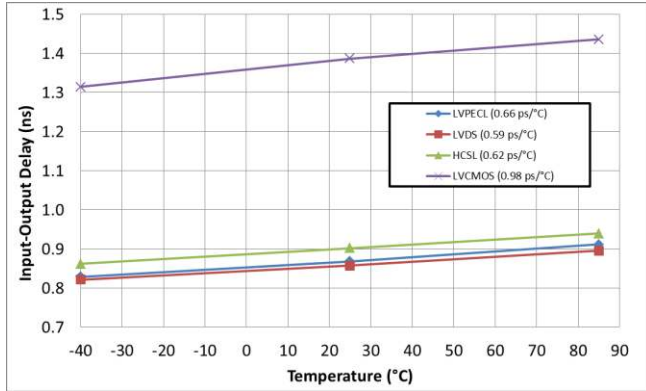

Figure 25. I/O delay vs temperature

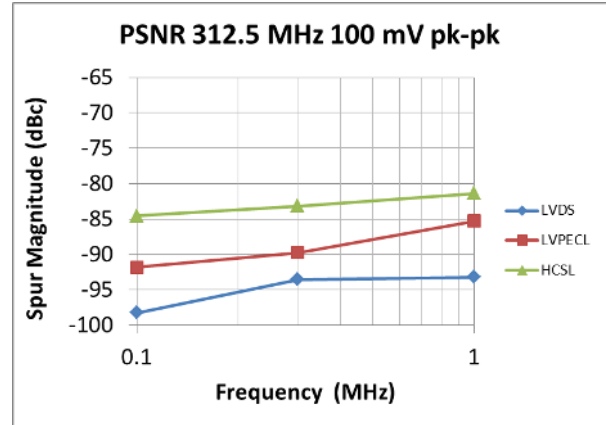

Figure 26. PSNR vs noise frequency

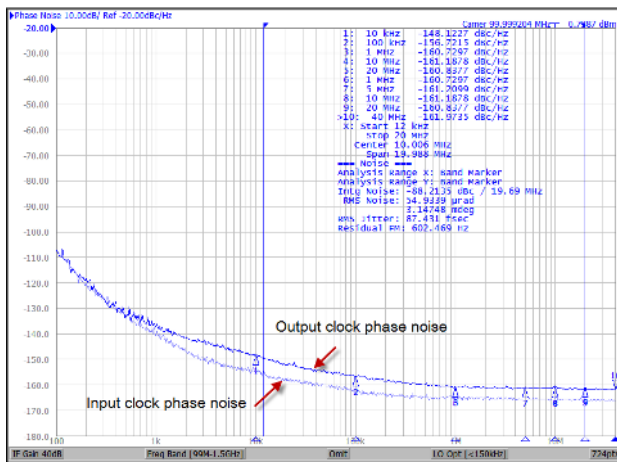

Figure 27. 100MHz LVPECL Phase Noise

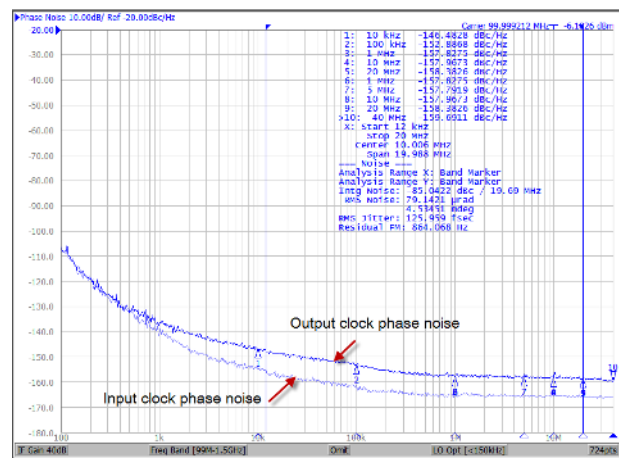

Figure 28. 100MHz LVDS Phase Noise

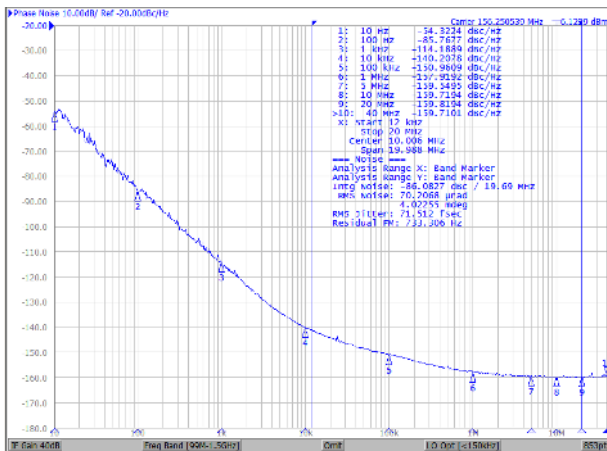

Figure 29. 156.25MHz LVDS Phase Noise in Xtal mode

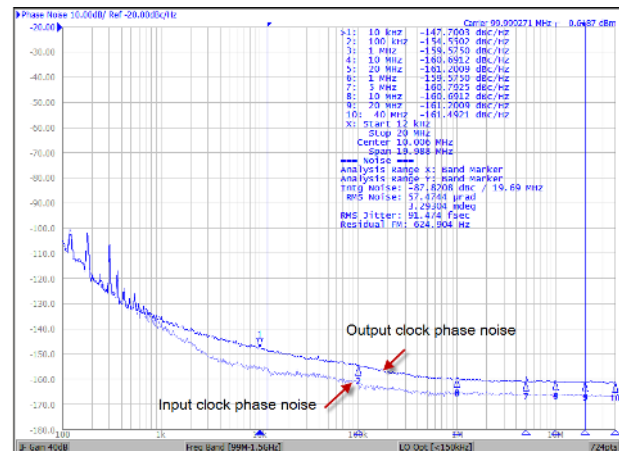

Figure 30. 100MHz HCSL Phase Noise

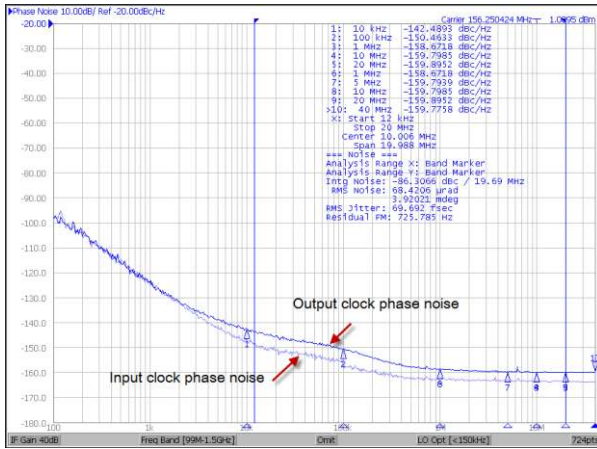

Figure 31. 156.25MHz LVPECL Phase Noise

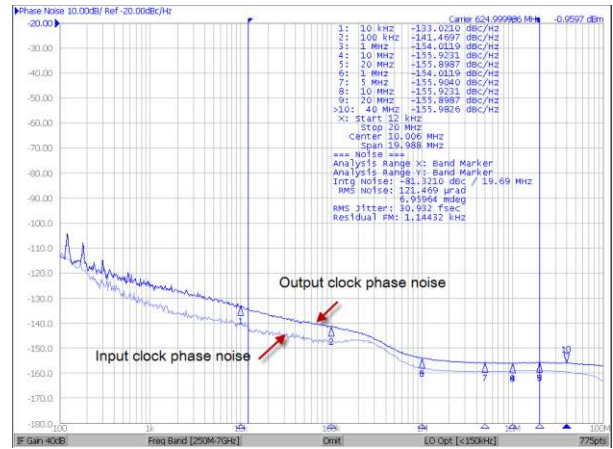

Figure 32. 625MHz LVPECL Phase Noise

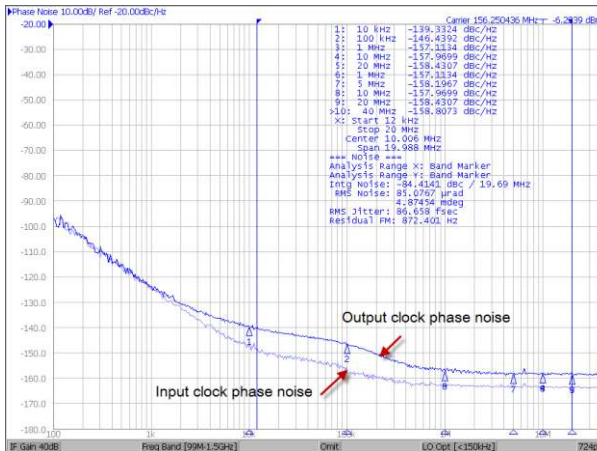

Figure 33. 156.25MHz LVDS Phase Noise

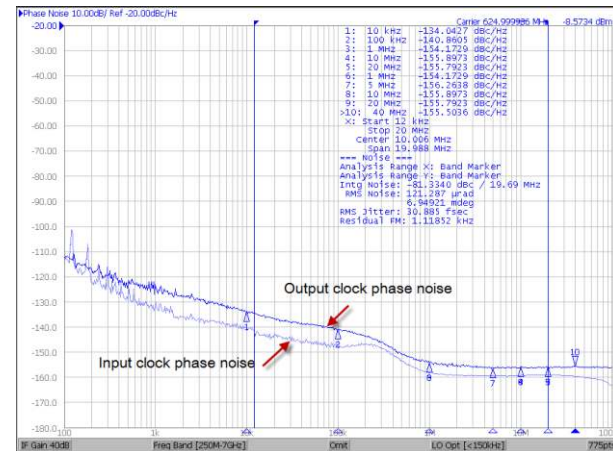

Figure 34. 625MHz LVDS Phase Noise

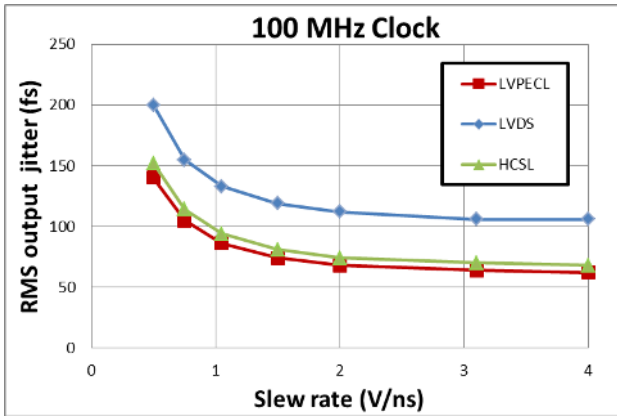

Figure 35. Output RMS jitter (12kHz to 20MHz) vs input clock slew-rate

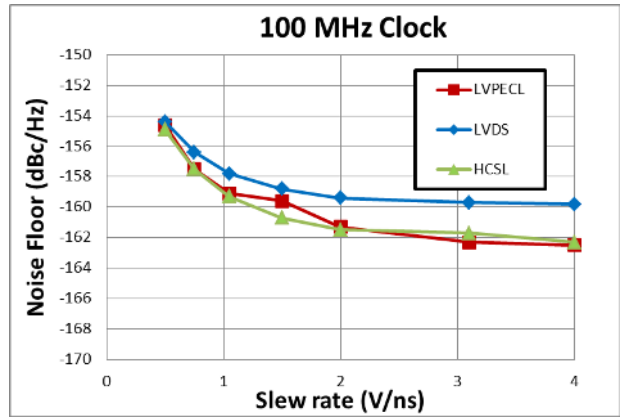

Figure 36. Output clock noise floor vs input clock slew-rate

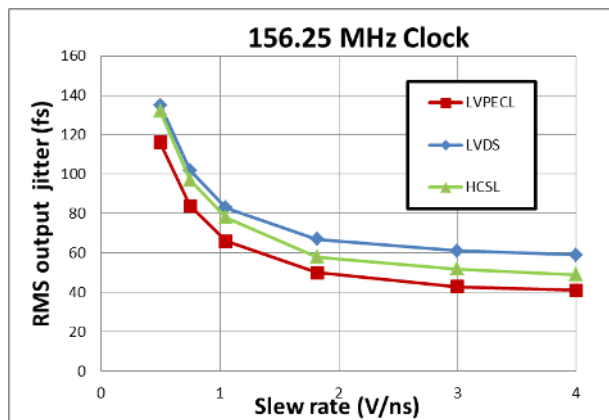

Figure 37. Output RMS jitter (12kHz to 20MHz) vs input clock slew-rate

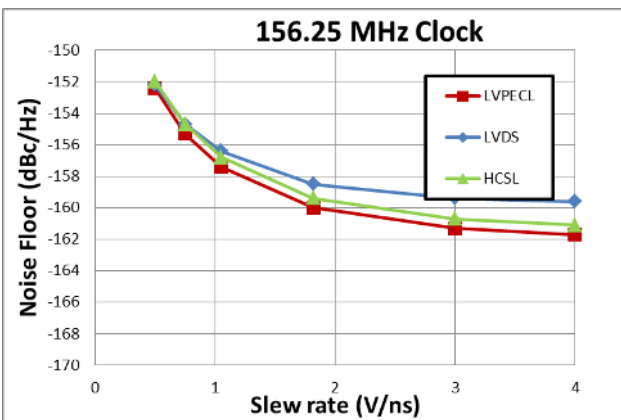

Figure 38. Output clock noise floor vs input clock slew-rate

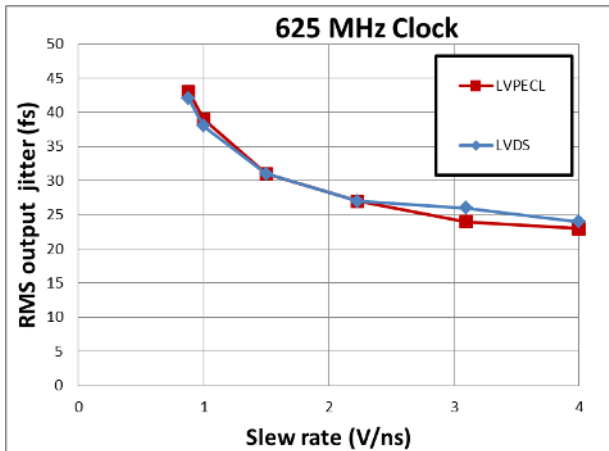

Figure 39. Output RMS jitter (12kHz to 20MHz) vs input clock slew-rate

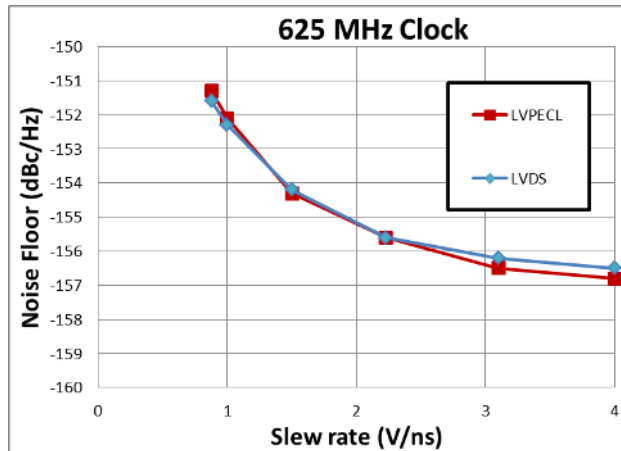

Figure 40. Output clock noise floor vs input clock slew-rate

Register Map

The device is controlled by accessing registers through the serial interface. The following table provides a summary of the registers available for the configuration of the device.

Table 4 Register Map

Address SPI A[6:0] Hex (0x)	Name	Data D[7:0]
00	XTALBG	xtal_buf_gain[7:0]
01	XTALDL	xtal_drive_level[7:0]
02	XTALLC	xtal_load_cap[7:0]
03	XTALNR	xtal_normal_run
04	-	Not used
05	INSEL	input_select[1:0]
06	OUTLOW	output_drive_low
07	DRVTYPEA	{driver_type[5:4], 4'bxxxx} (differential output 1 and 0)
08	-	Not used
09	DRVTYPEB	{driver_type[17:12], 2'bxx} (differential output 4, 3, and 2)
0A	-	Not used
0B	CMOSDIV	cmos_div[2:0] (cmos)
0C	CMOSOUTEN	output_enable (cmos)
0D	CMOSDRVSTR	driver_strength (cmos)
0E	-	Not used
0F/11	Reserved	Leave as default
11	DEVID	Device ID
12 to 1F	Reserved	Leave as default

Address	0x00			Hex
XTALBG		XTAL Buffer Gain		
Bit	Name	Description	Type	Reset
7:0	xtal_buf_gain[7:0]	<p>Programs crystal buffer (inverting amplifier) gain. Every bit pair (bits: 01, 23, 45, 67) of this register correspond to additional equal gain block which can be added (bits set) or removed (bits cleared). Minimum gain is 0x00 (default) and 0xFF is maximum gain. When reference input mode is "bypass XTAL mode" or "differential input modes" with HIGH xtal_normal_run bit, the buffer is disabled and follows "Input Selection". When xtal_normal_run bit is LOW, XTAL buffer is in the "xtal forced run" mode and keep running.</p> <p>8'b0000_0000: default crystal buffer strength. 8'b0000_0011: enable additional buffer strength 8'b0000_1100: enable additional buffer strength 8'b0011_0000: enable additional buffer strength 8'b1100_0000: enable additional buffer strength</p>	RW	FF

Address	0x01			Hex
XTALDL		XTAL Drive Level		
Bit	Name	Description	Type	Reset
7:0	xtal_drive_level[7:0]	<p>Internal damping resistance of crystal circuit to limit external crystal's drive level uW. The value of damping resistor is determined by crystal's motion resistance of crystal's equivalent circuit. Drive level should be lower than crystal manufacturer's specification. Crystal's equivalent values should be requested to the manufacturer, (motion resistance and shunt capacitance). The selected resistors are connected to XOUT. Multiple bit combinations available by 7-bit control. Because they use parallel connections, 0xFF is the smallest resistance and 0x01 is the highest resistance.</p> <p>8'b0000_0000: disable all resistors 8'b0000_0001: 312 Ohm resistor 8'b0000_0010: 161 Ohm resistor 8'b0000_0100: 84 Ohm resistor 8'b0000_1000: 42 Ohm resistor 8'b0001_0000: 21 Ohm resistor 8'b0010_0000: 10.5 Ohm resistor 8'b0100_0000: 0 Ohm connection 8'b1000_0000: not used</p>	RW	04

Address	0x02			Hex
XTALLC		XTAL Load Capacitance 0		
Bit	Name	Description	Type	Reset
7:0	xtal_load_cap[7:0]	<p>Internal load capacitance of crystal circuit (0 pF to 21.75 pF with the resolution of 0.25 pF). XIN and XOUT have each capacitor connected to GND. Multiple bit combinations available between 8 capacitors.</p> <p>8'b0000_0000: disable all xtal load capacitors 8'b0000_0001: enable capacitor 0.25 pF 8'b0000_0010: enable capacitor 0.5 pF 8'b0000_0100: enable capacitor 1 pF 8'b0000_1000: enable capacitor 2 pF 8'b0001_0000: enable capacitor 2 pF 8'b0010_0000: enable capacitor 4 pF 8'b0100_0000: enable capacitor 4 pF 8'b1000_0000: enable capacitor 8 pF</p>	RW	40

Address	0x03			Bin
XTALNR		XTAL Normal Run		
Bit	Name	Description	Type	Reset
7:1	Reserved	Reserved	R	1111111
0	xtal_normal_run	<p>When this bit is set high crystal oscillator circuit is running only if input_select[1:0] register at address 0x05 selects crystal mode (2'b10). This value is recommended because it provides best jitter performance--XO circuit is running only when it is needed.</p> <p>When this bit is set low the crystal oscillator will keep running even if crystal oscillator is not selected in input_select[1:0] register at address 0x05. This mode should only be used when fast switching between input references and crystal oscillator is required.</p>	RW	1

Address	0x05			Bin
INSEL		Input Select Register		
Bit	Name	Description	Type	Reset
7:2	Reserved	Reserved	R	111111
1:0	input_select[1:0]	Input reference clock selection. Proper external coupling and termination are required. 2'b00: differential input from IN0_p and IN0_n 2'b01: differential input from IN1_p and IN1_n 2'b10: fundamental XTAL mode with XIN and XOUT (Use internal crystal oscillator circuits) or XTAL overdrive mode (single-ended clock signal fed to XIN) 2'b11: XTAL bypass mode (single-ended clock signal with XIN and disabled internal crystal buffer circuit in the analog block)	RW	00

Address	0x06			Hex
OUTLOW		Output Drive Low		
Bit	Name	Description	Type	Reset
7:1	Reserved	Reserved	R	1111111
0	output_drive_low	Forces all disabled outputs to drive low in LVPECL mode. 1'b1: All differential outputs that are disabled in DRVTYPE registers (addresses 0x07, 0x08, 0x09 and 0x0A) will drive low in LVPECL mode. Hence, LVPECL biasing/termination resistors are required for proper functionality of this feature. 1'b0: This feature is ignored and all outputs that are disabled in DRVTYPE registers (addresses 0x07, 0x08, 0x09 and 0x0A) will stay in disabled (high-Z) mode.	RW	0

Address	0x07			Bin
DRVTYPEA		Output Type Select Bank-A		
Bit	Name	Description	Type	Reset
7:6	driver_type[7:6]	Output driver type of differential OUT1. The same description as for OUT0.	RW	11
4:3	driver_type[5:4]	Output driver type of differential OUT0. 2'b00: LVPECL outputs 2'b01: LVDS outputs 2'b10: HCSL outputs 2'b11: outputs disabled (Disabled state is dependent on "out_drive_low" control bit of register OUTLOW.)	RW	11
3:0	Reserved	Reserved	RO	X

Address	0x09			Bin
DRVTYPEB		Output Type Select Bank-B		
Bit	Name	Description	Type	Reset
7:6	driver_type[17:16]	Output driver type of differential OUT4. The same description as for OUT0.	RW	11
5:4	driver_type[15:14]	Output driver type of differential OUT3. The same description as for OUT0.	RW	11
3:2	driver_type[13:12]	Output driver type of differential OUT2. The same description as for OUT0.	RW	11
1:0	Reserved	Reserved	RO	X

Address	0x0B			Bin
CMOSDIV		CMOS Output Divider		
Bit	Name	Description	Type	Reset
7:3	Reserved	Reserved	R	11111
2:0	cmos_div[2:0]	Integer divider from a selected input reference clock for OUT_LVCMOS (1 to 8). 3'b000: division ratio = 1 3'b001: division ratio = 2 3'b010: division ratio = 3 3'b011: division ratio = 4 3'b100: division ratio = 5 3'b101: division ratio = 6 3'b110: division ratio = 7 3'b111: division ratio = 8	RW	000

Address	0x0C			Bin
CMOSOUTEN		LVCMOS Output Enable		
Bit	Name	Description	Type	Reset
7:1	Reserved	Reserved	R	1111111
0	output_enable	Output enable of OUT_LVCMOS. Disabled state is dependent on "out_drive_low" control bit. 1'b0: Disable OUT_LVCMOS output 1'b1: Enable OUT_LVCMOS output	RW	1

Address	0x0D			Bin
CMOSDRVSTR		CMOS Driver Strength		
Bit	Name	Description	Type	Reset
7:1	Reserved	Reserved	R	1111111
0	driver_strength	OUT_LVCMOS output strength. 1'b0: low strength 1'b1: high strength	RW	0

Address	0x11			Bin
DEVID	Device Identification			
Bit	Name	Description	Type	Reset
7	Unused	Unused	R	0
6:5	Reserved	Reserved	R	11
4:0	dev_id	Device ID 5'h02: ZL40235	RO	00010

AC and DC Electrical Characteristics

Absolute Maximum Ratings

Table 5 Absolute Maximum Ratings*

	Parameter	Sym.	Min.	Typ.	Max.	Units	Notes
1	Supply voltage (3.3V)	V_{DD}/V_{DDO}	-0.5		4.6	V	
2	Supply voltage (2.5V)	V_{DD}/V_{DDO}	-0.5		3.5	V	
3	Storage temperature	T_{ST}	-55		125	°C	

* Exceeding these values may cause permanent damage

* Functional operation under these conditions is not implied

* Voltages are with respect to ground (GND) unless otherwise stated

Recommended Operating Conditions

Table 6 Recommended Operating Conditions*

	Characteristics	Sym.	Min.	Typ.	Max.	Units	Notes
1	Supply voltage 3.3V	$V_{DD}/V_{DDO}/V_{DD_LVCMOS}$	3.135	3.30	3.465	V	
2	Supply voltage 2.5V	$V_{DD}/V_{DDO}/V_{DD_LVCMOS}$	2.375	2.50	2.625	V	
3	Supply voltage 1.8V	V_{DD_LVCMOS}	1.6	1.8V	2	V	
4	Supply voltage 1.5V	V_{DD_LVCMOS}	1.35	1.5	1.65	V	
5	Operating temperature	T_A	-40	25	85	°C	
6	Input voltage	V_{DD-IN}	- 0.3		$V_{DD} + 0.3$	V	

* Voltages are with respect to ground (GND) unless otherwise stated

* The device core supports two power supply modes (3.3V and 2.5V)

Table 7 Current consumption

	Characteristics	Sym.	Min.	Typ.	Max.	Units	Notes
1	Core device current (all outputs and XTAL disabled)	$I_{s_3.3V}$		163	197	mA	$V_{DD} = 3.3V + 5\%$
		$I_{s_2.5V}$		153	187	mA	$V_{DD} = 2.5V + 5\%$
2	Core device current (all outputs disabled) XTAL circuit enabled with 25MHz Crystal connected between XIN and XOUT	$I_{DD_XTAL_3.3V}$		128	154	mA	$V_{DD} = 3.3V + 5\%$
		$I_{DD_XTAL_2.5V}$		124	150	mA	$V_{DD} = 2.5V + 5\%$
3	Common output current	$I_{DD_CM_3.3V}$		13.44	15.05	mA	$V_{DDO} = 3.3V + 5\%$
		$I_{DD_CM_2.5V}$		12.18	13.65	mA	$V_{DDO} = 2.5V + 5\%$
4	Dynamic LVCMOS current for high strength output (f = 100MHz) Needs to be scaled for different frequencies by f/100MHz	$I_{DD_3.3V}$		4.08	4.74	mA	$V_{DDO} = 3.3V + 5\%$
		$I_{DD_2.5V}$		2.90	3.29	mA	$V_{DDO} = 2.5V + 5\%$
5	Dynamic LVCMOS current for low strength output (f = 100MHz) Needs to be scaled for different frequencies by f/100MHz	$I_{DD_3.3V}$		2.38	2.68	mA	$V_{DDO} = 3.3V + 5\%$
		$I_{DD_2.5V}$		1.74	1.96	mA	$V_{DDO} = 2.5V + 5\%$
6	Current dissipation per LVPECL output	$I_{DD_LVPECL_3.3V}$		19.36	23.26	mA	$V_{DDO} = 3.3V + 5\%$
		$I_{DD_LVPECL_2.5V}$		19.38	22.17	mA	$V_{DDO} = 2.5V + 5\%$
7	Current dissipation per LVDS output	$I_{DD_LVDSL_3.3V}$		6.73	8.00	mA	$V_{DDO} = 3.3V + 5\%$
		$I_{DD_LVDS_2.5V}$		6.87	7.83	mA	$V_{DDO} = 2.5V + 5\%$
8	Current dissipation per HCSL output	$I_{DD_HCSL_3.3V}$		16.43	19.87	mA	$V_{DDO} = 3.3V + 5\%$
		$I_{DD_HCSL_2.5V}$		17.14	19.18	mA	$V_{DDO} = 2.5V + 5\%$

Table 8 Input Characteristics*

	Characteristics	Sym.	Min.	Typ.	Max.	Units	Notes
1	CMOS high-level input voltage for control inputs	V_{CIH}	1.05			V	
2	CMOS low-level input voltage for control inputs	V_{CIL}			0.45	V	
3	CMOS input leakage current for control inputs (includes current due to pull down resistors)	I_{IL}	-25		50	μ A	$V_i = V_{DD}$ or 0 V
4	Differential input common mode voltage for IN0_p/n and IN1_p/n	V_{CM}	1		2	V	
5	Differential input voltage difference for IN0_p/n and IN1_p/n $f \leq 1$ GHz **	V_{ID}	0.15		1.3	V	
6	Differential input voltage difference for IN0_p/n and IN1_p/n for 1 GHz $< f \leq 1.6$ GHz **	V_{ID}	0.35		1.3	V	
7	Differential input leakage current for IN0_p/n and IN1_p/n (includes current due to pull-up and pull-down resistors)	I_{IL}	-150		150	μ A	$V_i = 2$ V or 0V
8	Single ended input voltage for IN0_p and IN1_p	V_{SI}	-0.3		2.7	V	$V_{DD} = 3.3$ V or 2.5V
9	Single ended input common mode voltage (IN0_p/n and IN1_p/n)	V_{SIC}	1		2	V	$V_{DD} = 3.3$ V or 2.5V
10	Single ended input voltage swing for IN0_p and IN1_p	V_{SID}	0.3		1.3	V	$V_{DD} = 3.3$ V or 2.5V
11	Input frequency (differential)	f_{IN}	0		1600	MHz	
12	Input frequency (LVCMOS)	f_{IN_CMOS}	0		250	MHz	
13	Input duty cycle	dc	35%		65%		
14	Input slew rate	slew		2		V/ns	
15	Input pull-up/ pull-down resistance	R_{PU}/R_{PD}		60k Ω			
16	Input pull-down resistance for INx_p	R_{PD}		30k Ω			
17	Input multiplexer isolation IN0_p/n to IN1_p/n and vice versa Power on both inputs 0dBm, $f_{OFFSET} > 50$ kHz	Iso		-84		dBc	$f_{IN} = 100$ MHz
				-82			$f_{IN} = 200$ MHz
				-71			$f_{IN} = 400$ MHz
				-67			$f_{IN} = 800$ MHz

* Values are over Recommended Operating Conditions

* Values are over all two power supply modes ($V_{DD} = 3.3$ V and $V_{DD} = 2.5$ V)

* Input mux isolation is measured as amplitude of f_{OFFSET} spur in dBc on the output clock phase noise plot

**Input differential voltage is calculated as $V_{ID} = V_{IH} - V_{IL}$ where V_{IH} and V_{IL} are input voltage high and low respectively. It should not be confused with $V_{ID} = 2 * (V_{IH} - V_{IL})$ used in some datasheets. Please refer to Figure 41.

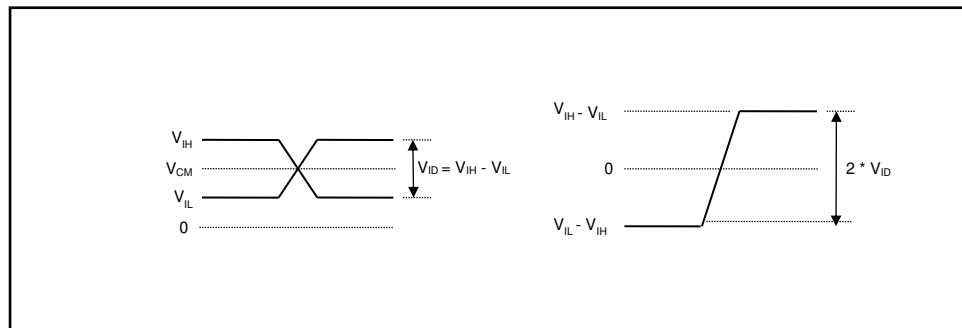

Figure 41. Differential Input Voltage Levels

Table 9 Crystal Oscillator Characteristics*

	Characteristics	Sym.	Min.	Typ.	Max.	Units	Notes
1	Mode of oscillation	mode	Fundamental				
2	Frequency	f	8		160	MHz	
3	On chip load capacitance in SPI controlled mode	C _L	0		21.75	pF	Programmable
4	On chip load capacitance in pin controlled mode			4		pF	Fixed
5	On chip series resistor in SPI controlled mode	R _S	0		312	Ω	Programmable
6	On chip series resistor in pin controlled mode			84		Ω	Fixed
7	On chip shunt resistor	R		500		kΩ	
8	Frequency in overdrive mode ⁽¹⁾	f _{OV}	0.1		250	MHz	Functional but may not meet AC parameters Minimum depends on AC coupling Capacitor (0.1μF assumed)
9	Frequency in bypass mode ⁽²⁾	f _{BP}	0		250	MHz	Functional but may not meet AC parameters

* Values are over Recommended Operating Conditions

* Values are over all two power supply modes (V_{DD} = 3.3V and V_{DD} = 2.5V)

(1) Maximum input level is 2V

(2) Maximum output level is VDD

Table 10 Power Supply Rejection Ratio for VDD = VDDO = 3.3V*

	Characteristics	Sym.	Min.	Typ.	Max.	Units	Notes
1	PSRR for LVPECL output	PSRR _{LVPECL}		-71.75		dBc	f _{IN} = 156.25 MHz
				-84.45			f _{IN} = 312.5 MHz
				-82.11			f _{IN} = 625 MHz
2	PSRR for LVDS output	PSRR _{LVDS}		-95.16		dBc	f _{IN} = 156.25 MHz
				-97.77			f _{IN} = 312.5 MHz
				-79.23			f _{IN} = 625 MHz
3	PSRR for HCSSL output	PSRR _{HCSSL}		-77.15		dBc	f _{IN} = 100 MHz
				-76.75			f _{IN} = 156.25 MHz
				-80.44			f _{IN} = 312.5 MHz

* Values are over Recommended Operating Conditions

* Noise injected to VDDO power supply with frequency 100 kHz and amplitude 100 mVpp

* PSRR is measured as amplitude of 100 kHz spur in dBc on the output clock phase noise plot

Table 11 Power Supply Rejection Ratio for VDD = VDDO = 2.5V*

	Characteristics	Sym.	Min.	Typ.	Max.	Units	Notes
1	PSRR for LVPECL output	PSRR _{LVPECL}		-73.68		dBc	f _{IN} = 156.25 MHz
				-78.88			f _{IN} = 312.5 MHz
				-71.82			f _{IN} = 625 MHz
2	PSRR for LVDS output	PSRR _{LVDS}		-90.04		dBc	f _{IN} = 156.25 MHz
				-79.99			f _{IN} = 312.5 MHz
				-73.45			f _{IN} = 625 MHz
3	PSRR for HCSL output	PSRR _{HCSL}		-92.16		dBc	f _{IN} = 100 MHz
				-74.08			f _{IN} = 156.25 MHz
				-91.88			f _{IN} = 312.5 MHz

* Values are over Recommended Operating Conditions

* Noise injected to VDDO power supply with frequency 100 kHz and amplitude 100 mVpp

* PSRR is measured as amplitude of 100 kHz spur in dBc on the output clock phase noise plot

Table 12 LVCMOS Output Characteristics for VDDO = 3.3V*

	Characteristics	Sym.	Min.	Typ.	Max.	Units	Notes
1	Output high voltage (1mA load)	V _{OH}	VDDO-0.1			V	DC Measurement
2	Output low voltage (1mA load)	V _{OL}			0.1	V	DC Measurement
3	Output High Current (Load adjusted to Vout = VDDO/2)	I _{OH}		30		mA	DC Measurement
4	Output Low Current (Load adjusted to Vout = VDDO/2)	I _{OL}		34		mA	DC Measurement
5	Output impedance	R _O		15		Ω	DC Measurement
6	Rise time (20% to 80%)	t _r		220	310	ps	
7	Fall time (20% to 80%)	t _f		320	365	ps	
8	Output frequency	F _O	0		250	MHz	
9	Input to output delay	t _{IOD}	1.07	1.28	2.07	ns	
10	Output enable time	t _{EN}			3	cycles	
11	Output disable time	T _{DIS}			3	cycles	
12	Additive RMS jitter in 1MHz to 5MHz band	T _{L1M_5M}		46	80	fs	Input Clock 25MHz
13	Additive RMS jitter in 12kHz to 5MHz band	T _{L12K_5M}		56	90	fs	Input Clock 25MHz
14	Additive RMS jitter in 1MHz to 20MHz band	T _{L1M_20M}		60	79	fs	Input Clock 125MHz
15	Additive RMS jitter in 12kHz to 20MHz band	T _{L12K_20M}		65	86	fs	Input Clock 125MHz
16	Additive RMS jitter in 1MHz to 20MHz band	T _{L1M_20M}		61	94	fs	Input Clock 156.25MHz
17	Additive RMS jitter in 12kHz to 20MHz band	T _{L12K_20M}		66	100	fs	Input Clock 156.25MHz
18	Noise floor	N _F		-165	-162	dBc/Hz	Input clock: 25 MHz
19				-160	-156	dBc/Hz	Input clock: 125 MHz
20				-158	-153	dBc/Hz	Input clock: 156.25 MHz

* Values are over Recommended Operating Conditions

Table 13 LVCMOS Output Characteristics for VDDO = 2.5V*

	Characteristics	Sym.	Min.	Typ.	Max.	Units	Notes
1	Output high voltage (1mA load)	V_{OH}	VDDO-0.1			V	DC Measurement
2	Output low voltage (1mA load)	V_{OL}			0.1	V	DC Measurement
3	Output High Current (Load adjusted to $V_{out} = VDDO/2$)	I_{OH}		21		mA	DC Measurement
4	Output Low Current (Load adjusted to $V_{out} = VDDO/2$)	I_{OL}		25		mA	DC Measurement
5	Output impedance	R_o		15		Ω	DC Measurement
6	Rise time (20% to 80%)	t_r		225	310	ps	
7	Fall time (20% to 80%)	t_f		320	365	ps	
8	Output frequency	F_o	0		250	MHz	
9	Input to output delay	t_{IOD}	1.10	1.41	2.30	ns	
10	Output enable time	t_{EN}			3	cycles	
11	Output disable time	T_{DIS}			3	cycles	
12	Additive RMS jitter in 1MHz to 5MHz band	$T_{j,1M,5M}$		51	104	fs	Input Clock 25MHz
13	Additive RMS jitter in 12kHz to 5MHz band	$T_{j,12k,5M}$		62	111	fs	Input Clock 25MHz
14	Additive RMS jitter in 1MHz to 20MHz band	$T_{j,1M,20M}$		64	81	fs	Input Clock 125MHz
15	Additive RMS jitter in 12kHz to 20MHz band	$T_{j,12k,20M}$		70	88	fs	Input Clock 125MHz
16	Additive RMS jitter in 1MHz to 20MHz band	$T_{j,1M,20M}$		62	94	fs	Input Clock 156.25MHz
17	Additive RMS jitter in 12kHz to 20MHz band	$T_{j,12k,20M}$		68	100	fs	Input Clock 156.25MHz
18	Noise floor	N_F		-164	-161	dBc/Hz	Input clock: 25 MHz
19				-159	-155	dBc/Hz	Input clock: 125 MHz
20				-158	-153	dBc/Hz	Input clock: 156.25 MHz

* Values are over Recommended Operating Conditions

Table 14 LVPECL Output Characteristics for VDDO = 3.3V*

	Characteristics	Sym.	Min.	Typ.	Max.	Units	Notes
1	Output high voltage	V_{LVPECL_OH}	1.9	2.08	2.4	V	DC Measurement
2	Output low voltage	V_{LVPECL_OL}	1.2	1.36	1.7	V	DC Measurement
3	Output differential swing**	V_{LVPECL_SW}	0.6	0.72	0.9	V	DC Measurement
4	Variation of V_{LVPECL_SW} for complementary output states	ΔV_{LVPECL_SW}	0	0.02	0.07	V	
5	Common mode output	V_{CM}	1.6	1.72	2.1	V	
7	Output frequency when $V_{LVPECL_SW} \geq 0.6V$	$F_{MAX_0.6VSW}$			800	MHz	
8	Output frequency when $V_{LVPECL_SW} \geq 0.4V$	$F_{MAX_0.4VSW}$			1600	MHz	
9	Rise or fall time (20% to 80%)	t_r, t_f		110	170	ps	
10	Output frequency	F_o	0		1600	MHz	
11	Output to output skew	t_{OOSK}			40	ps	
12	Device to device output skew	t_{DOOSK}			120	ps	
13	Input to output delay	t_{IOD}	0.73	0.87	1.1	ns	
14	Output enable time	t_{EN}			3	cycles	
15	Output disable time	t_{DIS}			3	cycles	
16	Additive RMS jitter in 1MHz to 20MHz band	$T_{L_1M_20M}$		68	96	fs	Input clock: 100 MHz
				50	64	fs	Input clock: 156.25MHz
				20	32	fs	Input clock: 625 MHz
17	Additive RMS jitter in 12kHz to 20MHz band	$T_{L_12k_20M}$		71	101	fs	Input clock: 100 MHz
				55	70	fs	Input clock: 156.25MHz
				25	39	fs	Input clock: 625 MHz
18	Noise floor	N_F		-161	-159	dBc/Hz	Input clock: 100 MHz
				-160	-155	dBc/Hz	Input clock: 156.25 MHz
				-155	-151	dBc/Hz	Input clock: 625 MHz

* Values are over Recommended Operating Conditions

**Output differential swing is calculated as $V_{SW} = V_{OH} - V_{OL}$. It should not be confused with $V_{SW} = 2 * (V_{OH} - V_{OL})$ used in some datasheets. . Please refer to Figure 42.

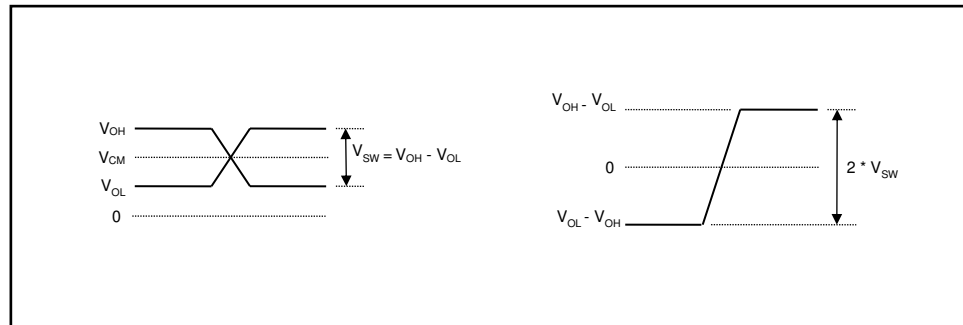

Figure 42. Differential Output Voltage Levels

Table 15 LVPECL Output Characteristics for VDDO = 2.5V*

	Characteristics	Sym.	Min.	Typ.	Max.	Units	Notes
1	Output high voltage	V_{LVPECL_OH}	1.1	1.28	1.7	V	DC Measurement
2	Output low voltage	V_{LVPECL_OL}	0.4	0.57	0.9	V	DC Measurement
3	Output differential swing**	V_{LVPECL_SW}	0.6	0.71	0.9	V	DC Measurement
4	Variation of V_{LVPECL_SW} for complementary output states	ΔV_{LVPECL_SW}	0	0.02	0.05	V	
5	Common mode output	V_{CM}	0.8	0.92	1.2	V	
7	Output frequency when $V_{LVPECL_SW} \geq 0.6V$	$F_{MAX_0.6VSW}$			800	MHz	
8	Output frequency when $V_{LVPECL_SW} \geq 0.4V$	$F_{MAX_0.4VSW}$			1600	MHz	
9	Rise or fall time (20% to 80%)	t_r, t_f		120	170	ps	
10	Output frequency	F_o	0		1600	MHz	
11	Output to output skew	t_{OOSK}			40	ps	
12	Device to device output skew	t_{DOOSK}			120	ps	
13	Input to output delay	t_{IOD}	0.75	0.87	1.1	ns	
14	Output enable time	t_{EN}			3	cycles	
15	Output disable time	t_{DIS}			3	cycles	
16	Additive RMS jitter in 1MHz to 20MHz band	T_{L1M_20M}		65	91	fs	Input clock: 100 MHz
				50	64	fs	Input clock: 156.25MHz
				20	30	fs	Input clock: 625 MHz
17	Additive RMS jitter in 12kHz to 20MHz band	T_{L12k_20M}		69	99	fs	Input clock: 100 MHz
				54	75	fs	Input clock: 156.25MHz
				26	41	fs	Input clock: 625 MHz
18	Noise floor	N_F		-161	-159	dBc/Hz	Input clock: 100 MHz
				-160	-156	dBc/Hz	Input clock: 156.25 MHz
				-155	-151	dBc/Hz	Input clock: 625 MHz

* Values are over Recommended Operating Conditions

**Output differential swing is calculated as $V_{SW} = V_{OH} - V_{OL}$. It should not be confused with $V_{SW} = 2 * (V_{OH} - V_{OL})$ used in some datasheets. Please refer to Figure 42.

Table 16 LVDS Outputs for VDDO = 3.3V*

	Characteristics	Sym.	Min.	Typ.	Max.	Units	Notes
1	Output high voltage	V_{LVDS_OH}	1.3	1.39	1.47	V	DC Measurement
2	Output low voltage	V_{LVDS_OL}	1.0	1.07	1.15	V	DC Measurement
3	Output differential swing**	V_{LVDS_SW}	0.25	0.32	0.39	V	DC Measurement
4	Variation of V_{LVDS_SW} for complementary output states	ΔV_{LVDS_SW}	0	0.002	0.01	V	
5	Common mode output	V_{CM}	1.15	1.23	1.3	V	
6	Variation of V_{CM} for complementary output states	ΔV_{CM}	0	0.001	0.01	V	
7	Output frequency when $V_{LVDS_SW} \geq 250mV$	$F_{MAX_0.25VSW}$			800	MHz	
8	Output frequency when $V_{LVDS_SW} \geq 200mV$	$F_{MAX_0.2VSW}$			1600	MHz	
9	Rise or fall time (20% to 80%)	t_r, t_f		110	170	ps	
10	Output frequency	F_O	0		1600	MHz	
11	Output to output skew	t_{OOSK}			20	ps	
12	Device to device output skew	t_{DOOSK}			130	ps	
13	Input to output delay	t_{IOD}	0.76	0.86	1.1	ns	
14	Output Short Circuit Current Single Ended	I_S	-24		24	mA	Single ended outputs shorted to GND
15	Output Short Circuit Current Differential	I_{SD}	-24		24	mA	Complementary outputs shorted
16	Output enable time	t_{EN}			3	cycles	
17	Output disable time	t_{DIS}			3	cycles	
18	Additive RMS jitter in 1MHz to 20MHz band	T_{L1M_20M}		110	144	fs	Input clock: 100 MHz
				63	81	fs	Input clock: 156.25MHz
				21	33	fs	Input clock: 625 MHz
19	Additive RMS jitter in 12kHz to 20MHz band	T_{L12k_20M}		115	150	fs	Input clock: 100 MHz
				73	102	fs	Input clock: 156.25MHz
				26	40	fs	Input clock: 625 MHz
20	Noise floor	N_F		-158	-156	dBc/Hz	Input clock: 100 MHz
				-158	-155	dBc/Hz	Input clock: 156.25 MHz
				-154	-151	dBc/Hz	Input clock: 625 MHz

* Values are over Recommended Operating Conditions

**Output differential swing is calculated as $V_{SW} = V_{OH} - V_{OL}$. It should not be confused with $V_{SW} = 2 * (V_{OH} - V_{OL})$ used in some datasheets. Please refer to Figure 42.

Table 17 LVDS Outputs for VDDO = 2.5V*

	Characteristics	Sym.	Min.	Typ.	Max.	Units	Notes
1	Output high voltage	V_{LVDS_OH}	1.3	1.4	1.5	V	DC Measurement
2	Output low voltage	V_{LVDS_OL}	0.97	1.05	1.13	V	DC Measurement
3	Output differential swing**	V_{LVDS_SW}	0.25	0.35	0.44	V	DC Measurement
4	Variation of V_{LVDS_SW} for complementary output states	ΔV_{LVDS_SW}	0	0.001	0.01	V	
5	Common mode output	V_{CM}	1.15	1.23	1.3	V	
6	Variation of V_{CM} for complementary output states	ΔV_{CM}	0	0.001	0.01	V	
7	Output frequency when $V_{LVDS_SW} \geq 250mV$	$F_{MAX_0.25VSW}$			800	MHz	
8	Output frequency when $V_{LVDS_SW} \geq 200mV$	$F_{MAX_0.2VSW}$			1600	MHz	
9	Rise or fall time (20% to 80%)	t_r, t_f		110	170	ps	
10	Output frequency	F_O	0		1600	MHz	
11	Output to output skew	t_{OOSK}			20	ps	
12	Device to device output skew	t_{DOOSK}			130	ps	
13	Input to output delay	t_{IOD}	0.78	0.86	1.12	ns	
14	Output Short Circuit Current Single Ended	I_S	-24		24	mA	Single ended outputs shorted to GND
15	Output Short Circuit Current Differential	I_{SD}	-24		24	mA	Complementary outputs shorted
16	Output enable time	t_{EN}			3	cycles	
17	Output disable time	t_{DIS}			3	cycles	
18	Additive RMS jitter in 1MHz to 20MHz band	T_{L1M_20M}		107	140	fs	Input clock: 100 MHz
				62	77	fs	Input clock: 156.25MHz
				20	31	fs	Input clock: 625 MHz
19	Additive RMS jitter in 12kHz to 20MHz band	T_{L12K_20M}		111	146	fs	Input clock: 100 MHz
				66	83	fs	Input clock: 156.25MHz
				24	36	fs	Input clock: 625 MHz
20	Noise floor	N_F		-158	-156	dBc/Hz	Input clock: 100 MHz
				-159	-155	dBc/Hz	Input clock: 156.25 MHz
				-155	-151	dBc/Hz	Input clock: 625 MHz

* Values are over Recommended Operating Conditions

**Output differential swing is calculated as $V_{SW} = V_{OH} - V_{OL}$. It should not be confused with $V_{SW} = 2 * (V_{OH} - V_{OL})$ used in some datasheets. Please refer to Figure 42.

Table 18 HCSL Outputs for VDDO = 3.3V*

	Characteristics	Sym.	Min.	Typ.	Max.	Units	Notes
1	Output high voltage	V_{HCSL_OH}	0.6	0.85	1.1	V	DC Measurement
2	Output low voltage	V_{HCSL_OL}	-0.05	0	0.05	V	DC Measurement
3	Output differential swing**	V_{HCSL_SW}	0.6	0.85	1.1	V	DC Measurement
4	Variation of V_{HCSL_SW} for complementary output states	ΔV_{HCSL_SW}	0	0.003	0.05	V	
5	Common mode output	V_{CM}	0.28	0.43	0.55	V	
6	Variation of V_{CM} for complementary output states	ΔV_{CM}	0	0.002	0.05	V	
7	Absolute Crossing Voltage	V_{CROSS}	0.320	0.384	0.447	V	
8	Total Variation of V_{CROSS}	ΔV_{CROSS}			0.127	V	
9	Output frequency	F_{MAX}	0		400	MHz	
10	Rise or fall time (20% to 80%)	t_r, t_f		143	309	ps	
11	Output to output skew	t_{OOSK}			21	ps	
12	Device to device output skew	t_{DOOSK}			129	ps	
13	Input to output delay	t_{IOD}	0.73	0.90	1.08	ns	
14	Output enable time	t_{EN}			3	cycles	
15	Output disable time	t_{DIS}			3	cycles	
16	Additive Jitter as per PCIe 3.0 (PLL_BW = 2 to 5MHz, CDR = 10MHz)	$T_{JPCIe_3.0}$		20	40	fs	Input clock: 100MHz
17	Additive RMS jitter in 1MHz to 20MHz band	T_{L1M_20M}		73	104	fs	Input clock: 100 MHz
				53	69	fs	Input clock: 156.25MHz
18	Additive RMS jitter in 12kHz to 20MHz band	T_{L12K_20M}		77	112	fs	Input clock: 100 MHz
				64	100	fs	Input clock: 156.25MHz
19	Noise floor	N_F		-161	-159	dBc/Hz	Input clock: 100 MHz
				-159	-155	dBc/Hz	Input clock: 156.25 MHz

* Values are over Recommended Operating Conditions

**Output differential swing is calculated as $V_{SW} = V_{OH} - V_{OL}$. It should not be confused with $V_{SW} = 2 * (V_{OH} - V_{OL})$ used in some datasheets. Please refer to Figure 42.

Table 19 HCSL Outputs for VDDO = 2.5V*

	Characteristics	Sym.	Min.	Typ.	Max.	Units	Notes
1	Output high voltage	$V_{\text{HCSL_OH}}$	0.6	0.83	1.1	V	DC Measurement
2	Output low voltage	$V_{\text{HCSL_OL}}$	-0.05	0	0.05	V	DC Measurement
3	Output differential swing**	$V_{\text{HCSL_SW}}$	0.5	0.83	1.1	V	DC Measurement
4	Variation of $V_{\text{HCSL_SW}}$ for complementary output states	$\Delta V_{\text{HCSL_SW}}$	0	0.003	0.05	V	
5	Common mode output	V_{CM}	0.28	0.42	0.55	V	
6	Variation of V_{CM} for complementary output states	ΔV_{CM}	0	0.002	0.05	V	
7	Absolute Crossing Voltage	V_{CROSS}	0.260	0.316	0.372	V	
8	Total Variation of V_{CROSS}	ΔV_{CROSS}			0.108	V	
9	Output frequency	F_{MAX}	0		400	MHz	
10	Rise or fall time (20% to 80%)	t_r, t_f		125	162	ps	
11	Output to output skew	t_{OOSK}			21	ps	
12	Device to device output skew	t_{DOOSK}			129	ps	
13	Input to output delay	t_{IOD}	0.76	0.92	1.10	ns	
14	Output enable time	t_{EN}			3	cycles	
15	Output disable time	t_{DIS}			3	cycles	
16	Additive Jitter as per PCIe 3.0 (PLL_BW = 2 to 5MHz, CDR = 10MHz)	$T_{\text{JPCIe}_3.0}$		20	40	fs	Input clock: 100MHz
17	Additive RMS jitter in 1MHz to 20MHz band	$T_{\text{L}1\text{M}_20\text{M}}$		68	95	fs	Input clock: 100 MHz
				52	66	fs	Input clock: 156.25MHz
18	Additive RMS jitter in 12kHz to 20MHz band	$T_{\text{L}12\text{k}_20\text{M}}$		72	102	fs	Input clock: 100 MHz
				56	71	fs	Input clock: 156.25MHz
19	Noise floor	N_{F}		-161	-158	dBc/Hz	Input clock: 100 MHz
				-160	-153	dBc/Hz	Input clock: 156.25 MHz

* Values are over Recommended Operating Conditions

**Output differential swing is calculated as $V_{\text{SW}} = V_{\text{OH}} - V_{\text{OL}}$. It should not be confused with $V_{\text{SW}} = 2 * (V_{\text{OH}} - V_{\text{OL}})$ used in some datasheets. Please refer to Figure 42.

Table 20 LVCMOS Output Phase Noise with 25 MHz XTAL*

	Characteristics	Min.	Typ.	Max.	Units	Notes
1	Jitter RMS in 12kHz to 5MHz band		103		fs	VDD = 3.3V, VDDO = 3.3V
			117		fs	VDD = 2.5V; VDDO = 2.5V
2	Noise floor		-75		dBc/Hz	@10Hz, VDD = 3.3V, VDDO = 3.3V
			-107		dBc/Hz	@100Hz, VDD = 3.3V, VDDO = 3.3V
			-132		dBc/Hz	@1kHz, VDD = 3.3V, VDDO = 3.3V
			-150		dBc/Hz	@10kHz, VDD = 3.3V, VDDO = 3.3V
			-162		dBc/Hz	@100kHz, VDD = 3.3V, VDDO = 3.3V
			-166		dBc/Hz	@1MHz, VDD = 3.3V, VDDO = 3.3V
			-166		dBc/Hz	@5MHz, VDD = 3.3V, VDDO = 3.3V
			-70		dBc/Hz	@10Hz, VDD = 2.5V; VDDO = 2.5V
			-102		dBc/Hz	@100Hz, VDD = 2.5V; VDDO = 2.5V
			-130		dBc/Hz	@1kHz, VDD = 2.5V; VDDO = 2.5V
			-149		dBc/Hz	@10kHz, VDD = 2.5V; VDDO = 2.5V
			-161		dBc/Hz	@100kHz, VDD = 2.5V; VDDO = 2.5V
	-165		dBc/Hz	@1MHz, VDD = 2.5V; VDDO = 2.5V		
	-165		dBc/Hz	@5MHz, VDD = 2.5V; VDDO = 2.5V		

* Values are over Recommended Operating Conditions

Table 21 LVPECL Output Phase Noise with 25 MHz XTAL*

	Characteristics	Min.	Typ.	Max.	Units	Notes
1	Jitter RMS in 12kHz to 5MHz band		265		fs	VDD = 3.3V, VDDO = 3.3V
			213		fs	VDD = 2.5V; VDDO = 2.5V
2	Noise floor		-75		dBc/Hz	@10Hz, VDD = 3.3V, VDDO = 3.3V
			-107		dBc/Hz	@100Hz, VDD = 3.3V, VDDO = 3.3V
			-133		dBc/Hz	@1kHz, VDD = 3.3V, VDDO = 3.3V
			-152		dBc/Hz	@10kHz, VDD = 3.3V, VDDO = 3.3V
			-157		dBc/Hz	@100kHz, VDD = 3.3V, VDDO = 3.3V
			-158		dBc/Hz	@1MHz, VDD = 3.3V, VDDO = 3.3V
			-157		dBc/Hz	@5MHz, VDD = 3.3V, VDDO = 3.3V
			-71		dBc/Hz	@10Hz, VDD = 2.5V; VDDO = 2.5V
			-103		dBc/Hz	@100Hz, VDD = 2.5V; VDDO = 2.5V
			-130		dBc/Hz	@1kHz, VDD = 2.5V; VDDO = 2.5V
			-151		dBc/Hz	@10kHz, VDD = 2.5V; VDDO = 2.5V
			-158		dBc/Hz	@100kHz, VDD = 2.5V; VDDO = 2.5V
	-160		dBc/Hz	@1MHz, VDD = 2.5V; VDDO = 2.5V		
	-159		dBc/Hz	@5MHz, VDD = 2.5V; VDDO = 2.5V		

* Values are over Recommended Operating Conditions

Table 22 LVDS Output Phase Noise with 25 MHz XTAL

	Characteristics	Min.	Typ.	Max.	Units	Notes
1	Jitter RMS in 12kHz to 5MHz band		178		fs	VDD = 3.3V, VDDO = 3.3V
			190		fs	VDD = 2.5V; VDDO = 2.5V
2	Noise floor		-75		dBc/Hz	@10Hz, VDD = 3.3V, VDDO = 3.3V
			-107		dBc/Hz	@100Hz, VDD = 3.3V, VDDO = 3.3V
			-133		dBc/Hz	@1kHz, VDD = 3.3V, VDDO = 3.3V
			-154		dBc/Hz	@10kHz, VDD = 3.3V, VDDO = 3.3V
			-161		dBc/Hz	@100kHz, VDD = 3.3V, VDDO = 3.3V
			-161		dBc/Hz	@1MHz, VDD = 3.3V, VDDO = 3.3V
			-160		dBc/Hz	@5MHz, VDD = 3.3V, VDDO = 3.3V
			-68		dBc/Hz	@10Hz, VDD = 2.5V; VDDO = 2.5V
			-103		dBc/Hz	@100Hz, VDD = 2.5V; VDDO = 2.5V
			-130		dBc/Hz	@1kHz, VDD = 2.5V; VDDO = 2.5V
			-152		dBc/Hz	@10kHz, VDD = 2.5V; VDDO = 2.5V
			-161		dBc/Hz	@100kHz, VDD = 2.5V; VDDO = 2.5V
	-160		dBc/Hz	@1MHz, VDD = 2.5V; VDDO = 2.5V		
	-159		dBc/Hz	@5MHz, VDD = 2.5V; VDDO = 2.5V		

* Values are over Recommended Operating Conditions

Table 23 HCSL Output Phase Noise with 25 MHz XTAL

	Characteristics	Min.	Typ.	Max.	Units	Notes
1	Jitter RMS in 12kHz to 20MHz band		269		fs	VDD = 3.3V, VDDO = 3.3V
			228		fs	VDD = 2.5V; VDDO = 2.5V
2	Noise floor		-76		dBc/Hz	@10Hz, VDD = 3.3V, VDDO = 3.3V
			-107		dBc/Hz	@100Hz, VDD = 3.3V, VDDO = 3.3V
			-133		dBc/Hz	@1kHz, VDD = 3.3V, VDDO = 3.3V
			-152		dBc/Hz	@10kHz, VDD = 3.3V, VDDO = 3.3V
			-157		dBc/Hz	@100kHz, VDD = 3.3V, VDDO = 3.3V
			-157		dBc/Hz	@1MHz, VDD = 3.3V, VDDO = 3.3V
			-157		dBc/Hz	@5MHz, VDD = 3.3V, VDDO = 3.3V
			-73		dBc/Hz	@10Hz, VDD = 2.5V; VDDO = 2.5V
			-105		dBc/Hz	@100Hz, VDD = 2.5V; VDDO = 2.5V
			-131		dBc/Hz	@1kHz, VDD = 2.5V; VDDO = 2.5V
			-151		dBc/Hz	@10kHz, VDD = 2.5V; VDDO = 2.5V
			-158		dBc/Hz	@100kHz, VDD = 2.5V; VDDO = 2.5V
	-159		dBc/Hz	@1MHz, VDD = 2.5V; VDDO = 2.5V		
	-159		dBc/Hz	@5MHz, VDD = 2.5V; VDDO = 2.5V		

* Values are over Recommended Operating Conditions

Table 24 LVCMOS Output Phase Noise with 125 MHz XTAL*

	Characteristics	Min.	Typ.	Max.	Units	Notes
1	Jitter RMS in 12kHz to 20MHz band		92		fs	VDD = 3.3V, VDDO = 3.3V
			105		fs	VDD = 2.5V; VDDO = 2.5V
2	Noise floor		-58		dBc/Hz	@10Hz, VDD = 3.3V, VDDO = 3.3V
			-90		dBc/Hz	@100Hz, VDD = 3.3V, VDDO = 3.3V
			-118		dBc/Hz	@1kHz, VDD = 3.3V, VDDO = 3.3V
			-136		dBc/Hz	@10kHz, VDD = 3.3V, VDDO = 3.3V
			-150		dBc/Hz	@100kHz, VDD = 3.3V, VDDO = 3.3V
			-158		dBc/Hz	@1MHz, VDD = 3.3V, VDDO = 3.3V
			-159		dBc/Hz	@10MHz, VDD = 3.3V, VDDO = 3.3V
			-53		dBc/Hz	@10Hz, VDD = 2.5V; VDDO = 2.5V
			-86		dBc/Hz	@100Hz, VDD = 2.5V; VDDO = 2.5V
			-113		dBc/Hz	@1kHz, VDD = 2.5V; VDDO = 2.5V
			-134		dBc/Hz	@10kHz, VDD = 2.5V; VDDO = 2.5V
			-148		dBc/Hz	@100kHz, VDD = 2.5V; VDDO = 2.5V
			-157		dBc/Hz	@1MHz, VDD = 2.5V; VDDO = 2.5V
			-158		dBc/Hz	@10MHz, VDD = 2.5V; VDDO = 2.5V

* Values are over Recommended Operating Conditions

Table 25 LVPECL Output Phase Noise with 125 MHz XTAL*

	Characteristics	Min.	Typ.	Max.	Units	Notes
1	Jitter RMS in 12kHz to 20MHz band		76		fs	VDD = 3.3V, VDDO = 3.3V
			86		fs	VDD = 2.5V; VDDO = 2.5V
2	Noise floor		-58		dBc/Hz	@10Hz, VDD = 3.3V, VDDO = 3.3V
			-90		dBc/Hz	@100Hz, VDD = 3.3V, VDDO = 3.3V
			-118		dBc/Hz	@1kHz, VDD = 3.3V, VDDO = 3.3V
			-140		dBc/Hz	@10kHz, VDD = 3.3V, VDDO = 3.3V
			-154		dBc/Hz	@100kHz, VDD = 3.3V, VDDO = 3.3V
			-159		dBc/Hz	@1MHz, VDD = 3.3V, VDDO = 3.3V
			-161		dBc/Hz	@10MHz, VDD = 3.3V, VDDO = 3.3V
			-54		dBc/Hz	@10Hz, VDD = 2.5V; VDDO = 2.5V
			-86		dBc/Hz	@100Hz, VDD = 2.5V; VDDO = 2.5V
			-114		dBc/Hz	@1kHz, VDD = 2.5V; VDDO = 2.5V
			-137		dBc/Hz	@10kHz, VDD = 2.5V; VDDO = 2.5V
			-152		dBc/Hz	@100kHz, VDD = 2.5V; VDDO = 2.5V
			-158		dBc/Hz	@1MHz, VDD = 2.5V; VDDO = 2.5V
			-160		dBc/Hz	@10MHz, VDD = 2.5V; VDDO = 2.5V

* Values are over Recommended Operating Conditions

Table 26 LVDS Output Phase Noise with 125 MHz XTAL

	Characteristics	Min.	Typ.	Max.	Units	Notes
1	Jitter RMS in 12kHz to 20MHz band		98		fs	VDD = 3.3V, VDDO = 3.3V
			100		fs	VDD = 2.5V; VDDO = 2.5V
2	Noise floor		-57		dBc/Hz	@10Hz, VDD = 3.3V, VDDO = 3.3V
			-90		dBc/Hz	@100Hz, VDD = 3.3V, VDDO = 3.3V
			-118		dBc/Hz	@1kHz, VDD = 3.3V, VDDO = 3.3V
			-140		dBc/Hz	@10kHz, VDD = 3.3V, VDDO = 3.3V
			-152		dBc/Hz	@100kHz, VDD = 3.3V, VDDO = 3.3V
			-157		dBc/Hz	@1MHz, VDD = 3.3V, VDDO = 3.3V
			-158		dBc/Hz	@10MHz, VDD = 3.3V, VDDO = 3.3V
			-54		dBc/Hz	@10Hz, VDD = 2.5V; VDDO = 2.5V
			-86		dBc/Hz	@100Hz, VDD = 2.5V; VDDO = 2.5V
			-114		dBc/Hz	@1kHz, VDD = 2.5V; VDDO = 2.5V
			-137		dBc/Hz	@10kHz, VDD = 2.5V; VDDO = 2.5V
			-153		dBc/Hz	@100kHz, VDD = 2.5V; VDDO = 2.5V
	-157		dBc/Hz	@1MHz, VDD = 2.5V; VDDO = 2.5V		
	-158		dBc/Hz	@10MHz, VDD = 2.5V; VDDO = 2.5V		

* Values are over Recommended Operating Conditions

Table 27 HCSL Output Phase Noise with 125 MHz XTAL

	Characteristics	Min.	Typ.	Max.	Units	Notes
1	Jitter RMS in 12kHz to 20MHz band		83		fs	VDD = 3.3V, VDDO = 3.3V
			85		fs	VDD = 2.5V; VDDO = 2.5V
2	Noise floor		-58		dBc/Hz	@10Hz, VDD = 3.3V, VDDO = 3.3V
			-90		dBc/Hz	@100Hz, VDD = 3.3V, VDDO = 3.3V
			-118		dBc/Hz	@1kHz, VDD = 3.3V, VDDO = 3.3V
			-140		dBc/Hz	@10kHz, VDD = 3.3V, VDDO = 3.3V
			-152		dBc/Hz	@100kHz, VDD = 3.3V, VDDO = 3.3V
			-158		dBc/Hz	@1MHz, VDD = 3.3V, VDDO = 3.3V
			-160		dBc/Hz	@10MHz, VDD = 3.3V, VDDO = 3.3V
			-54		dBc/Hz	@10Hz, VDD = 2.5V; VDDO = 2.5V
			-86		dBc/Hz	@100Hz, VDD = 2.5V; VDDO = 2.5V
			-114		dBc/Hz	@1kHz, VDD = 2.5V; VDDO = 2.5V
			-137		dBc/Hz	@10kHz, VDD = 2.5V; VDDO = 2.5V
			-153		dBc/Hz	@100kHz, VDD = 2.5V; VDDO = 2.5V
	-158		dBc/Hz	@1MHz, VDD = 2.5V; VDDO = 2.5V		
	-159		dBc/Hz	@10MHz, VDD = 2.5V; VDDO = 2.5V		

* Values are over Recommended Operating Conditions

Table 28 LVCMOS Output Phase Noise with 156.25 MHz XTAL*

	Characteristics	Min.	Typ.	Max.	Units	Notes
1	Jitter RMS in 12kHz to 20MHz band		79		fs	VDD = 3.3V, VDDO = 3.3V
			88		fs	VDD = 2.5V; VDDO = 2.5V
2	Noise floor		-53		dBc/Hz	@10Hz, VDD = 3.3V, VDDO = 3.3V
			-81		dBc/Hz	@100Hz, VDD = 3.3V, VDDO = 3.3V
			-111		dBc/Hz	@1kHz, VDD = 3.3V, VDDO = 3.3V
			-135		dBc/Hz	@10kHz, VDD = 3.3V, VDDO = 3.3V
			-149		dBc/Hz	@100kHz, VDD = 3.3V, VDDO = 3.3V
			-157		dBc/Hz	@1MHz, VDD = 3.3V, VDDO = 3.3V
			-159		dBc/Hz	@10MHz, VDD = 3.3V, VDDO = 3.3V
			-53		dBc/Hz	@10Hz, VDD = 2.5V; VDDO = 2.5V
			-82		dBc/Hz	@100Hz, VDD = 2.5V; VDDO = 2.5V
			-113		dBc/Hz	@1kHz, VDD = 2.5V; VDDO = 2.5V
			-135		dBc/Hz	@10kHz, VDD = 2.5V; VDDO = 2.5V
			-148		dBc/Hz	@100kHz, VDD = 2.5V; VDDO = 2.5V
			-156		dBc/Hz	@1MHz, VDD = 2.5V; VDDO = 2.5V
			-158		dBc/Hz	@10MHz, VDD = 2.5V; VDDO = 2.5V

* Values are over Recommended Operating Conditions

Table 29 LVPECL Output Phase Noise with 156.25 MHz XTAL*

	Characteristics	Min.	Typ.	Max.	Units	Notes
1	Jitter RMS in 12kHz to 20MHz band		61		fs	VDD = 3.3V, VDDO = 3.3V
			68		fs	VDD = 2.5V; VDDO = 2.5V
2	Noise floor		-52		dBc/Hz	@10Hz, VDD = 3.3V, VDDO = 3.3V
			-80		dBc/Hz	@100Hz, VDD = 3.3V, VDDO = 3.3V
			-111		dBc/Hz	@1kHz, VDD = 3.3V, VDDO = 3.3V
			-140		dBc/Hz	@10kHz, VDD = 3.3V, VDDO = 3.3V
			-153		dBc/Hz	@100kHz, VDD = 3.3V, VDDO = 3.3V
			-159		dBc/Hz	@1MHz, VDD = 3.3V, VDDO = 3.3V
			-161		dBc/Hz	@10MHz, VDD = 3.3V, VDDO = 3.3V
			-53		dBc/Hz	@10Hz, VDD = 2.5V; VDDO = 2.5V
			-81		dBc/Hz	@100Hz, VDD = 2.5V; VDDO = 2.5V
			-114		dBc/Hz	@1kHz, VDD = 2.5V; VDDO = 2.5V
			-140		dBc/Hz	@10kHz, VDD = 2.5V; VDDO = 2.5V
			-151		dBc/Hz	@100kHz, VDD = 2.5V; VDDO = 2.5V
			-158		dBc/Hz	@1MHz, VDD = 2.5V; VDDO = 2.5V
			-160		dBc/Hz	@10MHz, VDD = 2.5V; VDDO = 2.5V

* Values are over Recommended Operating Conditions

Table 30 LVDS Output Phase Noise with 156.25 MHz XTAL

	Characteristics	Min.	Typ.	Max.	Units	Notes
1	Jitter RMS in 12kHz to 20MHz band		79		fs	VDD = 3.3V, VDDO = 3.3V
			76		fs	VDD = 2.5V; VDDO = 2.5V
2	Noise floor		-52		dBc/Hz	@10Hz, VDD = 3.3V, VDDO = 3.3V
			-81		dBc/Hz	@100Hz, VDD = 3.3V, VDDO = 3.3V
			-111		dBc/Hz	@1kHz, VDD = 3.3V, VDDO = 3.3V
			-138		dBc/Hz	@10kHz, VDD = 3.3V, VDDO = 3.3V
			-148		dBc/Hz	@100kHz, VDD = 3.3V, VDDO = 3.3V
			-157		dBc/Hz	@1MHz, VDD = 3.3V, VDDO = 3.3V
			-159		dBc/Hz	@10MHz, VDD = 3.3V, VDDO = 3.3V
			-52		dBc/Hz	@10Hz, VDD = 2.5V; VDDO = 2.5V
			-82		dBc/Hz	@100Hz, VDD = 2.5V; VDDO = 2.5V
			-113		dBc/Hz	@1kHz, VDD = 2.5V; VDDO = 2.5V
			-140		dBc/Hz	@10kHz, VDD = 2.5V; VDDO = 2.5V
			-151		dBc/Hz	@100kHz, VDD = 2.5V; VDDO = 2.5V
			-157		dBc/Hz	@1MHz, VDD = 2.5V; VDDO = 2.5V
			-159		dBc/Hz	@10MHz, VDD = 2.5V; VDDO = 2.5V

* Values are over Recommended Operating Conditions

Table 31 HCSL Output Phase Noise with 156.25 MHz XTAL

	Characteristics	Min.	Typ.	Max.	Units	Notes
1	Jitter RMS in 12kHz to 20MHz band		72		fs	VDD = 3.3V, VDDO = 3.3V
			72		fs	VDD = 2.5V; VDDO = 2.5V
2	Noise floor		-53		dBc/Hz	@10Hz, VDD = 3.3V, VDDO = 3.3V
			-86		dBc/Hz	@100Hz, VDD = 3.3V, VDDO = 3.3V
			-114		dBc/Hz	@1kHz, VDD = 3.3V, VDDO = 3.3V
			-139		dBc/Hz	@10kHz, VDD = 3.3V, VDDO = 3.3V
			-148		dBc/Hz	@100kHz, VDD = 3.3V, VDDO = 3.3V
			-157		dBc/Hz	@1MHz, VDD = 3.3V, VDDO = 3.3V
			-160		dBc/Hz	@10MHz, VDD = 3.3V, VDDO = 3.3V
			-53		dBc/Hz	@10Hz, VDD = 2.5V; VDDO = 2.5V
			-86		dBc/Hz	@100Hz, VDD = 2.5V; VDDO = 2.5V
			-115		dBc/Hz	@1kHz, VDD = 2.5V; VDDO = 2.5V
			-140		dBc/Hz	@10kHz, VDD = 2.5V; VDDO = 2.5V
			-151		dBc/Hz	@100kHz, VDD = 2.5V; VDDO = 2.5V
			-157		dBc/Hz	@1MHz, VDD = 2.5V; VDDO = 2.5V
			-160		dBc/Hz	@10MHz, VDD = 2.5V; VDDO = 2.5V

* Values are over Recommended Operating Conditions

Table 32 AC Electrical Characteristics* - SPI (Serial Peripheral Interface) Timing

	Characteristics	Sym.	Min.	Typ.	Max.	Units	Notes
1	sck period	tcyc	124			ns	See Figure 43& Figure 44
2	sck pulse width low	tclkL	62			ns	
3	sck pulse width high	tclkH	62			ns	
4	si setup (write) from sck rising edge	trxs	10			ns	
5	si hold (write) from sck falling edge	trxh	10			ns	
6	so delay (read) from sck falling edge	txd			25	ns	
7	cs_b to output high impedance	tohz			60	ns	
8	cs_b setup from sck falling edge (LSB first)	tcssi	20			ns	See Figure 43
9	cs_b hold from sck falling edge (LSB first)	tcshi	10			ns	
10	cs_b setup from sck falling edge (MSB first)	tcsmm	20			ns	See Figure 44
11	cs_b hold from sck falling edge (MSB first)	tcshm	10			ns	

* Values are over Recommended Operating Conditions
 * For LSB first mode timing diagram, refer to Figure 43
 * For MSB first mode timing diagram, refer to Figure 44
 * Values shown are proposed for the data sheet, these values are to be confirmed

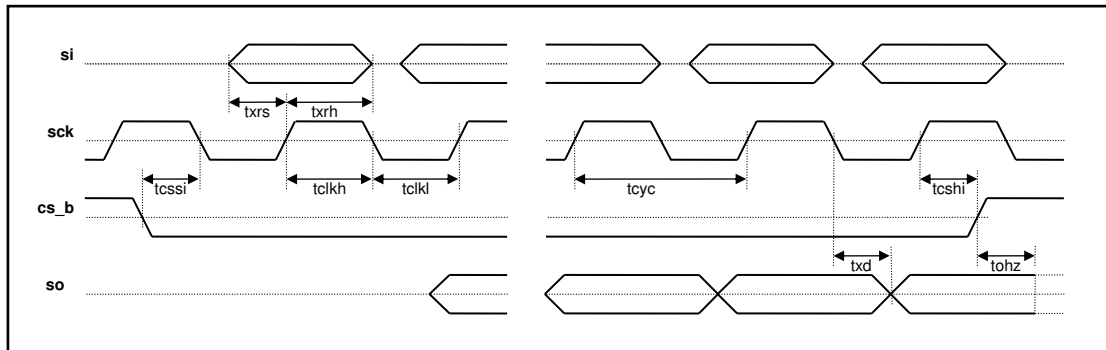

Figure 43. SPI (Serial Peripheral Interface) Timing - LSB First Mode

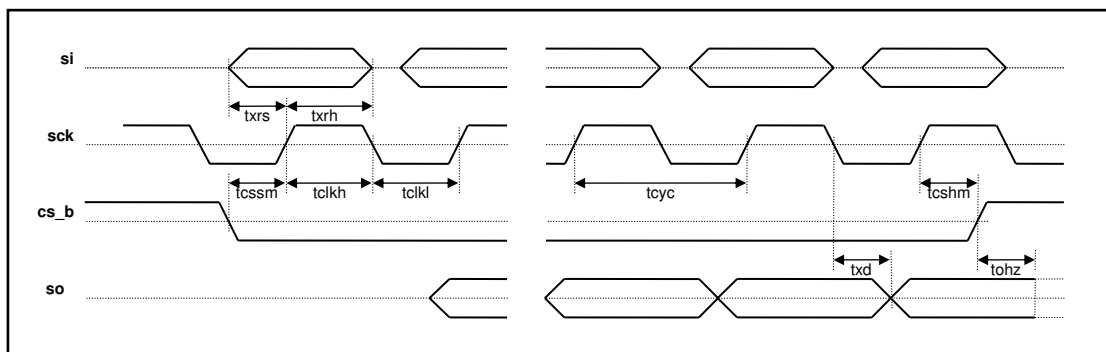

Figure 44. SPI (Serial Peripheral Interface) Timing - MSB First Mode

Table 33 6x6mm QFN Package Thermal Properties

Parameter	Symbol	Condition	Value	Units
Maximum Ambient Temperature	T_A		85	°C
Maximum Junction Temperature	T_{JMAX}		125	°C
Junction to Ambient Thermal Resistance ⁽¹⁾ (Note 1)	θ_{JA}	still air	22.2	°C/W
		1m/s airflow	17.6	
		2.5m/s airflow	15.8	
Junction to Board Thermal Resistance	θ_{JB}		7.2	°C/W
Junction to Case Thermal Resistance	θ_{JC}		14.3	°C/W
Junction to Pad Thermal Resistance ⁽²⁾	θ_{JP}	Still air	3.9	°C/W
Junction to Top-Center Thermal Characterization Parameter	Ψ_{JT}	Still air	0.2	°C/W

(1) Theta-JA (θ_{JA}) is the thermal resistance from junction to ambient when the package is mounted on an 4-layer JEDEC standard test board and dissipating maximum power

(2) Theta-JP (θ_{JP}) is the thermal resistance from junction to the center exposed pad on the bottom of the package)

Change History

June 2017 was the first release of the document.

July 2017 release changes:

- Modified power calculation in the Power Consumption section.

August 2017 release changes:

- Modified "Input driven by HCSL output" figure.
- Modified additive jitter for 156.25MHz input clock.
- Added Figure 41 and Figure 42.

October 2018 release changes:

- Added note in pinout to tie XIN pin when crystal circuit is not used
- Removed Figures 13, 15 and 16 due to inaccuracy
- Fixed typo in Table 3

Package Outline

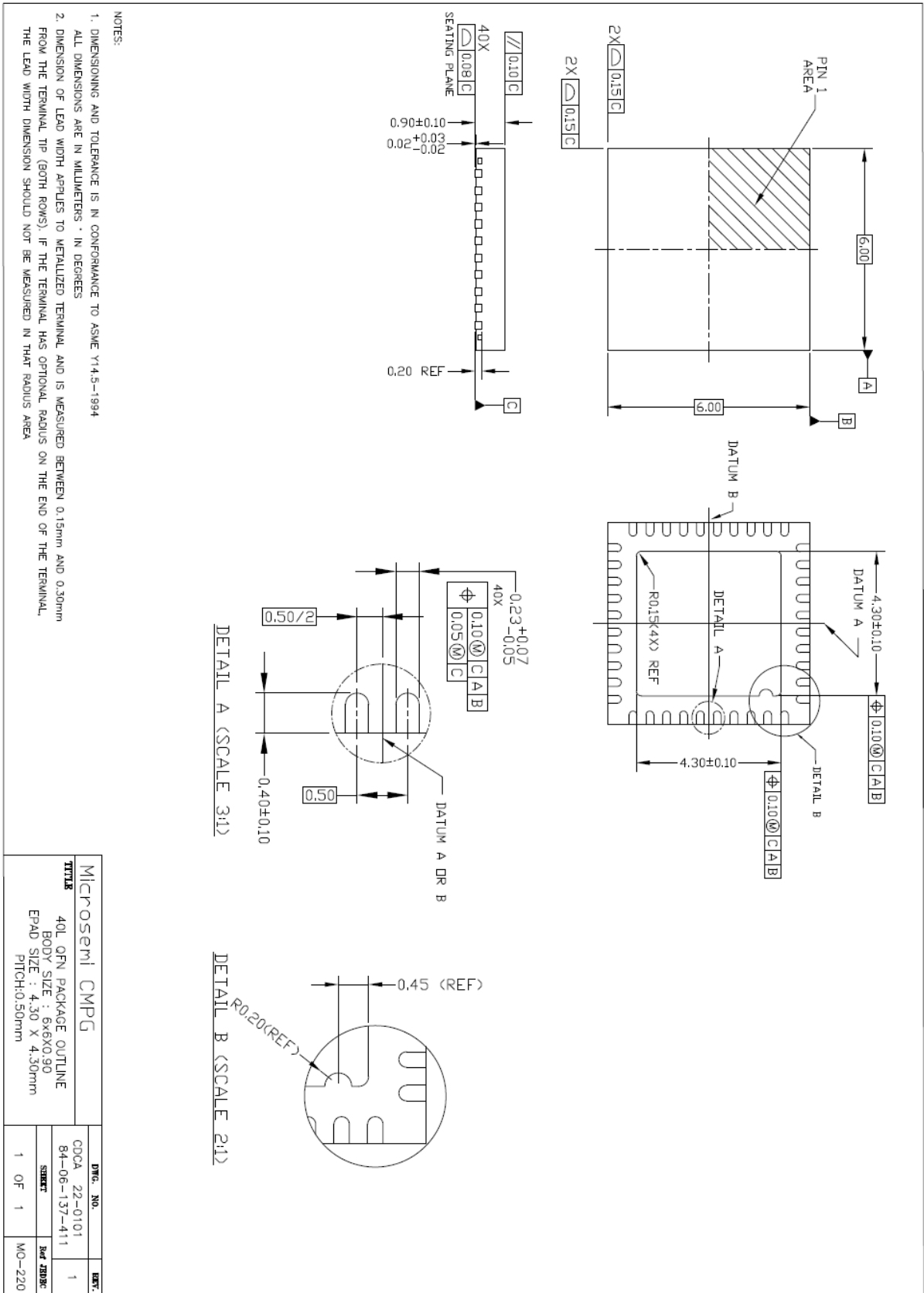



Microsemi Corporate Headquarters
One Enterprise, Aliso Viejo,
CA 92656 USA

Within the USA: +1 (800) 713-4113
Outside the USA: +1 (949) 380-6100
Sales: +1 (949) 380-6136
Fax: +1 (949) 215-4996

E-mail: sales.support@microsemi.com

© 2017 Microsemi Corporation. All rights reserved. Microsemi and the Microsemi logo are trademarks of Microsemi Corporation. All other trademarks and service marks are the property of their respective owners.

Microsemi Corporation, a wholly owned subsidiary Microchip Technology Inc. (Nasdaq: MCHP), offers a comprehensive portfolio of semiconductor and system solutions for communications, defense & security, aerospace and industrial markets. Products include high-performance and radiation-hardened analog mixed-signal integrated circuits, FPGAs, SoCs and ASICs; power management products; timing and synchronization devices and precise time solutions, setting the world's standard for time; voice processing devices; RF solutions; discrete components; enterprise storage and communication solutions, security technologies and scalable anti-tamper products; Ethernet solutions; Power-over-Ethernet ICs and midspans; as well as custom design capabilities and services. Microsemi is headquartered in Aliso Viejo, California. Learn more at www.microsemi.com.

Microsemi makes no warranty, representation, or guarantee regarding the information contained herein or the suitability of its products and services for any particular purpose, nor does Microsemi assume any liability whatsoever arising out of the application or use of any product or circuit. The products sold hereunder and any other products sold by Microsemi have been subject to limited testing and should not be used in conjunction with mission-critical equipment or applications. Any performance specifications are believed to be reliable but are not verified, and Buyer must conduct and complete all performance and other testing of the products, alone and together with, or installed in, any end-products. Buyer shall not rely on any data and performance specifications or parameters provided by Microsemi. It is the Buyer's responsibility to independently determine suitability of any products and to test and verify the same. The information provided by Microsemi hereunder is provided "as is, where is" and with all faults, and the entire risk associated with such information is entirely with the Buyer. Microsemi does not grant, explicitly or implicitly, to any party any patent rights, licenses, or any other IP rights, whether with regard to such information itself or anything described by such information. Information provided in this document is proprietary to Microsemi, and Microsemi reserves the right to make any changes to the information in this document or to any products and services at any time without notice.