

Summary

The DIODES™ ZABG6003 is an advanced GaAs and HEMT FETs bias controller designed to operate from minimal supply rails and intended primarily for satellite Low Noise Blocks (LNBs). With the addition of one capacitor and a resistor, the ZABG6003 provides drain voltage and current control for up to 6 external grounded source FETs. Generating the regulated negative rail required for FET gate biasing whilst operating from a single supply of 2.1V to 5V. The -2V negative bias can also be used to supply other external circuits.

Setting drain currents on the ZABG6003 only requires one resistor which controls the drain current of the first stage FETS (D1 and D4). The drain current is set internally to 10mA for the remaining 4 FETs for the second and third stages. This allows the operating current of input FETs to be adjusted to minimize noise, whilst the following FET stages are fixed to minimize the number of external components used.

Features

- Provides Bias for up to 6 GaAs and HEMT FETs
 - 2 × Amplifier FET Drain Current Programmable (4mA to 15mA)
 - 4 × Amplifier FET Drain Current Internally Fixed to 10mA
- Operating Range of 2.1V to 5V
- Ultra-Low Operating Current of 1.1mA
- Dynamic FET Protection
- Regulated Negative Rail Generator Requires only 1 External Capacitor
- Expanded Temperature Range of -40°C to +105°C
- U-QFN3030-16 (Type B) Surface Mount Package
- Low External Component Count
- **Totally Lead-Free & Fully RoHS Compliant (Notes 1 & 2)**
- **Halogen and Antimony Free. "Green" Device (Note 3)**
- **For automotive applications requiring specific change control (i.e. parts qualified to AEC-Q100/101/104/200, PPAP capable, and manufactured in IATF 16949 certified facilities), please [contact us](#) or your local Diodes representative. <https://www.diodes.com/quality/product-definitions/>**

Applications

- Low power LNB's
- Digital LNB's
- IP LNB's
- Twin and quad LNB's
- General purpose LNA bias

- Notes:
1. No purposely added lead. Fully EU Directive 2002/95/EC (RoHS), 2011/65/EU (RoHS 2) & 2015/863/EU (RoHS 3) compliant.
 2. See <https://www.diodes.com/quality/lead-free/> for more information about Diodes Incorporated's definitions of Halogen- and Antimony-free, "Green" and Lead-free.
 3. Halogen- and Antimony-free "Green" products are defined as those which contain <900ppm bromine, <900ppm chlorine (<1500ppm total Br + Cl) and <1000ppm antimony compounds.

Twin LNB System Diagrams

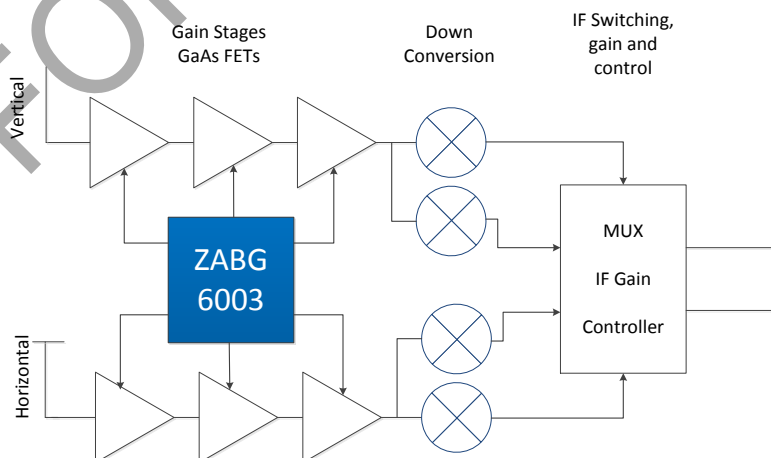

Device Description

The ZABG series of devices are designed to meet the bias requirements of GaAs and HEMT FETs commonly used in satellite receiver LNBS with a minimum of external components whilst operating from a minimal voltage supply and using minimal current.

The ZABG6003 has six FET bias stages. To optimize the system for noise and gain the drain current for two of the six stages can be programmed over the range of 4mA to 15mA. Programming the drain current of FETS D1 and D4 is achieved by a resistor connected to the R_{CAL1} pin. The Drain current of the remaining four FETS D2, D3, D5 and D6 are internally set to 10mA.

Drain voltages of amplifier stages are set at 2.0V and are current limited to approximately current set by their associated R_{CAL} resistors.

Depletion mode FETs require a negative voltage bias supply when operated in grounded source circuits. The ZABG6003 includes an integrated switched capacitor DC-DC converter generating a regulated output of -2V to allow single supply operation. The ZABG6003 has been designed to be used with supply rails of 2.1V to 5.0V and the V_{DD} range has been extended to 5.5V to allow for 10% supply variation.

It is possible to use less than the full complement of FET bias controls, unused drain and gate connections can be left open circuit without affecting operation of the remaining bias circuits.

To protect the external FETs the circuits have been designed to ensure that, under any conditions including power up/down transients, the gate drive from the bias circuits cannot exceed -2.5V. Additionally each stage has its own individual current limiter. Furthermore if the negative rail experiences a fault condition, such as overload or short circuit, the drain supply to the FETs will be limited, avoiding excessive current flow.

The ZABG6003 is available in the U-QFN3030-16 (Type B) package.

Device operating temperature is -40°C to +105°C to suit a wide range of environmental conditions.

Pin Assignments and Descriptions

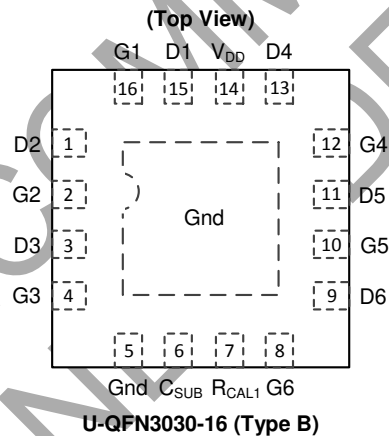

Pin Number	Pin Name	Description
1	D2	Drain GaAs FET 2
2	G2	Gate GaAs FET 2
3	D3	Drain GaAs FET 3
4	G3	Gate GaAs FET 3
5	Gnd	Ground
6	C _{SUB}	Negative rail reservoir capacitor
7	R _{CAL1}	Drain current setting for D1 and D4
8	G6	Gate GaAs FET 6
9	D6	Drain GaAs FET 6
10	G5	Gate GaAs FET 5
11	D5	Drain GaAs FET 5
12	G4	Gate GaAs FET 4
13	D4	Drain GaAs FET 4
14	V _{DD}	Supply voltage
15	D1	Drain GaAs FET 1
16	G1	Gate GaAs FET 1
Pad	Gnd	Must be connected to Ground or No Connection

Maximum Ratings

Symbol	Parameter	Rating	Unit
V _{DD}	Supply Voltage	-0.6 to +6	V
I _{DD}	Supply Current	100	mA
—	Power Dissipation U-QFN3030-16 (Type B)	650	mW
T _J	Junction Temperature	+135	°C
T _{STG}	Storage Temperature Range	-40 to +150	°C

Recommended Operating Conditions (Note 8)

Symbol	Parameter	Min	Max	Unit
V _{DD}	Operating Voltage Range	2.1	5.5	V
T _A	Operating Temperature Range	-40	+105	°C

Electrical Characteristics (@T_A = +25°C, V_{DD} = 2.3V, I_{D1} to I_{D6} set to 10mA.)

Symbol	Parameter	Conditions	Min	Typ	Max	Unit
I _{DD}	Supply Current	I _{D1-6} = 0	—	1.1	2.5	mA
I _{DD(L)}		I _{D1-6} = 10mA	—	—	65	mA
V _{CSUB}	Substrate Voltage (Note 5)	I _{CSUB} = 0	-2.5	-2.0	-1.5	V
V _{CSUB(L)}		I _{CSUB} = -20μA	—	—	-1.5	V
f _{OSC}	Oscillator Frequency	—	—	7.5	—	MHz
V _{D(NOISE)}	Drain Voltage (Note 6)	C _{GATE-GND} = 10nF C _{DRAIN-GND} = 10nF	—	—	0.02	V _{PK-PK}
V _{G(NOISE)}	Gate Voltage (Note 6)	C _{GATE-GND} = 10nF C _{DRAIN-GND} = 10nF	—	—	0.005	V _{PK-PK}
Gate Characteristics						
Gate (G1 to G6)						
I _G	Current Range	—	-50	—	60	μA
V _{G(L)}	Voltage Low	I _D = 12mA, I _G = -10μA	-2.5	-2.0	-1.5	V
V _{G(H)}	Voltage High	I _D = 8mA, I _G = 0	0	0.7	1.0	V
Drain Characteristics						
Drain (D1 to D6)						
I _D	Current Range	D1 and D4	4	—	15	mA
I _{DD}		D2, D3, D5, D6 Internally Fixed	—	10	—	mA
I _{D(OP)}	Current Operating (Note 4)	Standard Application Circuit	8	10	12	mA
V _{D(OP)}	Voltage Operating (Note 7)	I _D = 10mA	1.8	2.0	2.2	V
dV _D /dV _{DD}	delta V _D vs V _{DD}	V _{DD} = 2.3V to 5.5V	—	0.075	—	%/V
dl _D /dV _{DD}	delta I _D vs V _{DD}	V _{DD} = 2.3V to 5.5V	—	0.7	—	%/V
dV _D /dT _A	delta V _D vs T _A	T _A = -40°C to +105°C	—	150	—	ppm

- Notes:
- Characteristics are measured using one external reference resistor, R_{CAL1}.
 - The negative bias voltages are generated on-chip using an internal oscillator. An external 47nF capacitor is required for this purpose.
 - Noise voltage measurements are made with FETs and gate and drain capacitors of value 10nF in place. Noise voltages are not measured in production.
 - The maximum operating drain voltage is equal to V_{DD} or V_{D(OP)} max whichever is lower.
 - ESD sensitive, handling precautions are recommended.

Typical Characteristics (@ $T_A = +25^\circ\text{C}$, $V_{DD} = 2.3\text{V}$, I_{D1} to I_{D6} set to 10mA (setting I_D to 10mA), unless otherwise stated.)

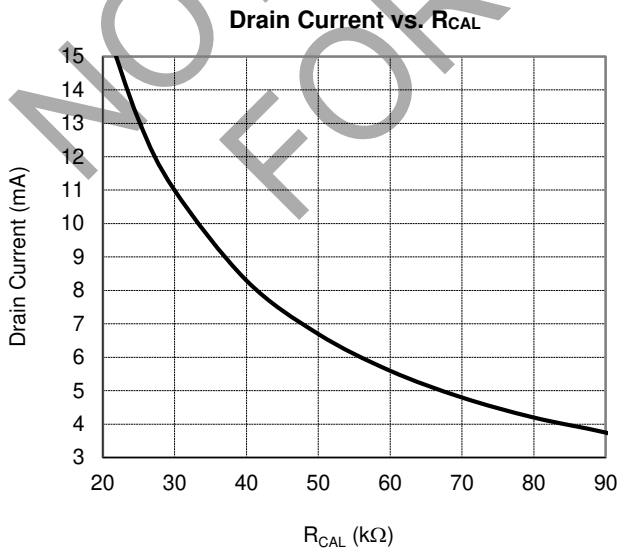
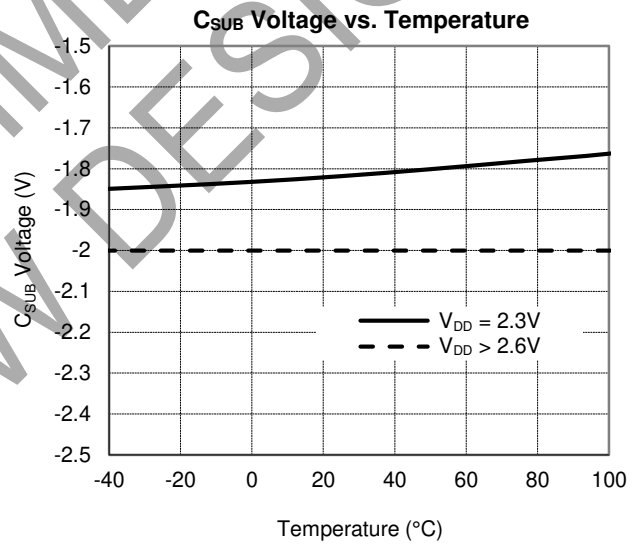
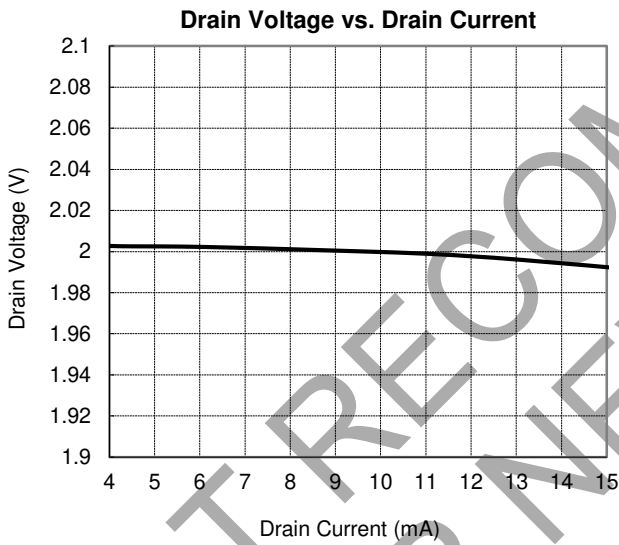
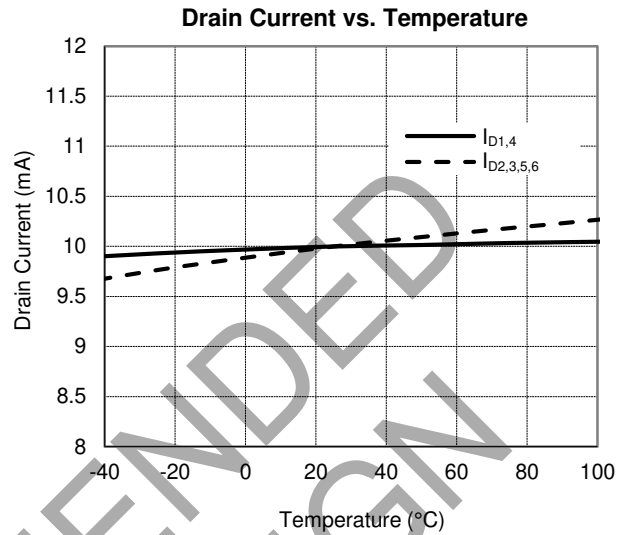
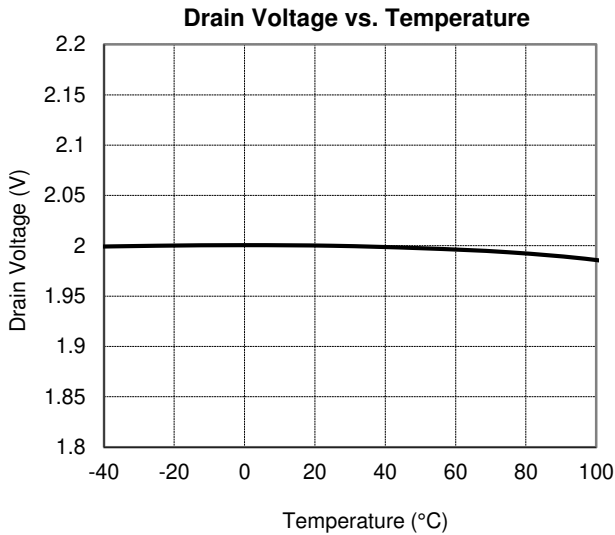

Application Information

Below is a partial applications circuit for the ZABG6003 showing all external components needed for biasing one of the six FET stages available as a typical LNA (Low Noise Amplifier). Each bias stage is provided with a gate and drain pin. The drain pin provides a regulated 2.0V supply that includes a drain current monitor. The drain current taken by the external FET is compared with a user selected level, generating a signal that adjusts the gate voltage of the FET to obtain the required drain current. If for any reason, an attempt is made to draw more than the user set drain current from the drain pin, the drain voltage will be reduced to ensure excess current is not taken. The gate pin drivers are also current limited.

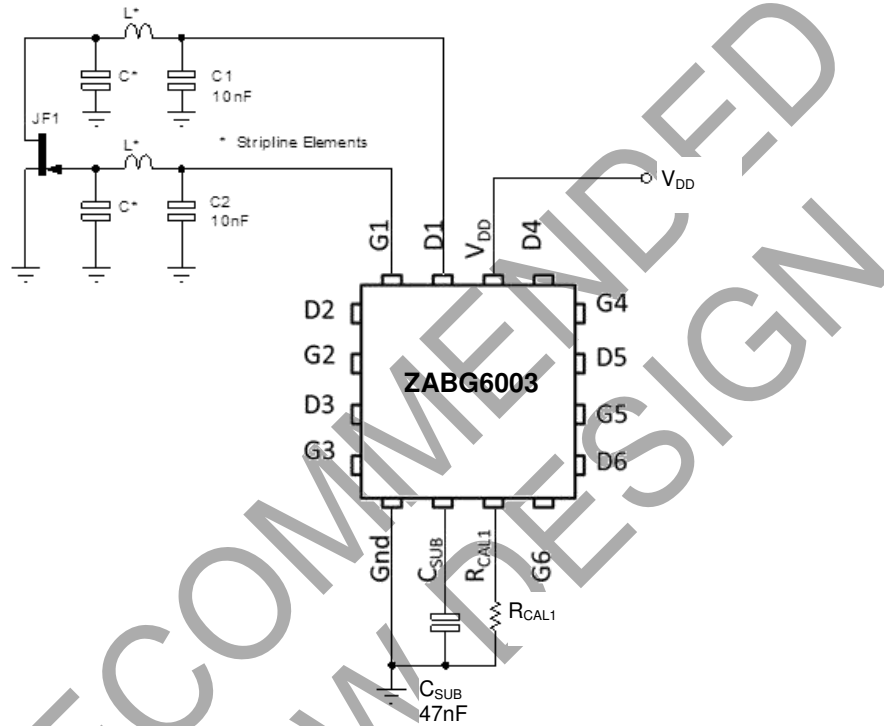

The bias stages are split up into two groups, with the drain current for D1 and D4 set by an external R_{CAL1} resistor within the range of 4mA to 15mA. Drain currents for D2, D3, D5 and D6 are internally fixed to 10mA. This allows the optimization of drain currents for differing tasks such as input stages where noise can be critical and later amplifier stages where gain may be more important. A graph showing the relationship between the value of R_{CAL} and I_D is provided in the *Typical Characteristics* section of this datasheet.

The ZABG6003 includes a switched capacitor DC-DC converter that is used to generate the negative supply required to bias depletion mode FETs used in common source circuit configuration as shown above. This converter uses an external capacitor C_{SUB} as the output reservoir capacitor. The circuit provides a regulated -2V supply both for gate driver use and for external use if required (for extra discrete bias stages, mixer bias, local oscillator bias etc.). The -2V supply is available from the C_{SUB} pin.

If any bias stages are not required, their gate and drain pins may be left open circuit. If all bias stages associated with a R_{CAL} resistor are not required, then this resistor may be omitted. The Gnd flag on the underside of the DFN package can be connected to Gnd or left open circuit.

Ordering Information

Part Number	Package	Reel Size (inches)	Tape Width (mm)	Packing	
				Qty.	Carrier
ZABG6003JA16TC	U-QFN3030-16 (Type B)	13	8	3,000	Reel

Marking Information

U-QFN3030-16 (Type B)

(Top View)

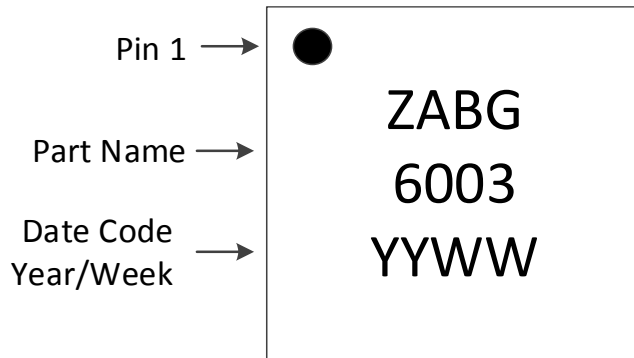

NOT RECOMMENDED FOR NEW DESIGN

Package Outline Dimensions

Please see <http://www.diodes.com/package-outlines.html> for the latest version.

U-QFN3030-16 (Type B)

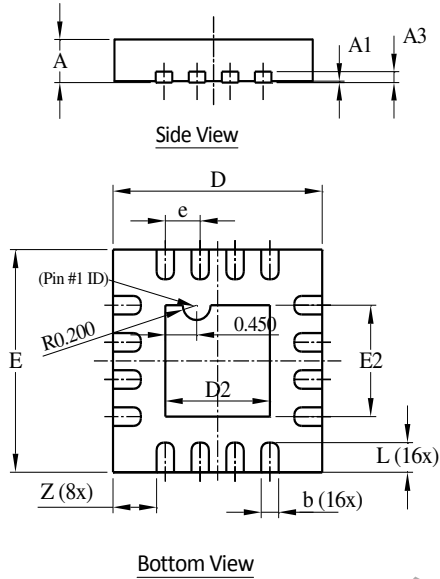

U-QFN3030-16 Type B			
Dim	Min	Max	Typ
A	0.55	0.65	0.60
A1	0	0.05	0.02
A3	-	-	0.15
b	0.18	0.28	0.23
D	2.95	3.05	3.00
D2	1.40	1.60	1.50
E	2.95	3.05	3.00
E2	1.40	1.60	1.50
e	-	-	0.50
L	0.35	0.45	0.40
Z	-	-	0.625
All Dimensions in mm			

Suggested Pad Layout

Please see <http://www.diodes.com/package-outlines.html> for the latest version.

U-QFN3030-16 (Type B)

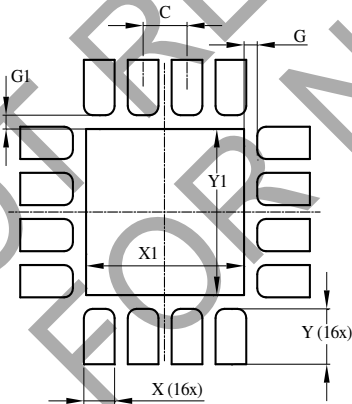

Dimensions	Value (in mm)
C	0.500
G	0.150
G1	0.150
X	0.350
X1	1.800
Y	0.600
Y1	1.800

IMPORTANT NOTICE

1. DIODES INCORPORATED (Diodes) AND ITS SUBSIDIARIES MAKE NO WARRANTY OF ANY KIND, EXPRESS OR IMPLIED, WITH REGARDS TO ANY INFORMATION CONTAINED IN THIS DOCUMENT, INCLUDING, BUT NOT LIMITED TO, THE IMPLIED WARRANTIES OF MERCHANTABILITY, FITNESS FOR A PARTICULAR PURPOSE OR NON-INFRINGEMENT OF THIRD PARTY INTELLECTUAL PROPERTY RIGHTS (AND THEIR EQUIVALENTS UNDER THE LAWS OF ANY JURISDICTION).
2. The Information contained herein is for informational purpose only and is provided only to illustrate the operation of Diodes' products described herein and application examples. Diodes does not assume any liability arising out of the application or use of this document or any product described herein. This document is intended for skilled and technically trained engineering customers and users who design with Diodes' products. Diodes' products may be used to facilitate safety-related applications; however, in all instances customers and users are responsible for (a) selecting the appropriate Diodes products for their applications, (b) evaluating the suitability of Diodes' products for their intended applications, (c) ensuring their applications, which incorporate Diodes' products, comply the applicable legal and regulatory requirements as well as safety and functional-safety related standards, and (d) ensuring they design with appropriate safeguards (including testing, validation, quality control techniques, redundancy, malfunction prevention, and appropriate treatment for aging degradation) to minimize the risks associated with their applications.
3. Diodes assumes no liability for any application-related information, support, assistance or feedback that may be provided by Diodes from time to time. Any customer or user of this document or products described herein will assume all risks and liabilities associated with such use, and will hold Diodes and all companies whose products are represented herein or on Diodes' websites, harmless against all damages and liabilities.
4. Products described herein may be covered by one or more United States, international or foreign patents and pending patent applications. Product names and markings noted herein may also be covered by one or more United States, international or foreign trademarks and trademark applications. Diodes does not convey any license under any of its intellectual property rights or the rights of any third parties (including third parties whose products and services may be described in this document or on Diodes' website) under this document.
5. Diodes' products are provided subject to Diodes' Standard Terms and Conditions of Sale (<https://www.diodes.com/about/company/terms-and-conditions/terms-and-conditions-of-sales/>) or other applicable terms. This document does not alter or expand the applicable warranties provided by Diodes. Diodes does not warrant or accept any liability whatsoever in respect of any products purchased through unauthorized sales channel.
6. Diodes' products and technology may not be used for or incorporated into any products or systems whose manufacture, use or sale is prohibited under any applicable laws and regulations. Should customers or users use Diodes' products in contravention of any applicable laws or regulations, or for any unintended or unauthorized application, customers and users will (a) be solely responsible for any damages, losses or penalties arising in connection therewith or as a result thereof, and (b) indemnify and hold Diodes and its representatives and agents harmless against any and all claims, damages, expenses, and attorney fees arising out of, directly or indirectly, any claim relating to any noncompliance with the applicable laws and regulations, as well as any unintended or unauthorized application.
7. While efforts have been made to ensure the information contained in this document is accurate, complete and current, it may contain technical inaccuracies, omissions and typographical errors. Diodes does not warrant that information contained in this document is error-free and Diodes is under no obligation to update or otherwise correct this information. Notwithstanding the foregoing, Diodes reserves the right to make modifications, enhancements, improvements, corrections or other changes without further notice to this document and any product described herein. This document is written in English but may be translated into multiple languages for reference. Only the English version of this document is the final and determinative format released by Diodes.
8. Any unauthorized copying, modification, distribution, transmission, display or other use of this document (or any portion hereof) is prohibited. Diodes assumes no responsibility for any losses incurred by the customers or users or any third parties arising from any such unauthorized use.
9. This Notice may be periodically updated with the most recent version available at <https://www.diodes.com/about/company/terms-and-conditions/important-notice>

DIODES is a trademark of Diodes Incorporated in the United States and other countries.
The Diodes logo is a registered trademark of Diodes Incorporated in the United States and other countries.
© 2022 Diodes Incorporated. All Rights Reserved.

www.diodes.com