

- 1
- 2
- 3
- 4
- 5
- 6
- 7
- 8
- 9
- 10
- 11
- 12
- 13
- 14
- 15
- 16
- 17
- 18

LOBE SOLID CAP AND COLOURED CENTRE CAP

Glass-fibre reinforced polyamide based (PA) technopolymer, black colour, matte finish, with slot for codified key.

FLANGE

Technopolymer, ultrasonically welded.

CLAMPING ELEMENT

Glass-fibre reinforced polyamide (PA) SUPER-technopolymer, black colour, matte finish.

STANDARD EXECUTIONS

- **VLSK-B:** brass boss, threaded pass-through hole, with cap.
- **VLSK-FP:** brass boss, threaded pass-through hole, without cap.
- **VLSK-p:** zinc-plated steel threaded stud, chamfered flat end UNI 947 : ISO 4753 (see Technical data on page A-10), with cap.

Indexes to add to the above mentioned executions:

- **F:** lock with 210 different combinations; each lock has a couple of keys with different combination, removable in two positions at 180°.
- **U:** lock with one combination; all locks have the same combination and can be opened with the same key removable in two positions at 180°.

LOCK AND KEYS

Die cast zinc alloy rotor and stator.

The lock has got a red protection tab for closing the lock when the key is not inserted.

Two keys made out of nickel-plated brass and technopolymer.

SECURITY DEVICE OPERATION

VLSK security lobe knob has been designed to prevent its unscrewing by unauthorised people. Therefore, it has got a vandal-proof function as well.

For clamping and unscrewing the knob, insert the special key into the lock and turn it by 180°. By so doing the clamping element and the knob form a single body. When the lock is brought back to the starting position and the key is removed, the knob turns freely preventing the unscrewing.

FEATURES AND APPLICATIONS

The particular design of the internal device and of the flange helps the drainage of any dirt (dust, earth or liquid).



ELESA Original design

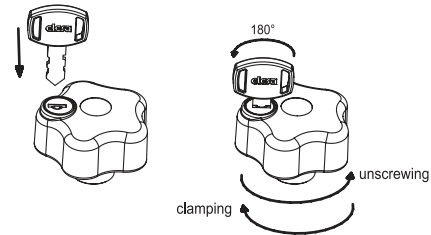
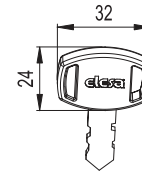

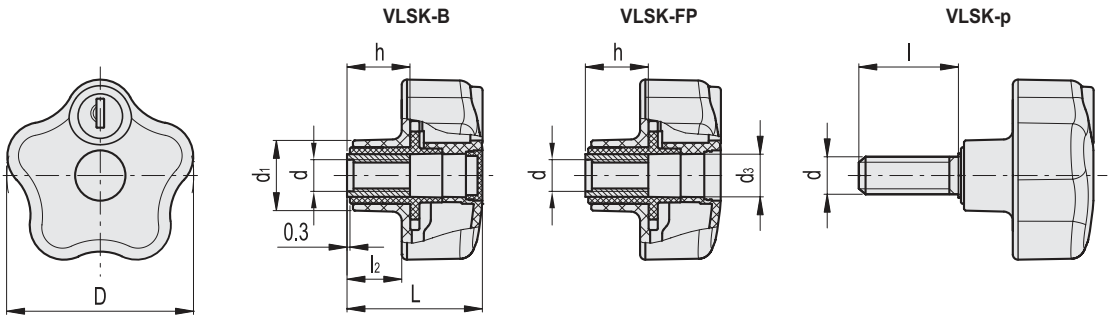

Conversion Table	
1 mm = 0.039 inch	
D	
mm	inch
63	2.48

VLSK-B

METRIC

Code	Description	D	d6H	L	d1	l2	h	⚖️
76701	VLSK.63 B-M6-F	63	M6	44	23	17	18	95
76702	VLSK.63 B-M8-F	63	M8	44	23	17	18	94
76703	VLSK.63 B-M10-F	63	M10	44	23	17	20	93
76801	VLSK.63 B-M6-U	63	M6	44	23	17	18	95
76802	VLSK.63 B-M8-U	63	M8	44	23	17	18	94
76803	VLSK.63 B-M10-U	63	M10	44	23	17	20	93

VLSK-FP

METRIC

Code	Description	D	d6H	L	d1	d3	l2	h	⚖️
76711	VLSK.63 FP-M6-F	63	M6	44	23	14	17	18	95
76712	VLSK.63 FP-M8-F	63	M8	44	23	14	17	18	94
76713	VLSK.63 FP-M10-F	63	M10	44	23	14	17	20	93
76811	VLSK.63 FP-M6-U	63	M6	44	23	14	17	18	95
76812	VLSK.63 FP-M8-U	63	M8	44	23	14	17	18	94
76813	VLSK.63 FP-M10-U	63	M10	44	23	14	17	20	93

VLSK-p

METRIC

Code	Description	D	d6g	L	d1	l	l2	⚖️
76731	VLSK.63 p-M8x20-F	63	M8	44	23	20	17	106
76741	VLSK.63 p-M10x20-F	63	M10	44	23	20	17	107
76831	VLSK.63 p-M8x20-U	63	M8	44	23	20	17	106
76841	VLSK.63 p-M10x20-U	63	M10	44	23	20	17	107

Clamping knobs