

Restrictions:

IDT's ZSPM8735-KIT Evaluation Kit hardware and the Pink Power Designer™ software are designed only for evaluation of the ZSPM1035C PWM Controller IC and the Murata OKLP-X/35-W12-C Power Block; laboratory setup; and module development. The kit hardware and software must not be used for module production and production test setups.

IDT shall not be liable for any damages arising out of defects resulting from (i) delivered hardware and software, (ii) non-observance of instructions contained in this manual, or (iii) misuse, abuse, use under abnormal conditions, or alteration by anyone other than IDT. To the extent permitted by law, IDT hereby expressly disclaims and User expressly waives any and all warranties, whether express, implied, or statutory, including, without limitation, implied warranties of merchantability and of fitness for a particular purpose, statutory warranty of non-infringement, and any other warranty that may arise by reason of usage of trade, custom, or course of dealing.



Important Safety Warning: These procedures can result in high currents, which can cause severe injury or death. Only trained professional staff should connect external equipment. Ensure that all staff have read and understood this document and the high voltage safety disclaimer that is included with the kit.

Contents

1	Introduction.....	3
1.1.	Kit Contents	3
2	ZSPM8735 Evaluation Board.....	4
2.1.	Evaluation Board Overview	4
2.2.	General Setup for the Evaluation System	6
2.2.1.	User Instrumentation.....	6
2.2.2.	User Computer.....	7
3	Software Installation and Setup.....	7
4	Pink Power Designer™ Software Overview.....	8
5	Evaluation Kit Setup for a 1.2V Output Voltage	9
6	Evaluation Board Hardware Setup.....	11
6.1.	Introduction	11
6.2.	Output Voltage Selection.....	11
6.3.	Output Capacitor Range Selection	12
6.3.1.	Output Capacitor Range Test Procedure	13
6.4.	On-Board Transient Loads	13
7	Support	15
8	Related Documents.....	15
9	Definitions of Acronyms.....	15
10	Document Revision History.....	16
	Appendix A: ZSPM8735 Evaluation Board.....	17
	Appendix B: ZSPM8735 Evaluation Board Schematic.....	18

List of Figures

Figure 1.1	ZSPM8735-KIT Evaluation Kit Contents	3
Figure 2.1	ZSPM8735-KIT Evaluation Board (Top Side).....	5
Figure 2.2	ZSPM8735-KIT Evaluation Board (Bottom Side)	6
Figure 2.3	Pink Power Evaluation Kit Setup	6
Figure 4.1	The Pink Power Designer™ GUI	8
Figure 5.1	ZSPM8735-KIT – PMBus™CI Connection (Top Side of the PCB)	10
Figure 5.2	Control Pin Button.....	10
Figure 6.1	J106 - Output Capacitor Range Hardware Selection	12
Figure 6.2	J100 and J101 – Transient Load Selection	14
Figure 6.3	Timing for the On-Board Transient Loads	14

1 Introduction

This document describes the use of IDT's ZSPM8735-KIT for evaluating DC/DC point-of-load (POL) applications and provides additional kit information, including the circuit diagram and board layout. The kit incorporates IDT's ZSPM1035C digital PWM controller IC and the Murata OKLP-X/35-W12-C Power Block to form a "smart" buck converter (a.k.a. step-down DC-to-DC converter).

The ZSPM8735-KIT Evaluation Kit hardware functions with the ZSPM1035C Pink Power Designer™ graphical user interface (GUI), which is used for monitoring the internal measurements and fault conditions of the ZSPM1035C. The GUI software must be downloaded to the user's PC from the IDT website to ensure receiving the latest release as described in section 3. See section 2.2.2 for the requirements for the user's PC.

The PMBus™ Communication Interface (CI) provides the interface between the ZSPM8735-KIT Evaluation Kit and the user's PC.

1.1. Kit Contents

- ZSPM8735 Evaluation Board
- PMBus™ Communication Interface (CI)
- USB Cable
- *Startup Information* document
- *Safety Disclaimer* document

Figure 1.1 ZSPM8735-KIT Evaluation Kit Contents

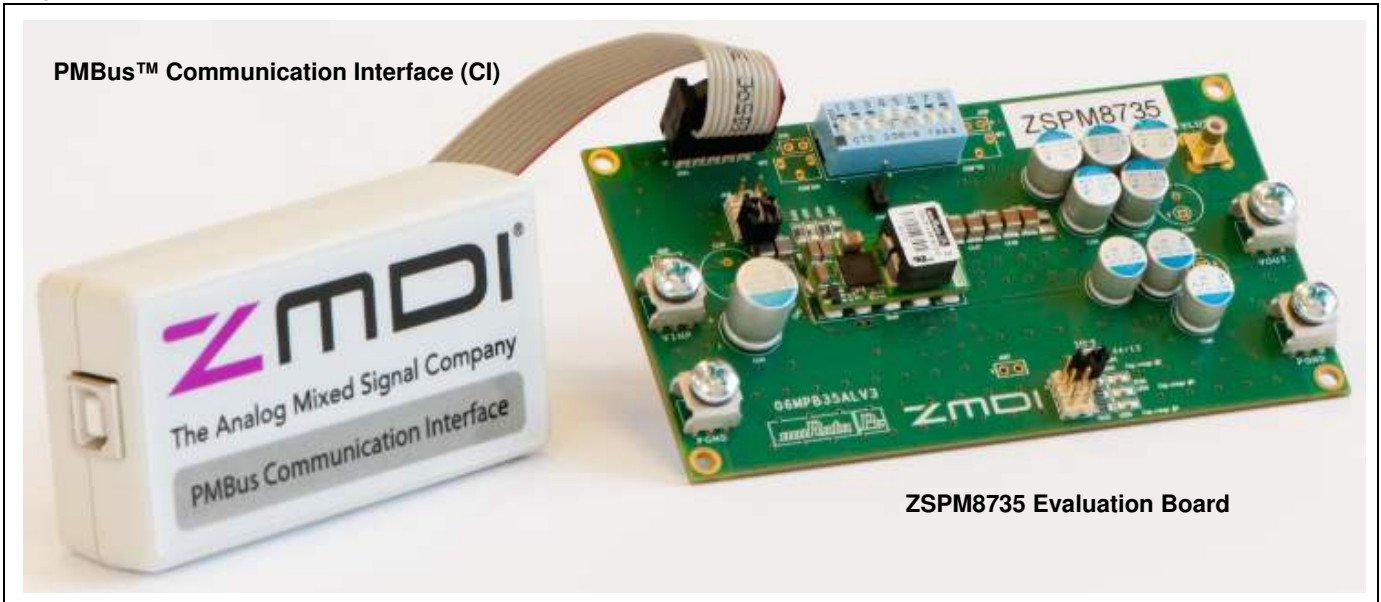

2 ZSPM8735 Evaluation Board

2.1. Evaluation Board Overview

The ZSPM8735 Evaluation Kit provides all the necessary components for a first evaluation of IDT's ZSPM1035C digital PWM controller. The ZSPM1035C can be configured using two pin-strap resistors to select the output voltage and the control loop performance. See the *ZSPM1035C Data Sheet* for more details.

In addition to the ZSPM1035C controller, the Evaluation Board features the Murata OKLP-X/35-W12-C Power Block. The number of output capacitors can be selected with a jumper on the Evaluation Board. The electrical specifications can be found in Table 2.1, and the schematic is provided in Appendix B.

Table 2.1 Key Design Parameters for the Evaluation Kit Power Stage

Parameter	Value
Input voltage	7 – 13.2V
Output voltage	Up to 1.2V
Maximum output current	35A
Switching frequency	500kHz

The board also provides the connections needed for digital communication between the ZSPM1035C and the GUI software via the PMBus™ Communications Interface (CI).

An on-board transient load is also provided for generating load transients with high current slew rates.

Figure 2.1 shows the ZSPM8735 Evaluation Board and the board connections that will be completed in the subsequent setup steps. Do not make the connections at this point. Note that some settings for the DIP switches are not allowed; therefore, before using the kit, ensure that switches 4 and 5 are in the “ON” position and the rest of the switches are in the “OFF” position as shown in Figure 2.1.

Figure 2.1 ZSPM8735-KIT Evaluation Board (Top Side)

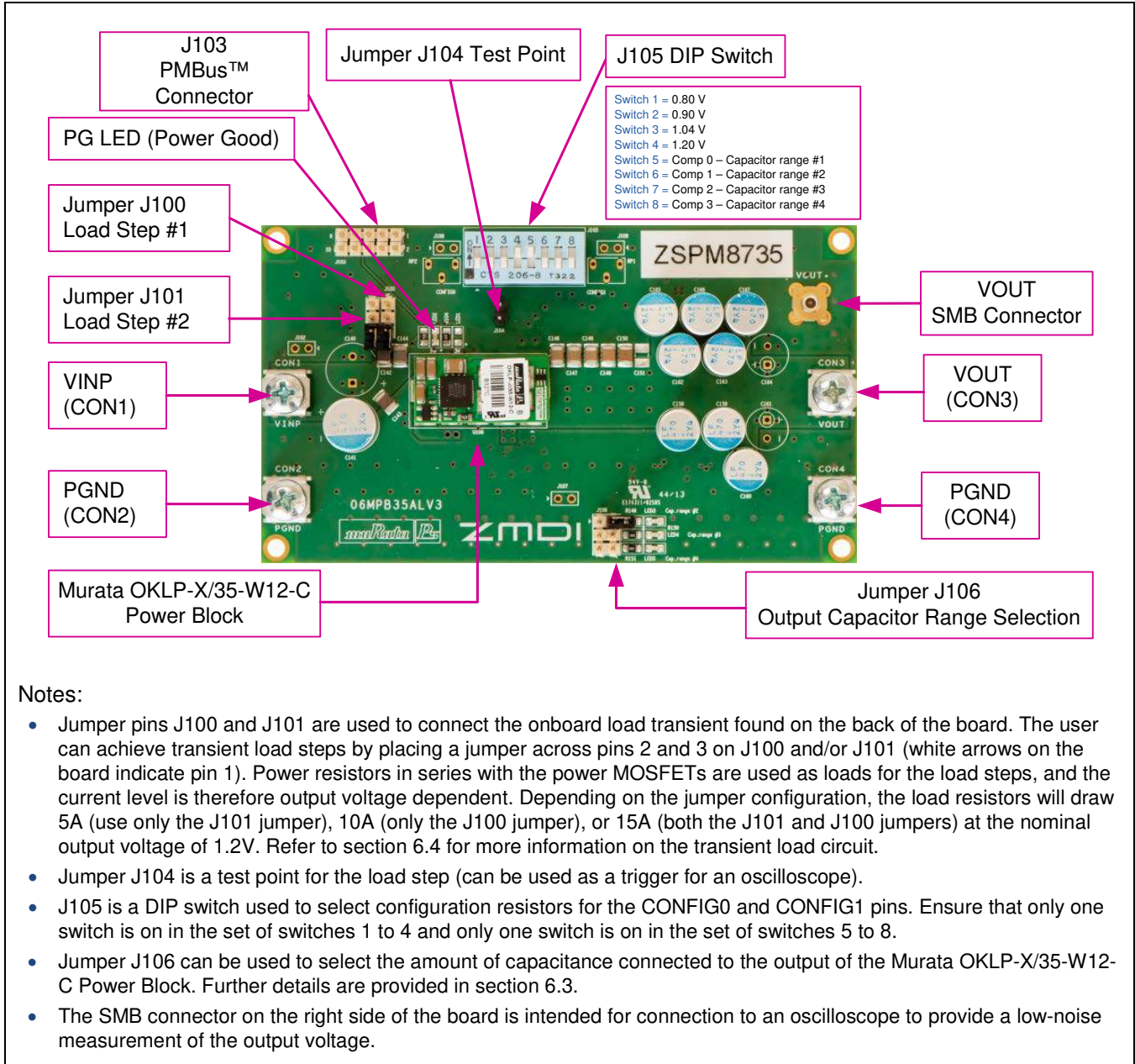

Notes:

- Jumper pins J100 and J101 are used to connect the onboard load transient found on the back of the board. The user can achieve transient load steps by placing a jumper across pins 2 and 3 on J100 and/or J101 (white arrows on the board indicate pin 1). Power resistors in series with the power MOSFETs are used as loads for the load steps, and the current level is therefore output voltage dependent. Depending on the jumper configuration, the load resistors will draw 5A (use only the J101 jumper), 10A (only the J100 jumper), or 15A (both the J101 and J100 jumpers) at the nominal output voltage of 1.2V. Refer to section 6.4 for more information on the transient load circuit.
- Jumper J104 is a test point for the load step (can be used as a trigger for an oscilloscope).
- J105 is a DIP switch used to select configuration resistors for the CONFIG0 and CONFIG1 pins. Ensure that only one switch is on in the set of switches 1 to 4 and only one switch is on in the set of switches 5 to 8.
- Jumper J106 can be used to select the amount of capacitance connected to the output of the Murata OKLP-X/35-W12-C Power Block. Further details are provided in section 6.3.
- The SMB connector on the right side of the board is intended for connection to an oscilloscope to provide a low-noise measurement of the output voltage.

Figure 2.2 ZSPM8735-KIT Evaluation Board (Bottom Side)

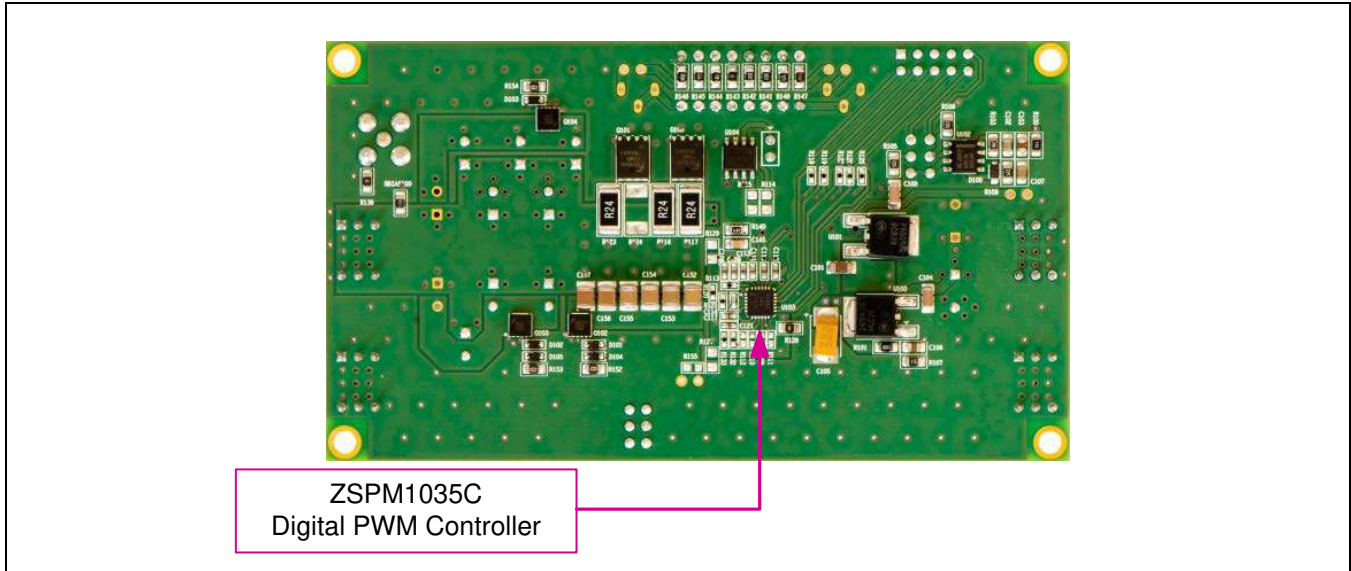

2.2. General Setup for the Evaluation System

The basic setup for using the ZSPM8735 Evaluation Kit is illustrated in Figure 2.3. The pink shaded blocks and the cables are the kit.

Figure 2.3 Pink Power Evaluation Kit Setup

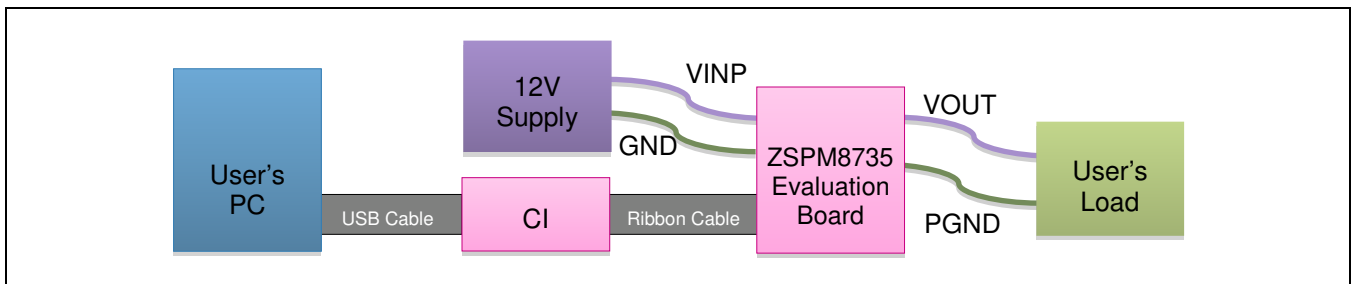

2.2.1. User Instrumentation

The following user equipment is required or recommended for demonstrating the features of the ZSPM1035C controller and the Murata OKLP-X/35-W12-C with the Evaluation Kit:

- **DC power supply:** An external power supply is required for the ZSPM8735 Evaluation Board. Its output voltage must be at least 12V with a rated output current of approximately 1A to 5A depending on the test conditions.

- **Electronic load:** An external DC load is highly recommended as the Evaluation Board features only transient loads due to constraints in power dissipation. While an electronic load can be very advantageous, load resistors could also be sufficient for testing. Ensure that the electronic load has an adequate power rating.
- **Oscilloscope:** Connecting an oscilloscope to the Evaluation Kit is strongly recommended for measuring the performance of the Evaluation Board in the time domain. The Evaluation Board features an SMB connector connected to the output of the power stage for easy connection to an oscilloscope.

2.2.2. User Computer

A Windows®-based computer (PC) is required for interfacing with the ZSPM8735 Evaluation Board through the PMBus™ Communication Interface. The user will need administrative rights on the PC to download and install the Pink Power Designer™ GUI for the kit. The PC must meet the following requirements:

- Windows® XP or Windows® 7
- Internet access

3 Software Installation and Setup

The software for the ZSPM8735 KIT is the ZSPM1035C Pink Power Designer™ graphical user interface (GUI), which is required to monitor the internal measurement and fault conditions of the ZSPM1035C. The Pink Power Designer™ must be downloaded from the ZSPM1035C product page on IDT's website located at www.IDT.com/ZSPM1035C.

1. Click on this link on the ZSPM1035C product page to download the zip file for the GUI: **Pink Power Designer(TM) GUI for ZSPM1035C/D Rev. X.x.y** (X.x.y refers to the latest version of the file.)
2. Extract the executable file *ZMDI_ZSPM1035CD_PPDGui_X.x.y_win32-setup.exe* from the zip file.
3. Install the Pink Power Designer™ GUI software by clicking on the extracted file *ZMDI_ZSPM1035CD_PPDGui_X.x.y_win32-setup.exe*.

4 Pink Power Designer™ Software Overview

This section gives a brief introduction to the Pink Power Designer™ software. For full instructions for using the software, refer to the *Pink Power Designer™ Graphic User Interface (GUI) for the ZSPM1035C/D*, which is included in the software and can also be downloaded from the ZSPM1035C product page on IDT's web site (www.IDT.com/ZSPM1035C). To open it from within the GUI, click “Help” on the top menu of the Pink Power Designer™ GUI and then click “User Guide” (see Figure 4.1).

The Pink Power Designer™ is a graphic user interface (GUI) designed by IDT to enable the user to monitor the internal measurements and fault conditions on the evaluation or application board. The Pink Power Designer™ GUI includes a wizard that will guide the user through a simple selection process to select the controller under test. The display is structured with a main window and a side panel on the left side for status information.

Figure 4.1 The Pink Power Designer™ GUI

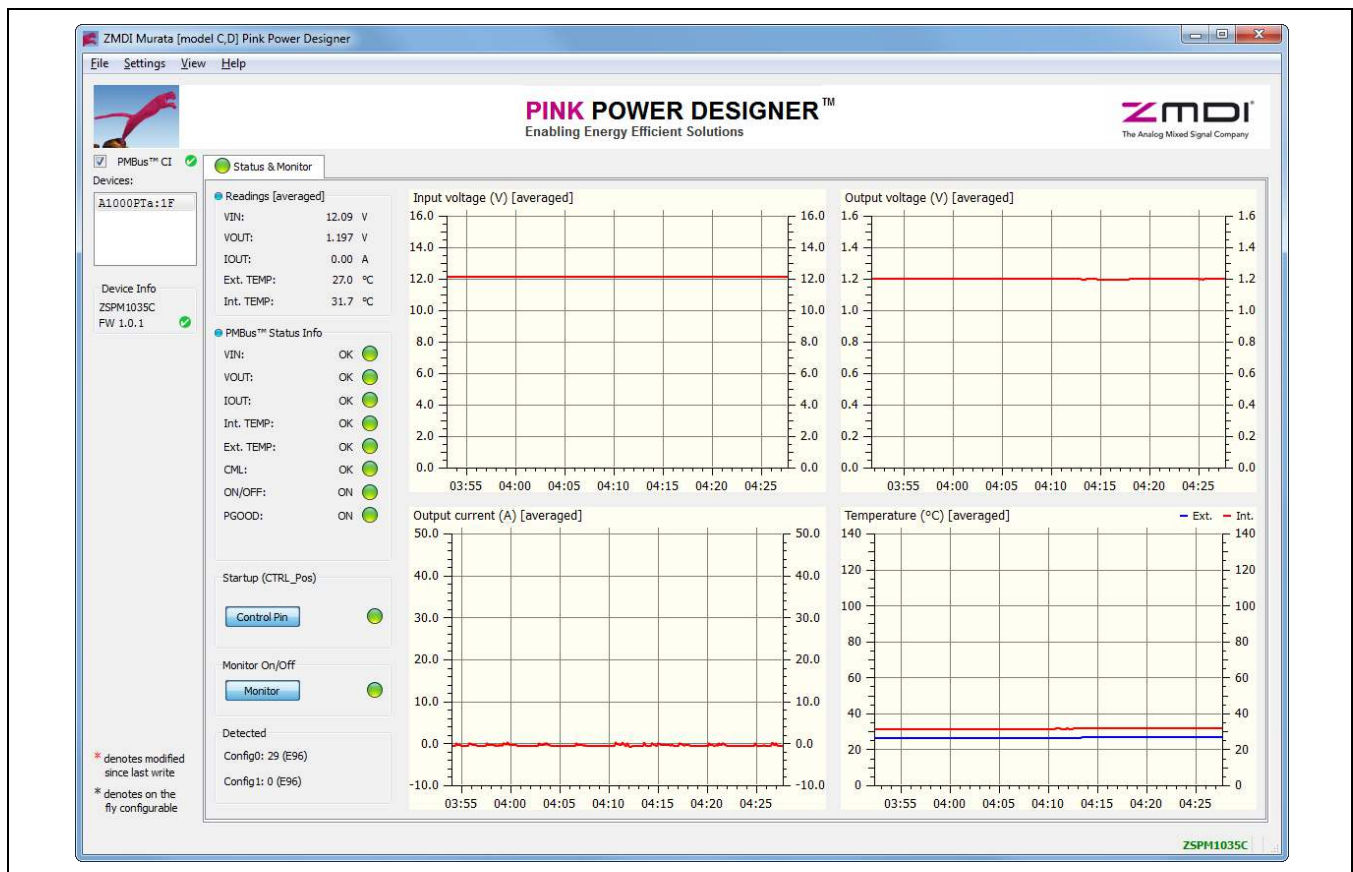

The “Murata Power Block” Wizard

Upon start-up of the GUI, a wizard will guide the user through a simple selection process. The wizard will select the correct configuration data for the ZSPM1035C controller.

The Side Panel

The side panel provides information about the status of the PMBus™ CI and the device connected to the PMBus™ CI.

The Status & Monitor Tab

The “Status & Monitor” provides monitoring of voltage, current, and temperatures. The status of the internal fault monitoring is shown.

The CONTROL pin of the ZSPM1035C can be toggled to enable or disable the output of the ZSPM8735 Evaluation Board. The pin strap configuration indexes for the CONFIG0 and CONFIG1 are displayed in the bottom left corner. Refer to the *ZSPM1035C Data Sheet* for definitions of the configuration indexes.

5 Evaluation Kit Setup for a 1.2V Output Voltage

This section covers the steps for powering up the ZSPM8735 Evaluation Kit for the first time.



Important Safety Warning: The following procedures can result in high currents, which can cause severe injury or death. Only trained professional staff should connect external equipment. Do not enable the power supply connected to the input terminals until indicated in the following steps.

Follow this step-by-step instruction to power up the ZSPM8735 Evaluation Board:

- Step 1:** Set switches 4 and 5 on DIP switch J105 to ON and make sure no jumper is placed on header J106. The remainder of the switches must be in the OFF position. This selects the standard configuration for the ZSPM8735 Evaluation Board. The standard configuration has an output voltage of 1.2V and operates with the lowest output capacitor range.
- Step 2:** Connect the power supply to the connectors labeled CON1 (VINP in Figure 2.1) and CON2 (PGND). Connect the load to the CON3 (VOUT) and CON4 (PGND) connectors. The load can be either a resistor or an electronic load. Connect the PMBus™ CI to connector J103 with the orientation shown in Figure 5.1 (pin 1 is labeled on the board) and use the USB cable to connect the CI and to a USB port on the user’s PC.
- Step 3:** Start the Pink Power Designer™ and follow the instructions given in the *Pink Power Designer™ Graphic User Interface (GUI) Guide for the ZSPM1035C /D* to select the Murata OKLP-X/35-W12-C Power Block and the ZSPM1035C controller via the Murata Power Block Wizard. Then click “Finish” to proceed to the main window of the GUI.

- Step 4:** Set the power supply voltage to 12V and enable the output of the power supply. If the power supply has no enable button ensure that the output voltage is set to 12V before connecting it to the ZSPM8735 Evaluation Board. The Pink Power Designer™ GUI will now recognize the ZSPM1035C and show the device in the status panel on the left side of the screen.
 Note: Because the ZSPM1035C has not yet been enabled by the GUI, there should be no voltage present on the output connectors of the ZSPM8735 Evaluation Board at this time.
- Step 5:** Ensure that monitoring of the input voltage, output voltage, output current, and the readings of internal and external temperature is active. The virtual LED next to the “Monitor” button will be green when monitoring is enabled (see Figure 5.2). Click on the “Monitor” button to enable monitoring if the virtual LED is not green.
- Step 6:** Click on the “Control Pin” button located in the “Startup” subsection to enable the output of the ZSPM8735 Evaluation Board. The power-good (PG) LED on the board should be on now as shown in Figure 2.1, and a voltage of 1.2V should be present on the output terminals.

Figure 5.1 ZSPM8735-KIT – PMBus™CI Connection (Top Side of the PCB)

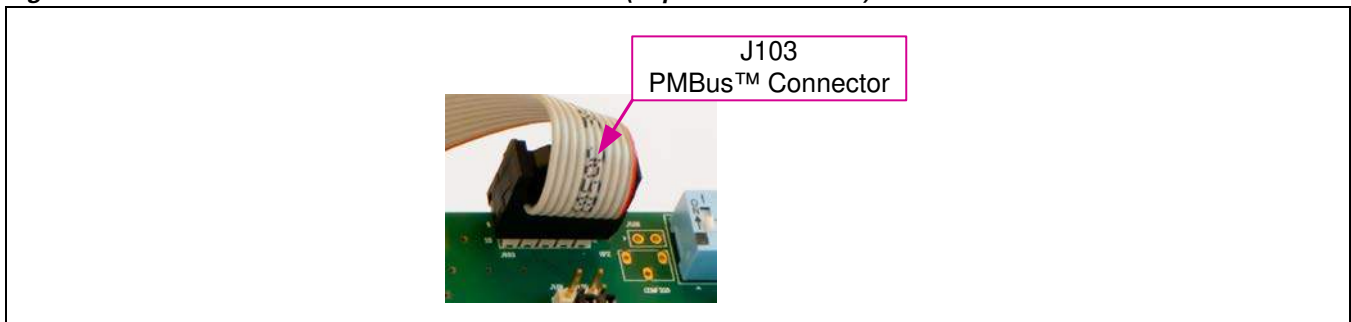
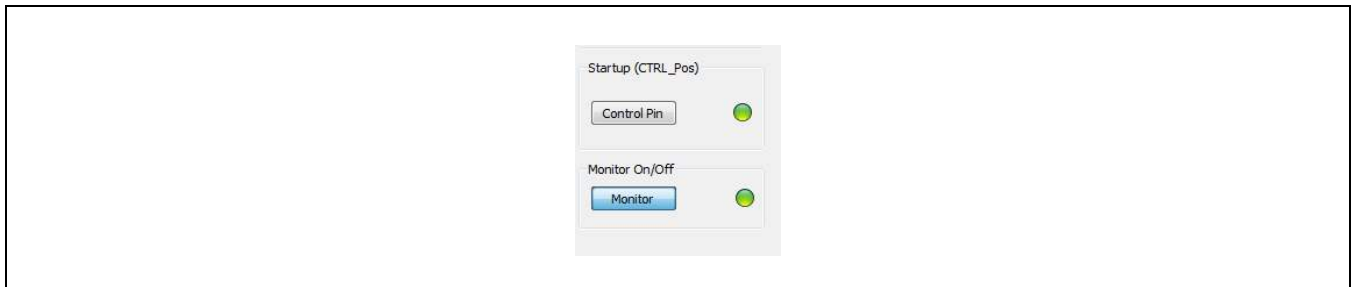

Figure 5.2 Control Pin Button



6 Evaluation Board Hardware Setup

6.1. Introduction

The ZSPM1035C PWM controller has two configuration pins that support pin strapping of the following parameters:

- Output Voltage, VOUT
- Compensation Loop Parameters
- Output Voltage Slew Rate (this parameter is permanently preconfigured to be 10 V/ms on the Evaluation Board)

The output voltage is set with a pin strap resistor between the CONFIG0 pin and the AGND pin of the ZSPM1035C that is selected with the J105 DIP switch. Refer to section 6.2 for more information on the output voltage selection on the ZSPM8735 Evaluation Board. The *ZSPM1035C Data Sheet* provides detailed information about the output voltage selection of the ZSPM1035C.





The ZSPM1035C has four pre-configured compensators that are selectable with a pin-strap resistor between the CONFIG1 pin and AGND that is selected with the J105 DIP switch. The four compensators have been designed to work for specific ranges of output capacitors. Section 6.3 describes how the Evaluation Board can be configured for any of the four capacitor ranges, thereby enabling simple comparisons of the dynamic performance of the complete solution. The *ZSPM1035C Data Sheet* provides further information about the compensation loop configurations of the ZSPM1035C controller and typical performance measurements.

6.2. Output Voltage Selection

The ZSPM1035C has been pre-configured for 30 different output voltages (see the *ZSPM1035C Data Sheet*) selectable by a pin-strap resistor between the CONFIG0 pin and AGND. Four common output voltages can be selected with DIP switch J105 on the ZSPM8735 Evaluation Board.

Important: Ensure that for the set of switches 1 through 4 on DIP switch J105, only one switch is in the ON position.

Table 6.1 ZSPM8735 Evaluation Board - Output Voltage Selection

Output Voltage VOUT	DIP Switch J105	Output Voltage VOUT	DIP Switch J105
0.80V		1.04V	
0.90V		1.20V	

Follow these steps to change the output voltage:

1. Ensure that the input voltage for the ZSPM8735 Evaluation Board is OFF.
2. Select the nominal output voltage by setting the DIP switch corresponding to the required output voltage to the “ON” position. Ensure that the three remaining DIP switches are in the “OFF” position.
3. Apply the input voltage to the ZSPM8735 Evaluation Board.
4. Enable the output voltage by clicking the “Control Pin” in the Pink Power Designer GUI™.

6.3. Output Capacitor Range Selection

The ZSPM1035C controllers have been pre-configured with four sets of compensation loop parameters. Each set of compensation parameters has been designed to match a range of output capacitance (see the *ZSPM1035C Data Sheet* for more information on the output capacitor ranges). The Evaluation Board enables the customer to test the performance of the controller for each of the four output capacitor ranges. A minimum of ceramic capacitors are always present on the output of the Murata OKLP-X/35-W12-C Power Block (capacitor range #1, no jumper on J106) and further capacitor banks can be selected with a jumper on header J106 (see Table 6.2). The type and number of capacitors connected to the output for each range are listed in Table 6.2. On the Evaluation Board, one of the three LEDs adjacent to J106 will turn green to indicate if capacitor range #2, #3, or #4 has been selected (see Figure 6.1). If none of the LEDs are on, it means that capacitor range #1 has been selected.

Figure 6.1 J106 - Output Capacitor Range Hardware Selection

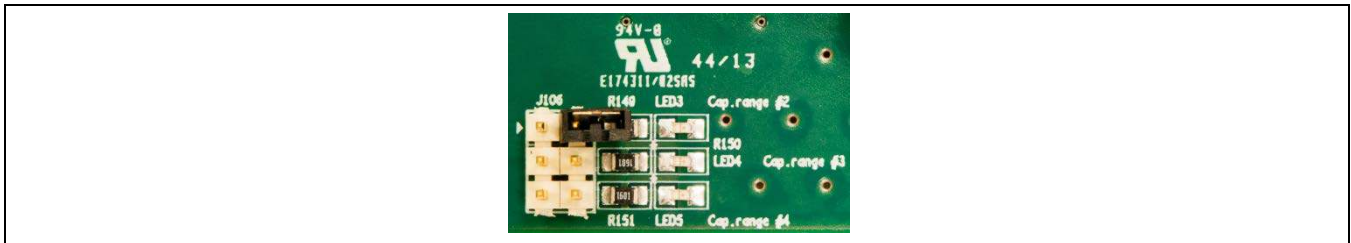







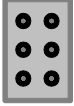

It is important to ensure that the output capacitor range selected on J106 matches the compensator selected for the ZSPM1035C. The compensator can be selected on DIP switch J105 on switches 5 through 8 (see Table 6.2).

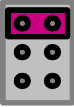
Important: Ensure that for the set of switches 5 through 8 on DIP switch J105, only one switch is in the ON position.

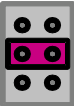
The output voltage slew rate is always set to 10 V/ms on the ZSPM8735 Evaluation Board.

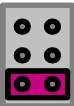
Table 6.2 ZSPM8735 Evaluation Board – Output Capacitor Range Selection

Capacitor Range	Ceramic Capacitor	Bulk Electrolytic Capacitors	Header J106	DIP Switch J105
#1	3 x 100 μ F 6.3V X5R 2 x 47 μ F 10V X7R	None		 Comp0 Setting
#2	7 x 100 μ F 6.3V X5R 4 x 47 μ F 10V X7R	None		 Comp1 Setting
#3	3 x 100 μ F 6.3V X5R 2 x 47 μ F 10V X7R	3 x 470 μ F, 7m Ω ESR		 Comp2 Setting
#4	7 x 100 μ F 6.3V X5R 4 x 47 μ F 10V X7R	8 x 470 μ F, 7m Ω ESR		 Comp3 Setting

6.3.1. Output Capacitor Range Test Procedure

To test the performance of the four selectable compensators, follow these simple steps:

1. Ensure that the input voltage for the ZSPM8735 Evaluation Board is OFF.
2. Select the output capacitor range via header J106.
3. Select the compensator matching the output capacitor range using positions 5 through 8 on the J105 DIP switch.
4. Select the nominal output voltage using positions 1 through 4 on the J105 DIP switch.
5. Apply the input voltage to the ZSPM8735 Evaluation Board.
6. Enable the output voltage by clicking the “Control Pin” in the Pink Power Designer GUI™.
7. Test the dynamic performance using either the on-board transient loads or an external electronic load.

6.4. On-Board Transient Loads

The ZSPM8735 Evaluation Board has on-board transient loads that can be used to test the dynamic performance of the ZSPM1035C controller. The transient loads consist of a simple timer circuit driving a power MOSFET. The power MOSFET is connected in series with resistors connected across the output of the Murata OKLP-X/35-W12-C Power Block. A schematic of the transient load circuitry is provided in Appendix B.

There are two transient loads that can be enabled on headers J100 and J101 (see Figure 6.2). The two loads can be enabled at the same time to achieve a larger current step. The timing signal for the transient loads has an ON time of approximately 1 millisecond with a time period of approximately 80 milliseconds (see Figure 6.3).

Important: The load current is a function of the nominal output voltage set on DIP switch J105 and the resistance of the transient load. Be sure to calculate the expected load current before enabling the transient loads.

Figure 6.2 J100 and J101 – Transient Load Selection

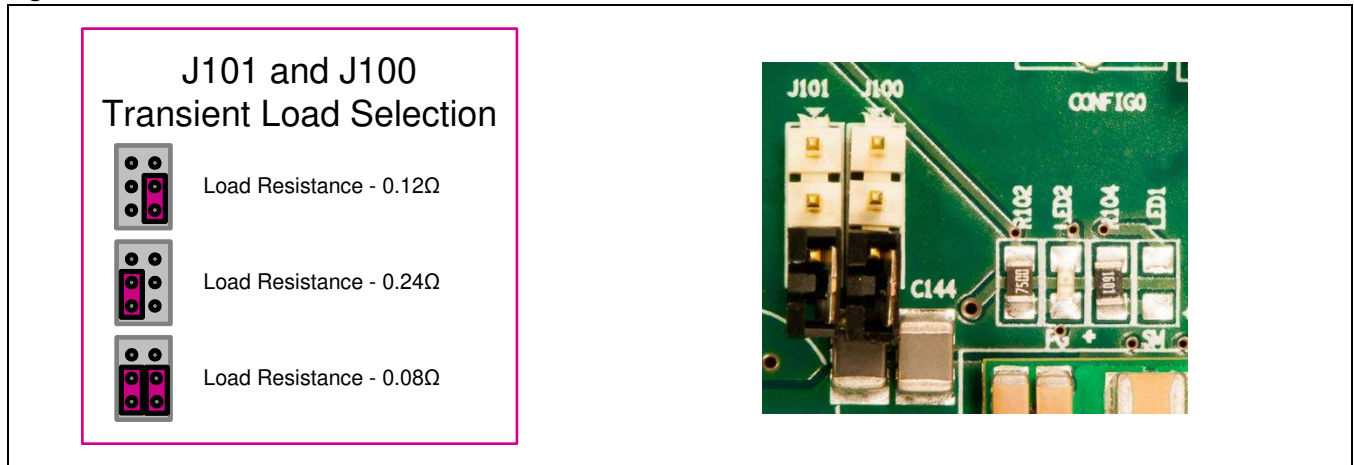
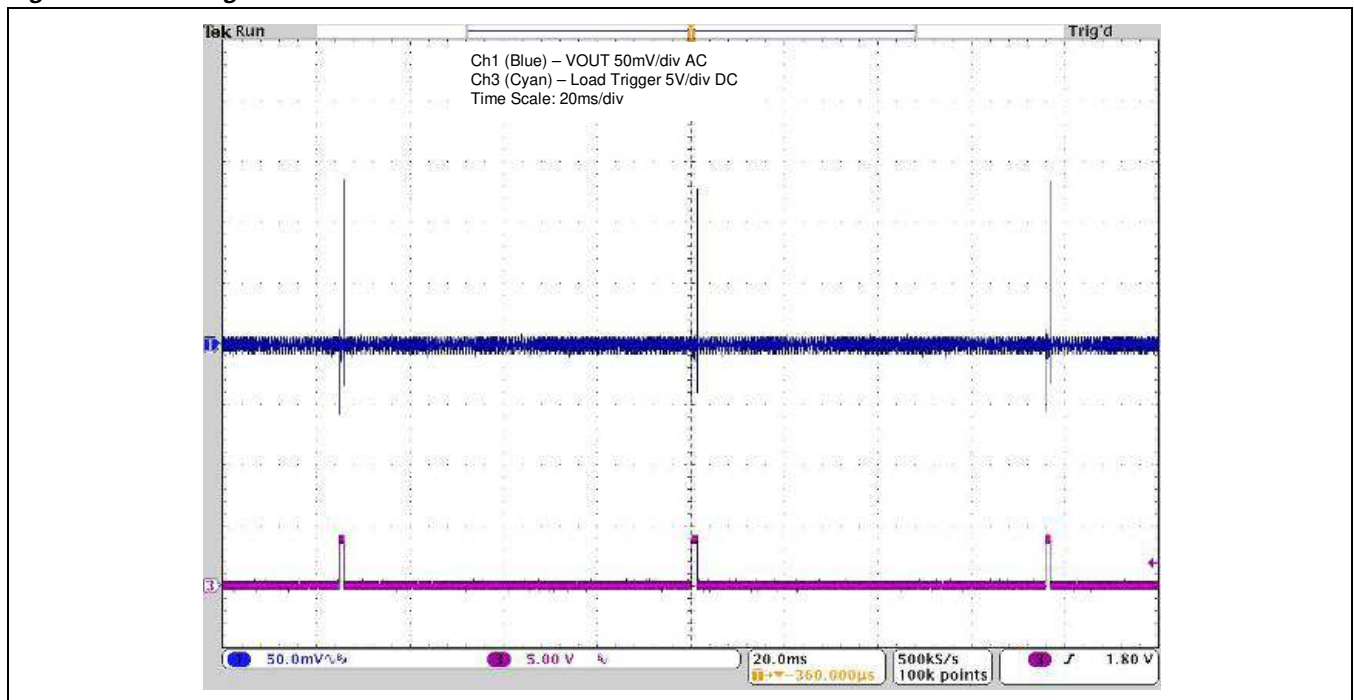

Figure 6.3 Timing for the On-Board Transient Loads



7 Support

IDT provides additional support tools for the ZSPM8735-KIT and the IDT Pink Power Designer™ at www.IDT.com. If further support is needed, contact IDT at www.IDT.com/go/support.

8 Related Documents

Document
<i>ZSPM1035C Data Sheet</i>
<i>Pink Power Designer™ Graphic User Interface (GUI) Guide for the ZSPM1025C/D and ZSPM1035C/D</i>

Visit the ZSPM1035C product page at www.IDT.com/ZSPM1035C or contact your nearest sales office for the latest version of these documents.

9 Definitions of Acronyms

Term	Description
DIP	Dual In-line Package
PWM	Pulse Width Modulation

10 Document Revision History

Revision	Date	Description
1.00	January 23, 2014	First release.
1.01	June 13, 2014	Updated cover imagery and contact information. Updated images of software.
	April 14, 2016	Changed to IDT branding.

Appendix A: ZSPM8735 Evaluation Board

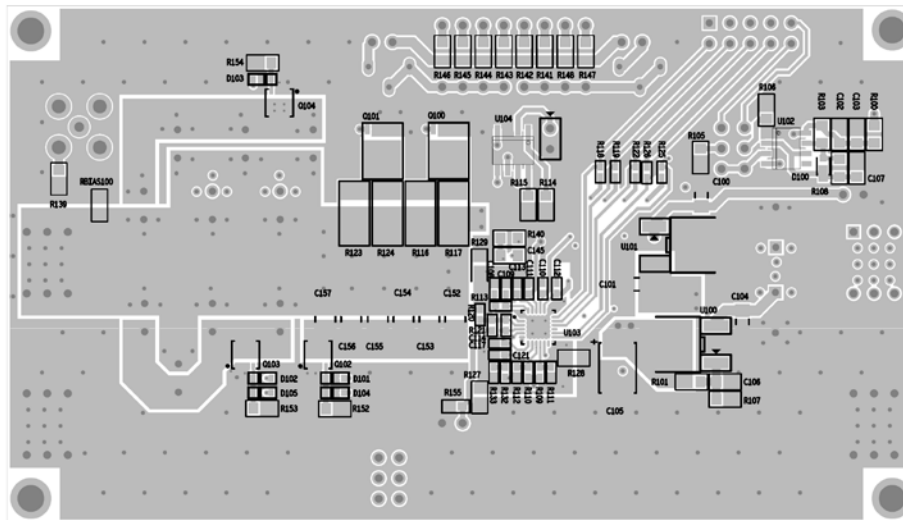
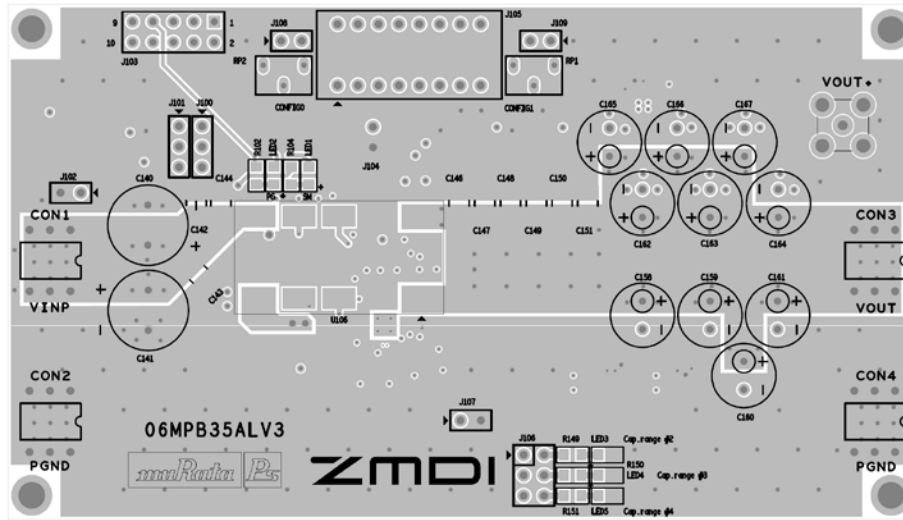

Appendix B: ZSPM8735 Evaluation Board Schematic

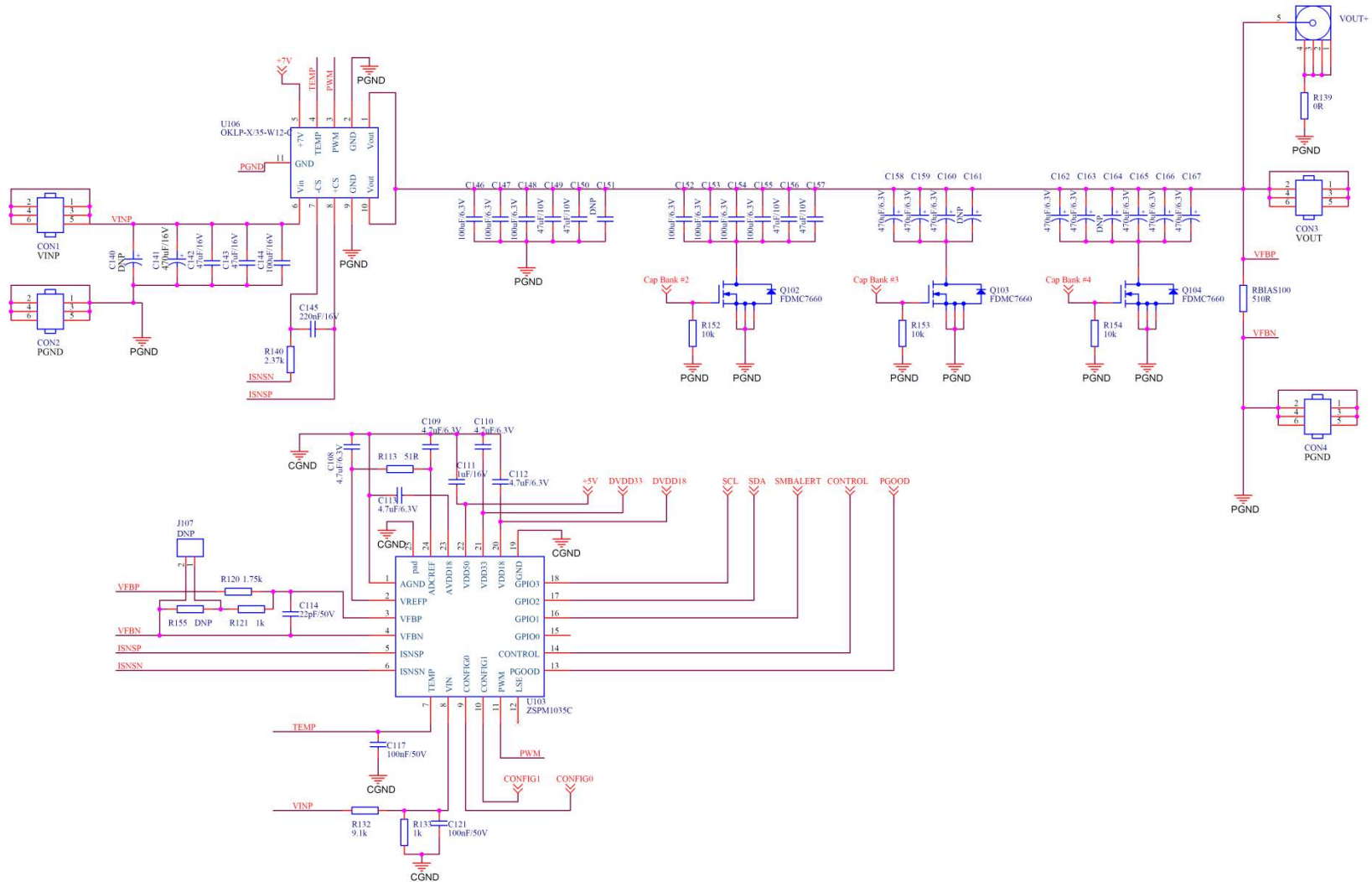

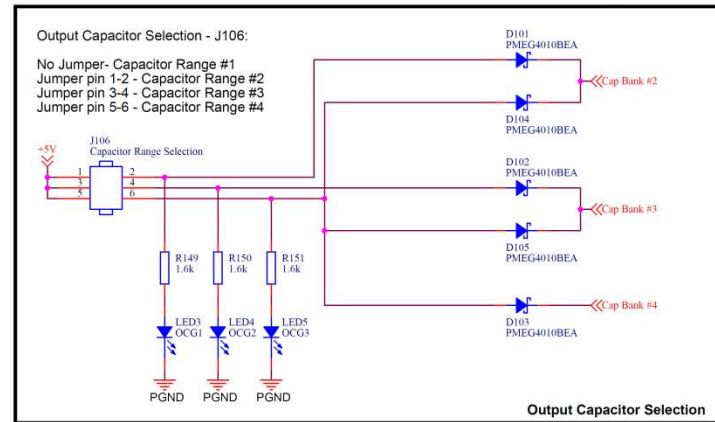
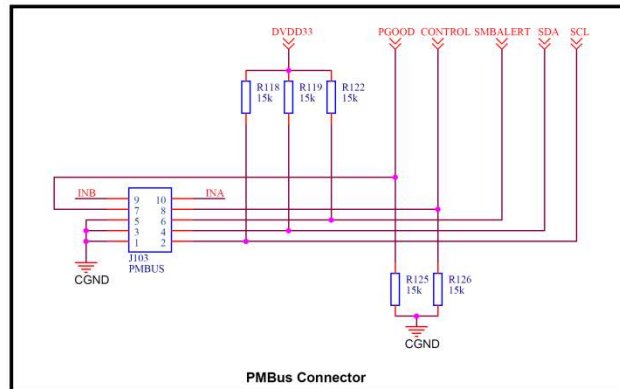
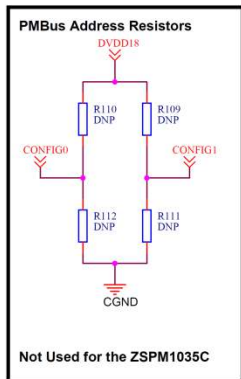
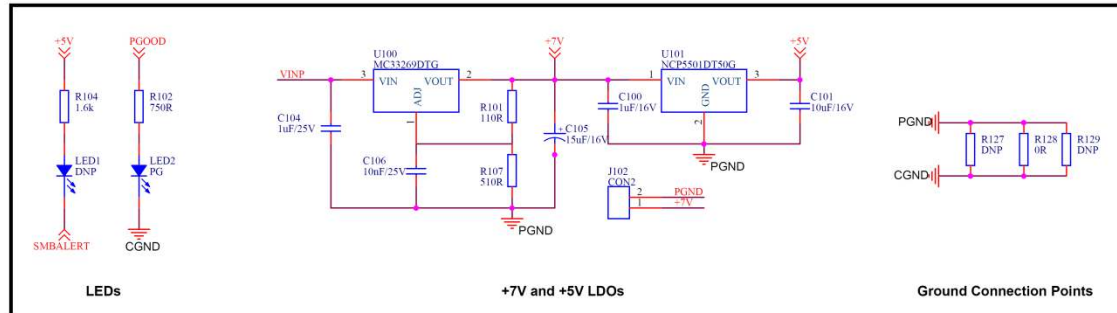
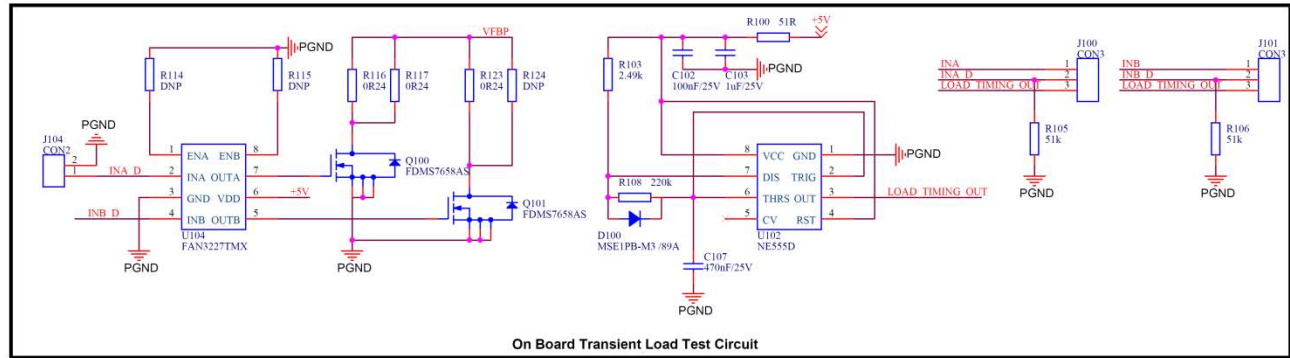
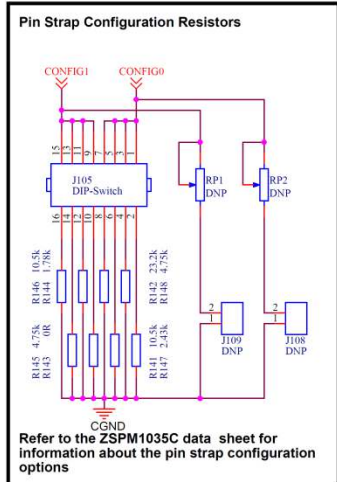

IMPORTANT NOTICE AND DISCLAIMER

RENESAS ELECTRONICS CORPORATION AND ITS SUBSIDIARIES (“RENESAS”) PROVIDES TECHNICAL SPECIFICATIONS AND RELIABILITY DATA (INCLUDING DATASHEETS), DESIGN RESOURCES (INCLUDING REFERENCE DESIGNS), APPLICATION OR OTHER DESIGN ADVICE, WEB TOOLS, SAFETY INFORMATION, AND OTHER RESOURCES “AS IS” AND WITH ALL FAULTS, AND DISCLAIMS ALL WARRANTIES, EXPRESS OR IMPLIED, INCLUDING, WITHOUT LIMITATION, ANY IMPLIED WARRANTIES OF MERCHANTABILITY, FITNESS FOR A PARTICULAR PURPOSE, OR NON-INFRINGEMENT OF THIRD PARTY INTELLECTUAL PROPERTY RIGHTS.

These resources are intended for developers skilled in the art designing with Renesas products. You are solely responsible for (1) selecting the appropriate products for your application, (2) designing, validating, and testing your application, and (3) ensuring your application meets applicable standards, and any other safety, security, or other requirements. These resources are subject to change without notice. Renesas grants you permission to use these resources only for development of an application that uses Renesas products. Other reproduction or use of these resources is strictly prohibited. No license is granted to any other Renesas intellectual property or to any third party intellectual property. Renesas disclaims responsibility for, and you will fully indemnify Renesas and its representatives against, any claims, damages, costs, losses, or liabilities arising out of your use of these resources. Renesas' products are provided only subject to Renesas' Terms and Conditions of Sale or other applicable terms agreed to in writing. No use of any Renesas resources expands or otherwise alters any applicable warranties or warranty disclaimers for these products.

(Disclaimer Rev.1.0 Mar 2020)

Corporate Headquarters

TOYOSU FORESIA, 3-2-24 Toyosu,
Koto-ku, Tokyo 135-0061, Japan
www.renesas.com

Contact Information

For further information on a product, technology, the most up-to-date version of a document, or your nearest sales office, please visit:
www.renesas.com/contact/

Trademarks

Renesas and the Renesas logo are trademarks of Renesas Electronics Corporation. All trademarks and registered trademarks are the property of their respective owners.