



LEOPARD IMAGING INC

Rev. 1.1

# LI-IMX185-MIPI-M12 Data Sheet

## Key Features

- Sony Diagonal 8.58mm Type 1/1.9 CMOS Image Sensor IMX185LQJ
- Active pixels: 1937H x 1217V
- Pixel size: 3.75  $\mu\text{m}$  x 3.75  $\mu\text{m}$
- Color sensor
- Interface: MIPI output
- Support M12 lens
- Module Size: 38mm x 38mm
- Weight: 12 g
- Part#: **LI-IMX185-MIPI-M12**



## Lens Spec

- Model: SYD1201A
- Focal length: 3.7 mm
- Aperture, F/#: 2.8 +/- 5%
- Built in 650nm IR cut filter
- FOV (D/H/V): 102° / 92° / 60°
- TV Distortion: -1.0 %
- Mount: M12 x P0.5



## Dimensions

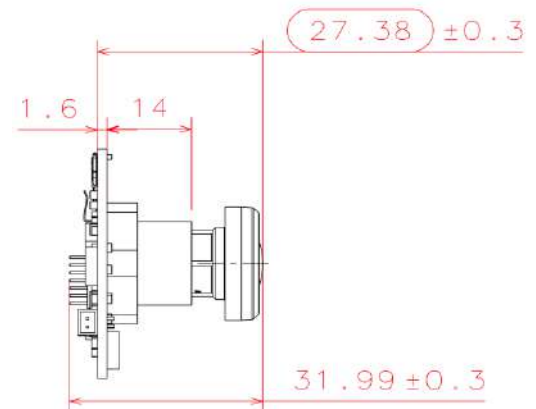
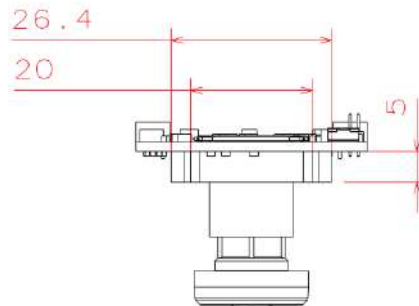
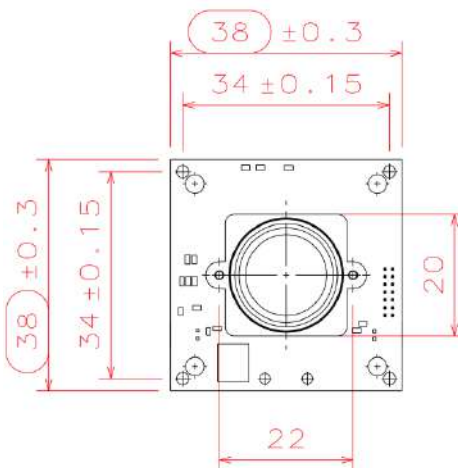

Leopard Imaging Inc.

1130 Cadillac Ct., Milpitas, CA 95035, USA  
 Phone: +1-408-263-0988  
 Fax: +1-408-217-1960  
 Email: sales@leopardimaging.com  
 Website: www.leopardimaging.com

# Interfaces

## Interfaces

### Interface J4:

- Part#: 20525-030E-02C
- Number of Positions: 30
- Pitch: 0.4mm
- Mating I-PEX cable: FAW-1233-03 (300mm)

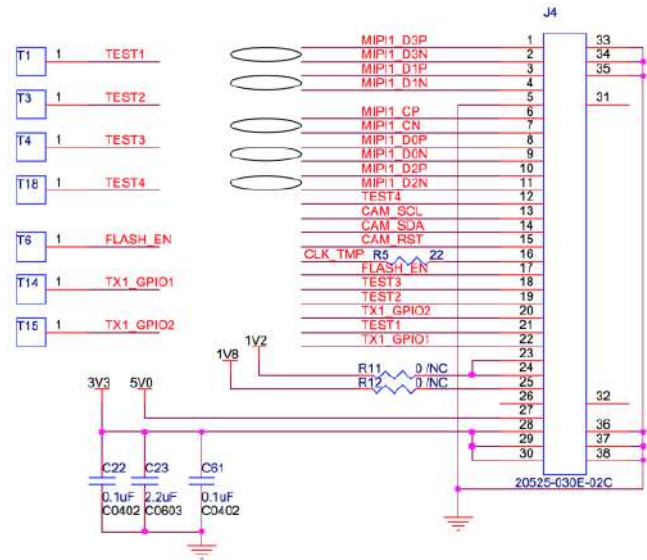

### Interface J3:

- Part#: 1734829-2
- Number of Positions: 2
- Pitch: 1.25mm

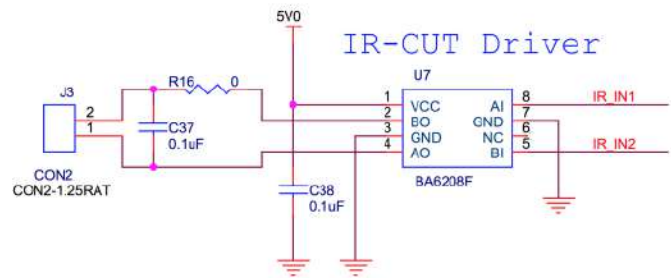

### Interface J5:

- Part#: 20021111-00014T4LF
- Number of Positions: 14
- Pitch: 1.27mm

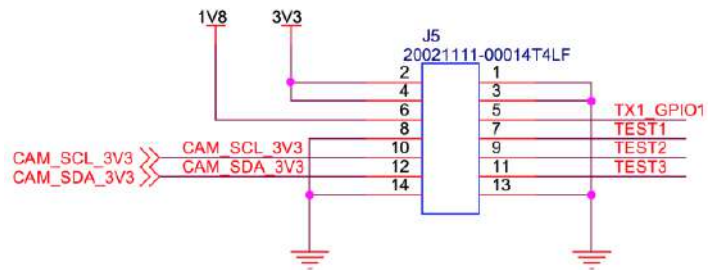

### Interface J6:

- Part#: 1734829-2
- Number of Positions: 2
- Pitch: 1.25mm

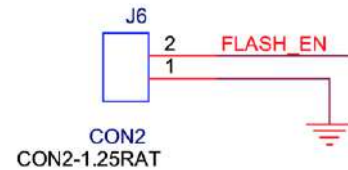

Leopard Imaging Inc.

1130 Cadillac Ct., Milpitas, CA 95035, USA  
 Phone: +1-408-263-0988  
 Fax: +1-408-217-1960  
 Email: sales@leopardimaging.com  
 Website: www.leopardimaging.com

## Absolute Maximum Ratings

Item	Symbol	Min.	Max.	Unit	Remarks
Supply voltage (analog 3.3 V)	AV <sub>DD</sub>	-0.3	4.0	V	
Supply voltage (digital 1.8 V)	OV <sub>DD</sub>	-0.3	3.3	V	
Supply voltage (digital 1.2 V)	DV <sub>DD</sub>	-0.3	2.0	V	
Input voltage	VI	-0.3	OV <sub>DD</sub> + 0.3	V	Not exceed 3.3 V
Output voltage	VO	-0.3	OV <sub>DD</sub> + 0.3	V	Not exceed 3.3 V
Guaranteed operating temperature	Topr	-30	+75	°C	
Storage guarantee temperature	Tstg	-40	+80	°C	
Performance guarantee temperature	Tspec	-10	+60	°C	

## Recommended Operating Conditions

Item	Symbol	Min.	Typ.	Max.	Unit
Supply voltage (analog 3.3 V)	AV <sub>DD</sub>	3.15	3.3	3.45	V
Supply voltage (digital 1.8 V)	OV <sub>DD</sub>	1.7	1.8	1.9	V
Supply voltage (digital 1.2 V)	DV <sub>DD</sub>	1.1	1.2	1.3	V

## Spectral Sensitivity Characteristics

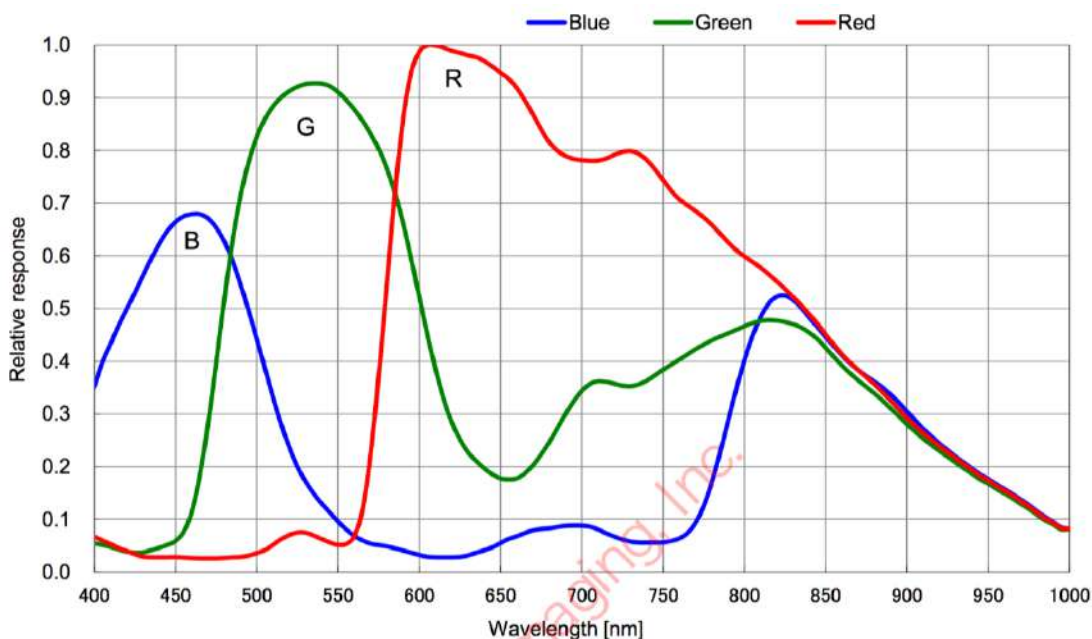

## DC Characteristics

Item	Pins	Symbol	Conditions	Min.	Typ.	Max.	Unit
Supply voltage	Analog	V <sub>DDHx</sub>	AV <sub>DD</sub>	3.15	3.30	3.45	V
	Digital	V <sub>DDMx</sub>	OV <sub>DD</sub>	1.70	1.80	1.90	V
	Digital	V <sub>DDLx</sub>	DV <sub>DD</sub>	1.10	1.20	1.30	V
Digital input voltage	XHS XVS XCLR INCK XMASTER OMODE SCK/SCL SDI/SDA XCE	VIH	XVS/XHS in slave mode	0.8 × OV <sub>DD</sub>	—	—	V
		VIL		—	—	0.2 × OV <sub>DD</sub>	V
Digital output voltage	DOP [11:0] DOM [11:0] DCKP DCKM	VCM	Low voltage LVDS	—	OV <sub>DD</sub> /2	—	V
		VOD	Low voltage LVDS (Termination resistance 100 Ω)	100	150	200	mV
	XHS XVS SDO	VOH	XVS/XHS in master mode	OV <sub>DD</sub> -0.4	—	—	V
		VOL		—	—	0.4	V

## Power Consumption

Item	Pins	Symbol	Typ.		Max.		Unit
			Standard luminous intensity	Saturated luminous intensity	Standard luminous intensity	Saturated luminous intensity	
Operating current CSI-2 serial output 4 Lane 12 bit, 60 frame/s 1080p-HD mode	V <sub>DDH</sub>	IAV <sub>DD</sub>	88	88	113	113	mA
	V <sub>DDM</sub>	IOV <sub>DD</sub>	2	2	4	4	mA
	V <sub>DDL</sub>	IDV <sub>DD</sub>	110	130	150	190	mA
Standby current	V <sub>DDH</sub>	IAV <sub>DD_STB</sub>	—	—	0.2		mA
	V <sub>DDM</sub>	IOV <sub>DD_STB</sub>	—	—	0.1		mA
	V <sub>DDL</sub>	IDV <sub>DD_STB</sub>	—	—	7.0		mA

Operating current:

(Typical value condition) : Supply voltage 3.3 V / 1.8 V / 1.2 V, T<sub>j</sub> = 25 °C

(Maximum value condition) : Supply voltage 3.45 V / 1.9 V / 1.3 V, worst state of internal circuit operating current consumption, T<sub>j</sub> = 60 °C

Standby (Maximum value condition) : Supply voltage 3.45 V / 1.9 V / 1.3 V, T<sub>j</sub> = 60 °C, INCK = 0 V

Standard luminous intensity: luminous intensity at standard imaging condition I

Saturated luminous intensity: luminous intensity when the sensor is saturated.





## AC Specification

### INCK

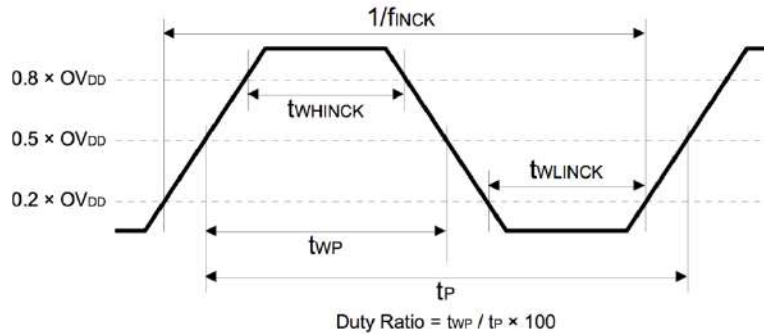

Item	Symbol	Min.	Typ.	Max.	Unit	Remarks
INCK clock frequency	$f_{INCK}$	$f_{INCK} \times 0.96$	$f_{INCK}$	$f_{INCK} \times 1.02$	MHz	$f_{INCK} = 27 \text{ MHz}, 54 \text{ MHz}, 37.125 \text{ MHz}, 74.25 \text{ MHz}$
INCK Low level width	$t_{WLINCK}$	4	—	—	ns	$f_{INCK} = 27 \text{ MHz}, 54 \text{ MHz}, 37.125 \text{ MHz}, 74.25 \text{ MHz}$
INCK High level width	$t_{WHINCK}$	4	—	—	ns	$f_{INCK} = 27 \text{ MHz}, 54 \text{ MHz}, 37.125 \text{ MHz}, 74.25 \text{ MHz}$
INCK clock duty	—	45.0	50.0	55.0	%	Define with $0.5 \times OV_{DD}$

\*The INCK fluctuation affects the frame rate.

### XHS, XVS Input Characteristics In Slave Mode (XMASTER pin = High)

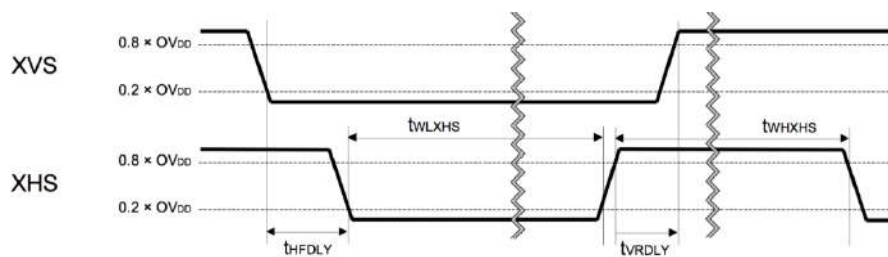

Item	Symbol	Min.	Typ.	Max.	Unit	Remarks
XHS Low level pulse width	$t_{WLXHS}$	$4 / f_{INCK}$	—	—	ns	
XHS High level pulse width	$t_{WHXHS}$	$4 / f_{INCK}$	—	—	ns	
XVS-XHS fall width	$t_{HFDLY}$	$1 / f_{INCK}$	—	—	ns	
XHS-XVS rise width	$t_{VRDLY}$	$1 / f_{INCK}$	—	—	ns	



Leopard Imaging Inc.

1130 Cadillac Ct., Milpitas, CA 95035, USA  
 Phone: +1-408-263-0988  
 Fax: +1-408-217-1960  
 Email: sales@leopardimaging.com  
 Website: www.leopardimaging.com

# I<sup>2</sup>C Communication

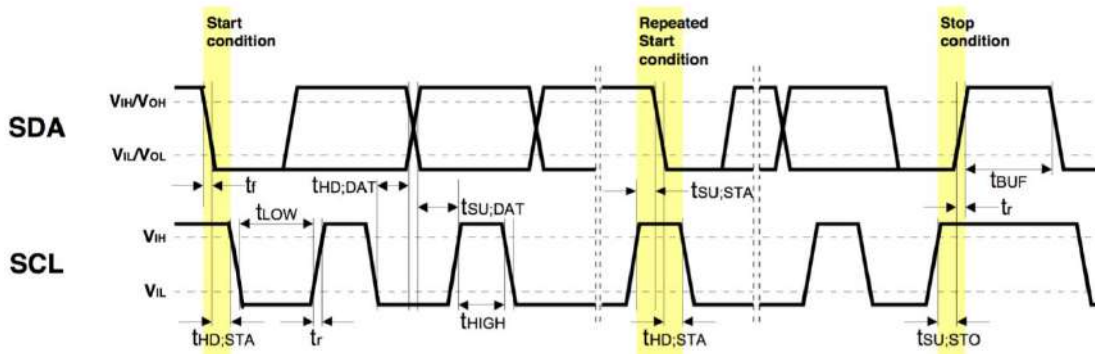

## I<sup>2</sup>C Specification

Item	Symbol	Min.	Typ.	Max.	Unit	Remarks
Low level input voltage	V <sub>IL</sub>	-0.3	—	0.3 × OV <sub>DD</sub>	V	
High level input voltage	V <sub>IH</sub>	0.7 × OV <sub>DD</sub>	—	1.9	V	
Low level output voltage	V <sub>OL</sub>	0	—	0.2 × OV <sub>DD</sub>	V	OV <sub>DD</sub> < 2 V, Sink 3 mA
High level output voltage	V <sub>OH</sub>	0.8 × OV <sub>DD</sub>	—	—	V	
Output fall time	t <sub>of</sub>	—	—	250	ns	Load 10 pF – 400 pF, 0.7 × OV <sub>DD</sub> – 0.3 × OV <sub>DD</sub>
Input current	i <sub>i</sub>	-10	—	10	μA	0.1 × OV <sub>DD</sub> – 0.9 × OV <sub>DD</sub>
Capacitance for SCK (/SCL), SDI (/SDA)	C <sub>i</sub>	—	—	10	pF	

## I<sup>2</sup>C AC Characteristics

Item	Symbol	Min.	Typ.	Max.	Unit
SCL clock frequency	f <sub>SCL</sub>	0	—	400	kHz
Hold time (Start Condition)	t <sub>HD,STA</sub>	0.6	—	—	μs
Low period of the SCL clock	t <sub>LOW</sub>	1.3	—	—	μs
High period of the SCL clock	t <sub>HIGH</sub>	0.6	—	—	μs
Set-up time (Repeated Start Condition)	t <sub>SUSTA</sub>	0.6	—	—	μs
Data hold time	t <sub>HDDAT</sub>	0	—	0.9	μs
Data set-up time	t <sub>SUDAT</sub>	100	—	—	ns
Rise time of both SDA and SCL signals	t <sub>R</sub>	—	—	300	ns
Fall time of both SDA and SCL signals	t <sub>F</sub>	—	—	300	ns
Set-up time (Stop Condition)	t <sub>SUSTO</sub>	0.6	—	—	μs
Bus free time between a Stop and Start Condition	t <sub>BUF</sub>	1.3	—	—	μs



# Power-on Sequence

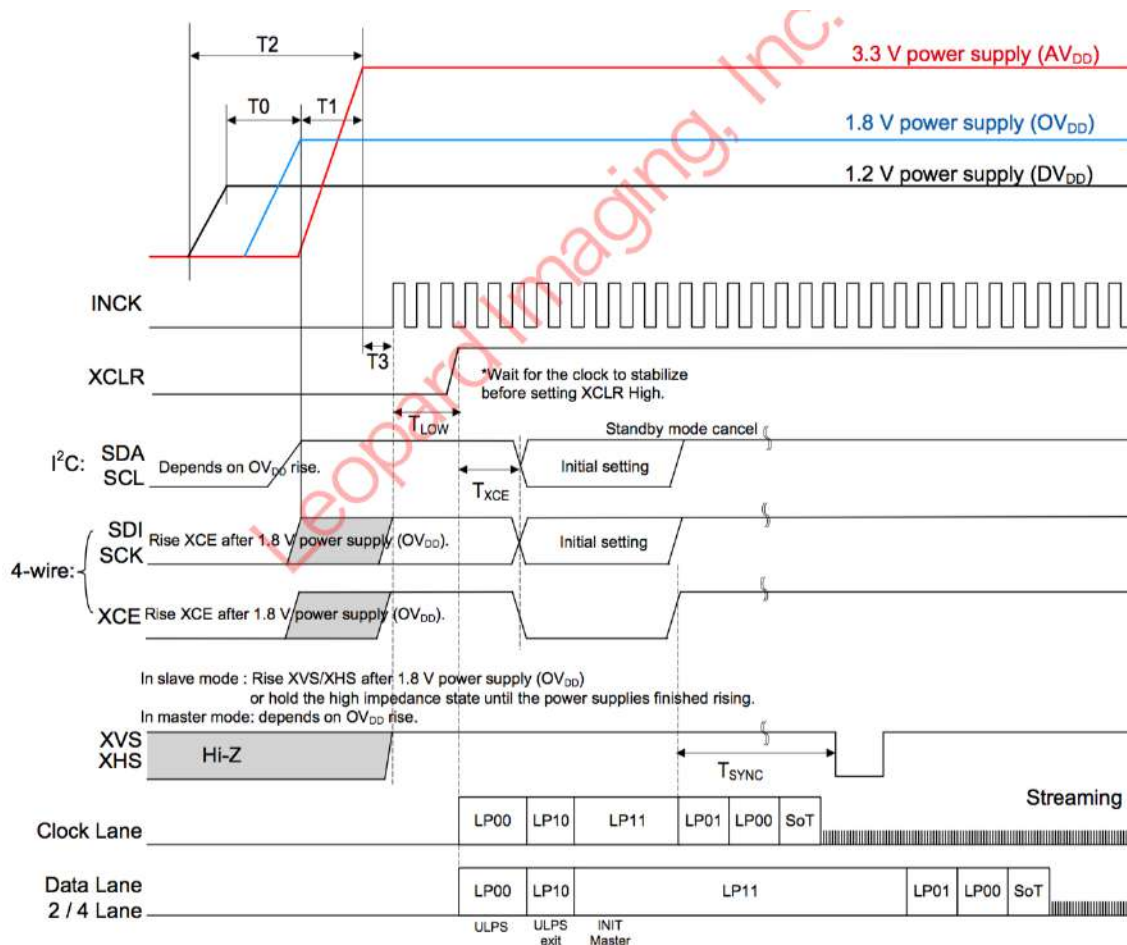

Item	Symbol	Min.	Max.	Unit
1.2 V power supply rising → 1.8 V power supply rising	T <sub>0</sub>	0	—	ns
1.8 V power supply rising → 3.3 V power supply rising	T <sub>1</sub>	0	—	ns
Rising time of all power supply	T <sub>2</sub>	—	200	ms
All power supply rising → External input time of INCK	T <sub>3</sub>	0	—	ns
INCK active → Clear OFF	T <sub>LOW</sub>	500	—	ns
Clear OFF → Communication start	T <sub>XCE</sub>	20	—	μs
Standby OFF (communication) → External input XHS, XVS (slave mode only)	T <sub>SYNC</sub>	20	—	ms



# Power-off Sequence

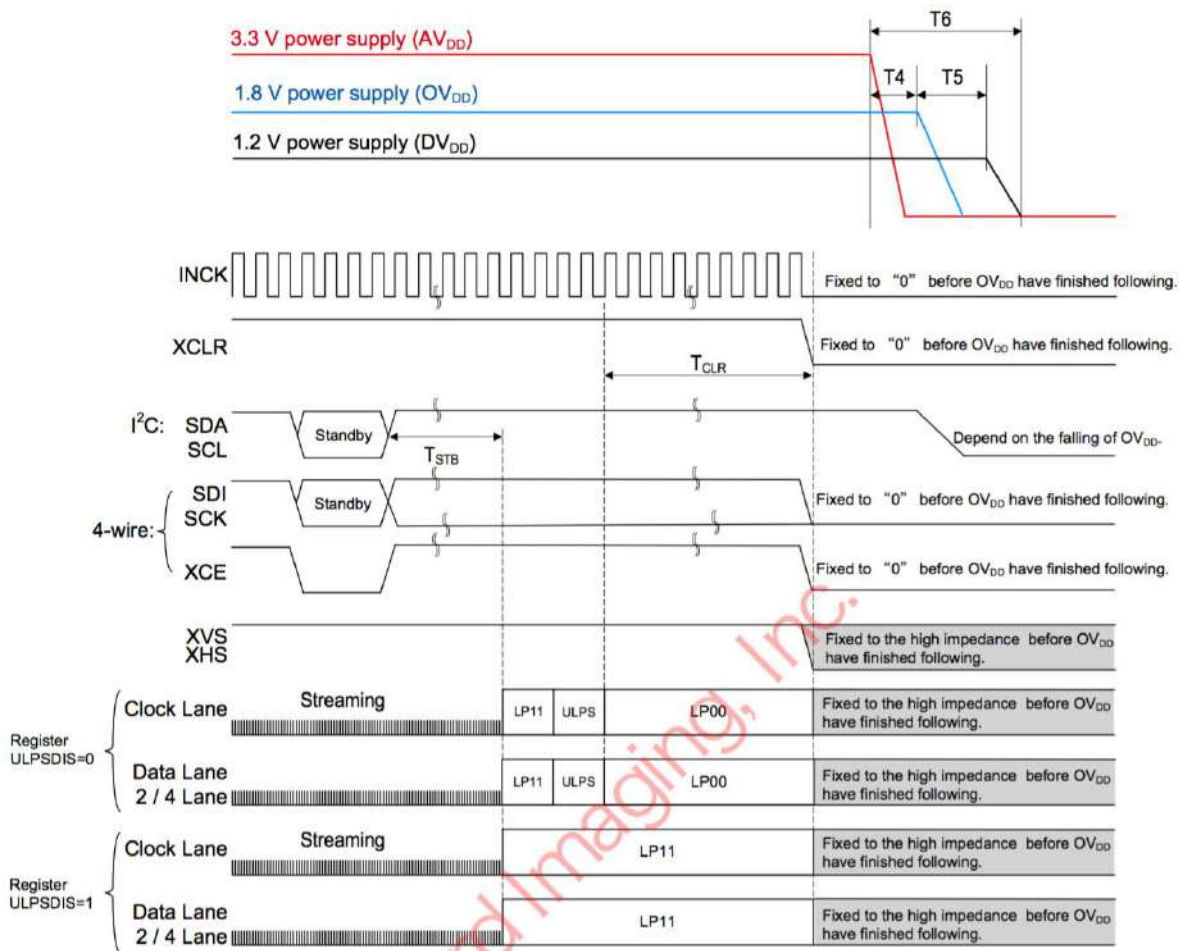

Item	Symbol	Min.	Max.	Unit
Standby ON (communication) → LP11 mode start	T <sub>STB</sub>	Until FE		—
LP00 → XCLR falling (ULPSDIS = 0)	T <sub>CLR</sub>	128	—	cycle
3.3 V power shut down → 1.8 V power shut down	T <sub>4</sub>	0	—	ns
1.8 V power shut down → 1.2 V power shut down	T <sub>5</sub>	0	—	ns
Shut down time of all power supply.	T <sub>6</sub>	—	200	ms

