

PI3DBS16222Q

3.3V 20Gbps 4-Channel 2x2 Exchange Switch
AEC-Q100 Grade, -40°C to 105°C

Features

- Four Differential Channel 2x2 Exchange Switch
- Data Rate 20Gbps Performance; Enable applications in PCI Express[®] 4.0, USB 4.0, USB 3.1 Gen 2, Thunderbolt™ 4, 10G BASE-KR
- Bidirectional Operation
- Low Bit-to-Bit Skew: 10ps
- Low Crosstalk:
 - -30dB @ 4.0GHz
 - -19dB @ 8.0GHz
 - -17dB @ 10GHz
- Low Insertion Loss:
 - -1.0dB @ 4.0GHz
 - -1.5dB @ 8.0GHz
 - -2.0dB @ 10 GHz
- V_{DD} Operating Range: 3.3V ± 10%
- AEC-Q100 Grade 2 Automotive Temperature Range: -40°C to 105°C
- Wettable QFN Design
- Totally Lead-Free & Fully RoHS Compliant (Notes 1 & 2)
- Halogen and Antimony Free. "Green" Device (Note 3)
- The DIODES™ PI3DBS16222Q is suitable for automotive applications requiring specific change control; this part is AEC-Q100 qualified, PPAP capable, and manufactured in IATF 16949 certified facilities.
<https://www.diodes.com/quality/product-definitions/>
- Packaging (Pb-free & Green):
 - 30-contact, TQFN (ZL30), 2.5mm × 4.5mm

Application(s)

- Applications up to 20 Gbps including PCIe 4.0, USB 3.2 Gen 2, 10GE, Thunderbolt 4, SAS 3.0, and SATA 3.0
- Automotive

Notes:

1. No purposely added lead. Fully EU Directive 2002/95/EC (RoHS), 2011/65/EU (RoHS 2) & 2015/863/EU (RoHS 3) compliant.
2. See <https://www.diodes.com/quality/lead-free/> for more information about Diodes Incorporated's definitions of Halogen- and Antimony-free, "Green" and Lead-free.
3. Halogen- and Antimony-free "Green" products are defined as those which contain <900ppm bromine, <900ppm chlorine (<1500ppm total Br + Cl) and <1000ppm antimony compounds.

DIODES is a trademark of Diodes Incorporated in the United States and other countries.

The Diodes logo is a registered trademark of Diodes Incorporated in the United States and other countries.

PCI Express[®] and PCIe[®] are trademarks or registered trademarks and/or service marks of PCI-SIG Corporation.

Description

The PI3DBS16222Q is an automotive-qualified differential exchange switch featuring pass-through pinout. It supports 2x2 exchange switch operating at 20Gbps, and enables applications in PCI Express 4.0, USB 4.0, USB 3.1 Gen 2, Thunderbolt 4, 10G BASE-KR.

When the select control input is low, Port A connects to port B, and port C connects to port D for an eight-channel differential pass-through. When the select control input is high, Port A connects to port D, and port B connects to port C.

Block Diagram

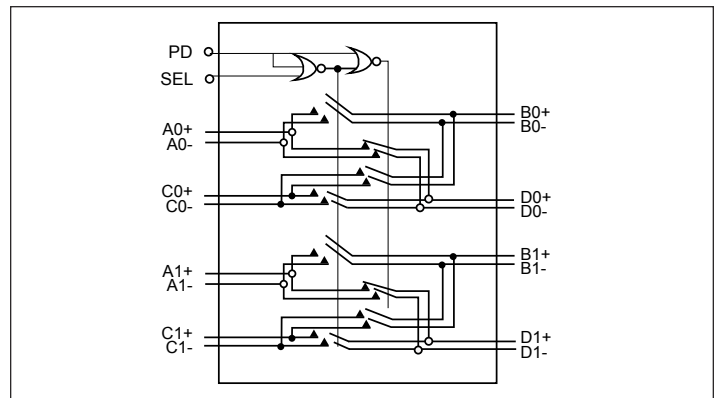

Ordering Information

Part Number	Package	Description
PI3DBS16222Q2ZLEX	ZL	30-contact, Thin Fine Pitch Quad Flat No Lead Package (TQFN)

Notes:

- Q = Automotive Compliant
- 2 = AEC-Q100 Grade Level
- E = Pb-free and Green
- X suffix = Tape/Reel