

LOADING PATTERN MATING SIDE

f	0	0	0	0	0	0	0	0	0	0
e	6	4	4	4	4	4	5	5	4	6
d	6	4	4	4	4	4	5	5	4	6
c	6	4	4	4	4	4	5	5	4	6
b	5	4	4	4	4	4	5	5	4	5
a	6	4	4	4	4	4	5	5	4	6
z	0	0	0	0	0	0	0	0	0	0
POS	01				05				10	

LOADED CONNECTOR ASSEMBLY
(FOR EXAMPLE)

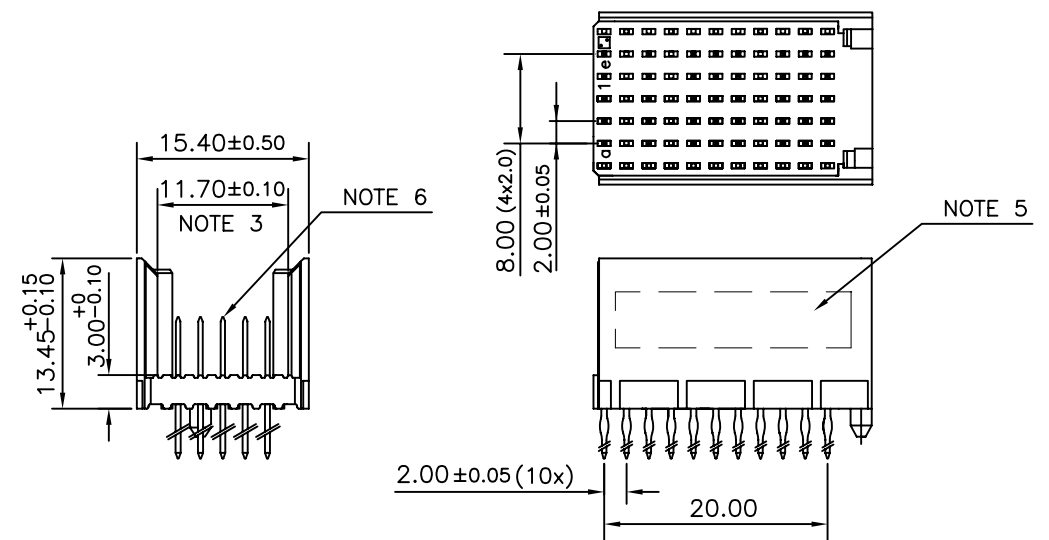

CONTACT OVERVIEW

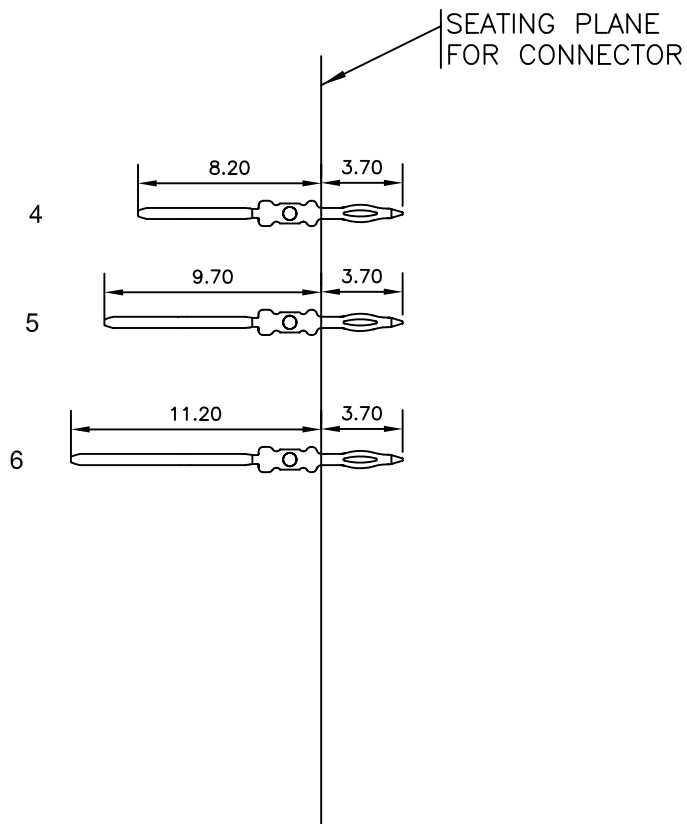

LAY-OUT P.C.B.-HOLE

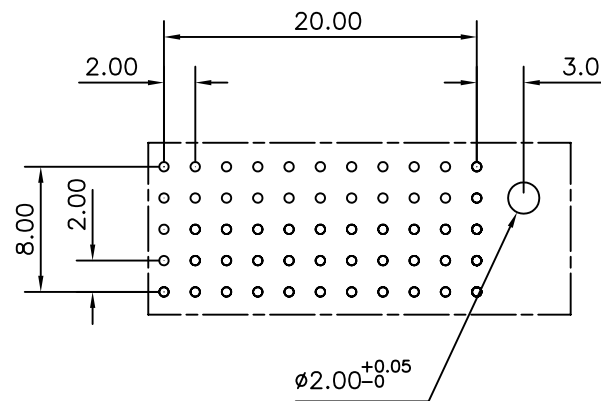

HM2P09PDM390 **LEAD FREE INDICATOR : LF = LEAD FREE (DIGIT 15 & 16)**

PLATING CODE (DIGIT 13 AND 14)
(REF DRW NO. BS,C , 201844 , 003)

NOTES

- THIS PRODUCT IS CSA APPROVED.
- THIS PRODUCT IS UL RECOGNIZED.
- MEASURED AT THE BOTTOM.
- MATERIAL CONTACT: PHOSPHORBRONZE
HOUSING: CREAM WHITE GLASS FILLED POLYESTER UL-94V0
- CONNECTOR PRINTED WITH P/N AND DATE CODE.
- FOR ACTUAL CONTACT LOADINGS, SEE LOADING PATTERN MATING SIDE.
- SHAPE OF CONNECTOR HOUSING CAN ALTER DEPENDING ON PRODUCTION LOCATION
- THIS PRODUCT (LF) MEETS EUROPEAN UNION DIRECTIVES AND OTHER COUNTRY REGULATIONS AS DESCRIBED IN GS-22-008
- FOR RECOMMENDED PTH DIMENSIONS REFER DRAWING : BS, A , 201572 , 001

CATALOG NO: HM2P09PDM390----

mat'l. code SEE NOTE 4		surface ISO 1302		tolerance ISO 406 ISO 1101		projection 		product family MILLIPACS			
ltr	ecn no	dr	date	tolerances unless otherwise specified		MM		title			
A	109-0158	GT	2009-08-12	angles	linear	MM		MPACS 5+2R STR HDR PF CONN TYPE C			
				0°±1°		scale -					
				dr	GEORGE THOMAS	2009-08-12			dwg no		
				enr	ALEX BABU	2009-08-12			sheet 1 of 1		size
				chr	ALEX BABU	2009-08-12			BS, C ,203028, 881		A3
				appd	ALEX BABU	2009-08-12			type		Product Customer Drawing
sheet index	revision sheet	A	1								