

SATA/SAS

SATA/SAS Daughter Card

User Manual

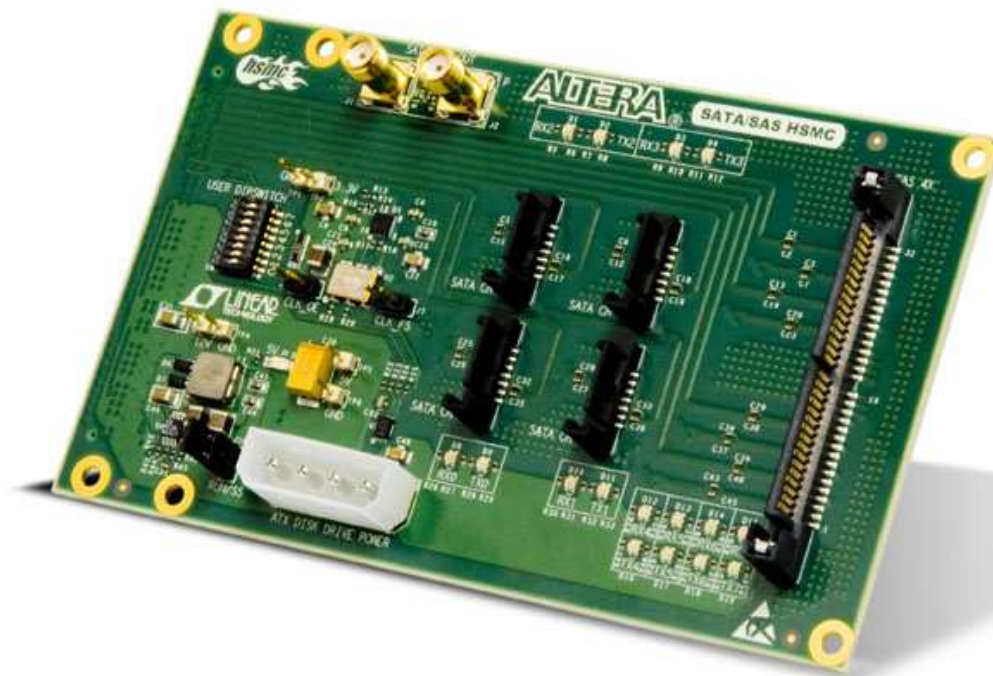

VERSION 1.0
March 1, 2010

terasic[®]
www.terasic.com

INTRODUCTION	1
1.1 FEATURES	1
1.2 ABOUT THE KIT	3
1.3 GETTING HELP	3
ARCHITECTURE	3
2.1 LAYOUT AND COMPONENTS	3
2.2 BLOCK DIAGRAM	7
BOARD COMPONENTS	8
3.1 HSMC EXPANSION CONNECTOR	8
3.2 I2C SERIAL EEPROM	16
3.3 SATA/SAS CLOCK	17
3.4 SATA/SAS SINGLE LANE CHANNEL	18
3.5 SATA/SAS 4 LANE CHANNEL	19
3.6 CONFIGURATION, STATUS AND SETUP ELEMENTS	20
3.4 ATX POWER	21
DEMONSTRATION	22
4.1 INTRODUCTION	22
4.2 SYSTEM REQUIREMENTS	23
4.3 SETUP THE DEMONSTRATION	24
4.4 DEMO OPERATION	27
APPENDIX	27
5.1 REVISION HISTORY	27
5.2 ALWAYS VISIT SATA WEBPAGE FOR NEW MAIN BOARD	27

The SATA/SAS daughter card is designed to provide SATA interface conversion for FPGA platforms that support SAS and SATA solutions based on the latest 40-nm technology through a High-Speed Mezzanine Connector (HSMC). It allows users to access storage devices through the SATA/SAS protocols on an FPGA specifically the Stratix IV GX, Stratix II GX, Arria II GX, and Cyclone IV GX devices. This card features 4 single channel SATA signal plug connectors, one 4 channel SATA/SAS connector, and one ATX style output power connector for hard drives. With the SATA interface conversion established on the HSMC interface, your FPGA system can bridge different protocols enabling the FPGA to be a system on chip (SOC), plus with the SATA/SAS IP core on the FPGA it can be used for functionality, specification-compliance, interoperability, and performance testing. The SATA/SAS daughter card is the ideal platform for SATA interface conversion ensuring an excellent way to develop SOC solutions for storage applications on the Altera's 40-nm FPGAs with integrated transceivers.

1.1 Features

Figure 1.1 shows the photo of the SATA/SAS card. The important functions of the card are listed below:

- HSMC interface
 - 8 high speed interfaces supporting SATA / SAS communications at 1.5Gbps, 3 Gbps and 6Gbps data rates
 - 6 out-of-band signals supported for the 4 lane connector
 - Dipswitch inputs on CMOS input section of HSMC
 - LED drive outputs for 16 bi-color LEDs (32 connections)
- SATA/SAS Single lane interface
 - Internal style vertical surface mount connectors
- SATA/SAS 4 lane interface
 - Internal style 32 pin vertical surface mount connector
- ATX power
 - Standard ATX 4 pin connector providing 1 Amp on both 12V and 5V power rails from host boards able to support current
- 8 Kbit I2C EEPROM
- Differential clocking for 150MHz and 300MHz reference clocks through the HSMC or SMA connectors

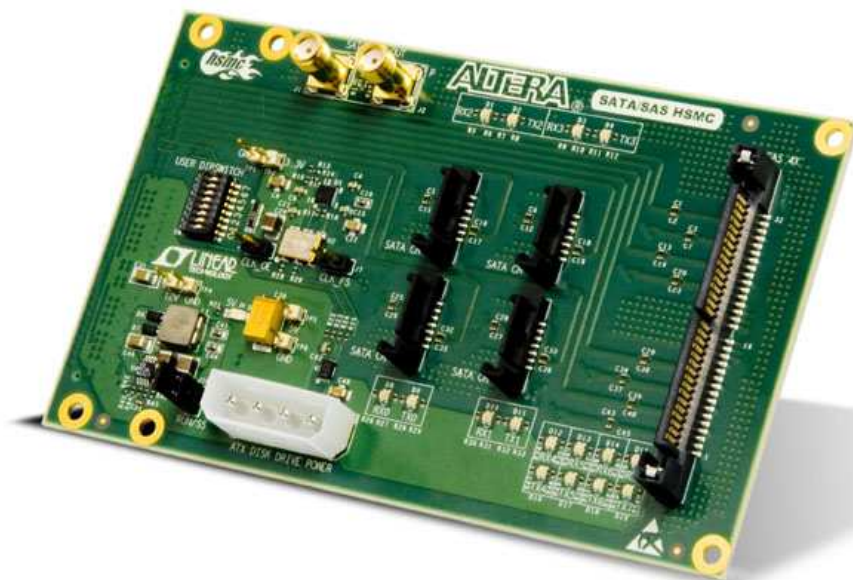

Figure 1.1. The picture of the SATA/SAS card

1.2 About the KIT

This section describes the package content

- SATA/SAS HSMC card x 1
- SATA **crossover** ribbon cable x 2
- System CD-ROM x 1

* The SATA **crossover** ribbon cable is only used for loopback testing purposes. Please do not attempt to connect SATA hard-disk using this cable.

The CD contains technical documents of the SATA/SAS card

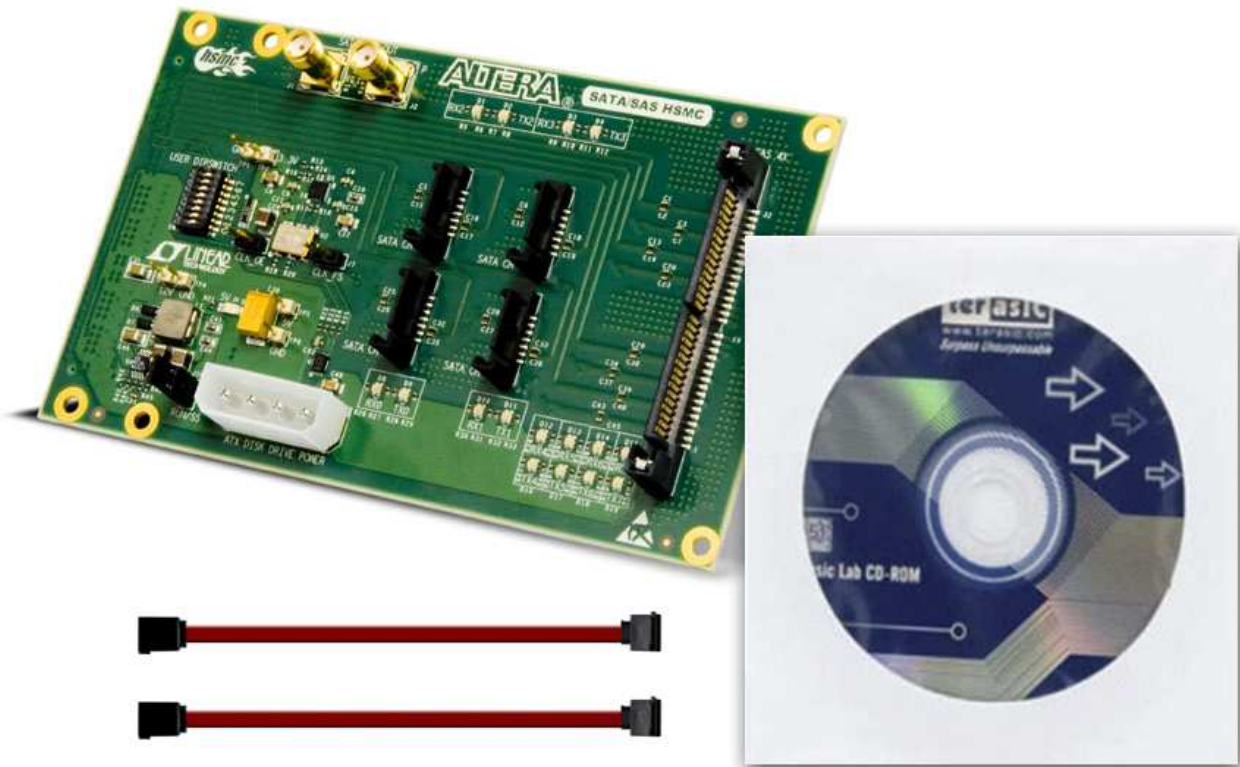

Figure 1.2 SATA/SAS card Package

1.3 Getting Help

Here are some places to get help if you encounter any problem:

- ✓ Email to support@terasinc.com
- ✓ Taiwan & China: +886-3-550-8800
- ✓ Korea : +82-2-512-7661
- ✓ Japan: +81-428-77-7000

2 Architecture

This chapter describes the architecture of the SATA/SAS card including block diagram and components.

2.1 Layout and Componets

The picture of the SATA/SAS card is shown in [Figure 2.1](#) and [Figure 2.2](#). It depicts the layout of the board and indicates the locations of the connectors and key components.

Architecture

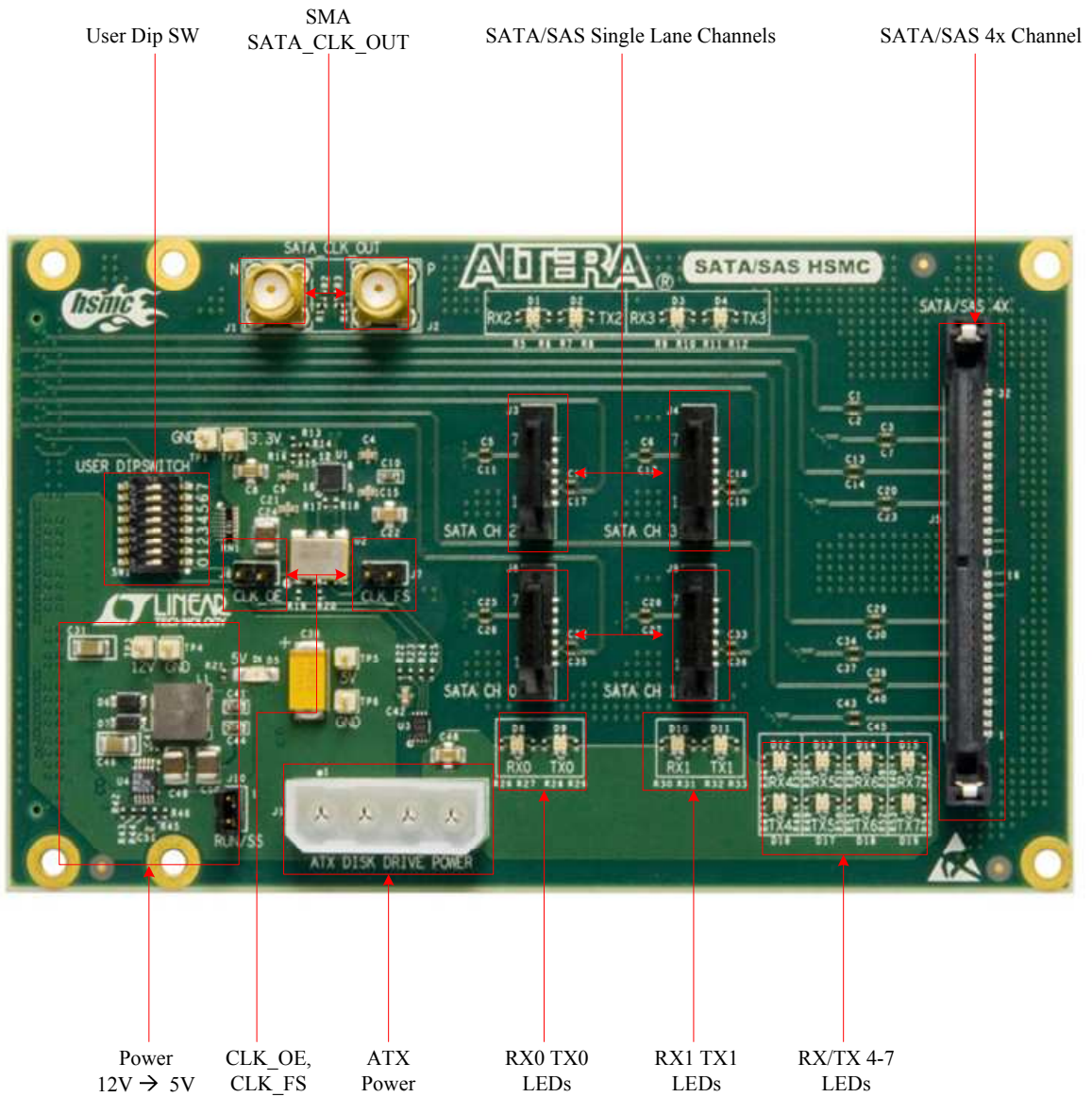

Figure 2.1 The SATA/SAS Card PCB and component diagram

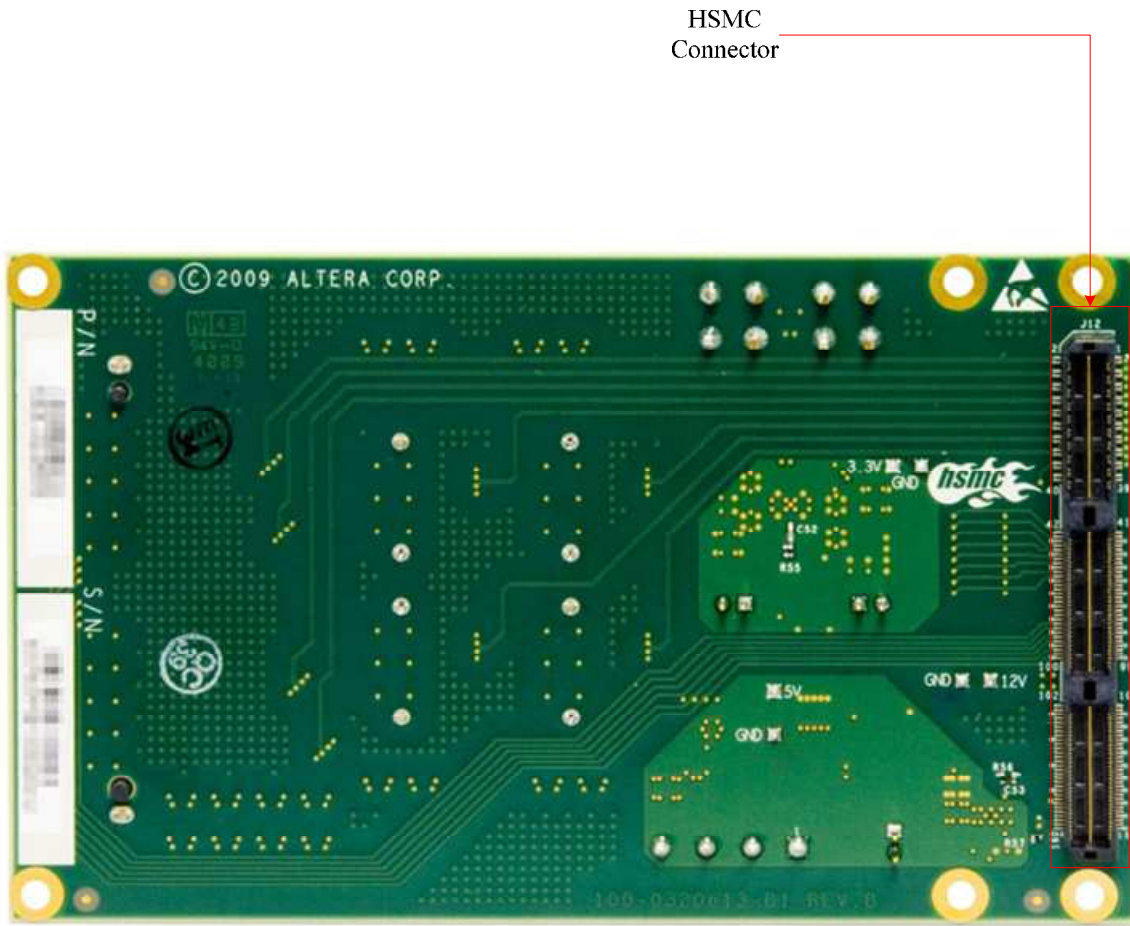

Figure 2.2 The SATA/SAS card back side – HSMC connector view

The following components are provided on the SATA/SAS card :

- HSMC Connector (J12)
- User Dip SW (SW1)
- SMA SATA_CLK_OUT (J1/J2)
- SATA/SAS Single Lane Channels (J3/J4/J8/J9)
- SATA/SAS 4x Channel (J5)
- ATX Power (J11)
- CLK_OE (J6), CLK_FS (J7)

2.2 Block Diagram

Figure 2.3 shows the block diagram of the SATA/SAS card.

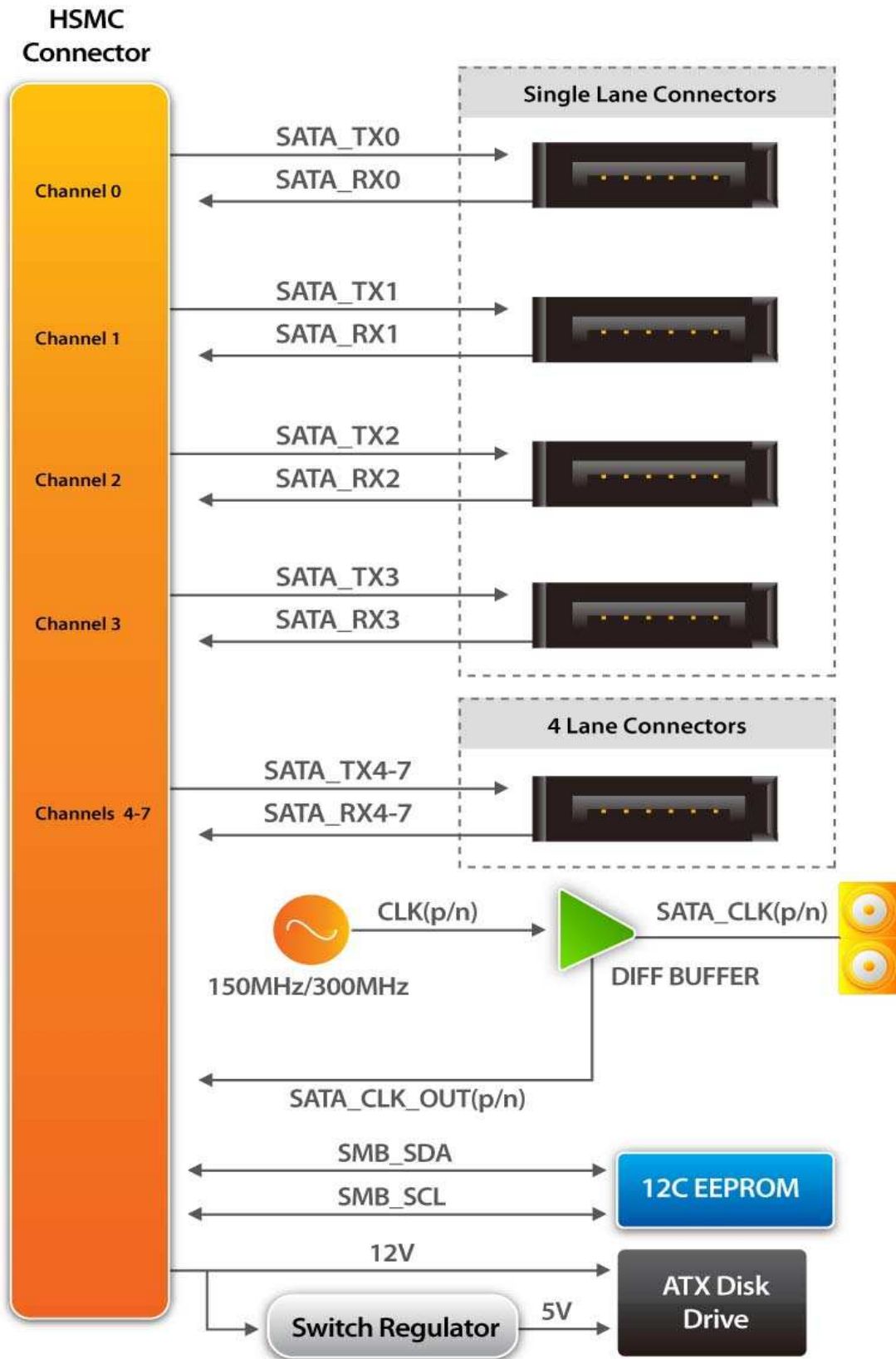

Figure 2.3. The block diagram of the SATA/SAS Card

This section will describe the detailed information of the components, connector interfaces, and the pin mappings on the SATA/SAS card.

3.1 HSMC Expansion Connector

This section describes the HSMC connector on the SATA/SAS card

The SATA/SAS card contains an Altera standard HSMC connector. All the other interfaces on the SATA/SAS card are connected to the HSMC connector. [Figure 3.1](#) shows the pin-outs of the HSMC connector and [Table 3.1](#) lists the description of each signals corresponding to the HSMC connector.

Board Components

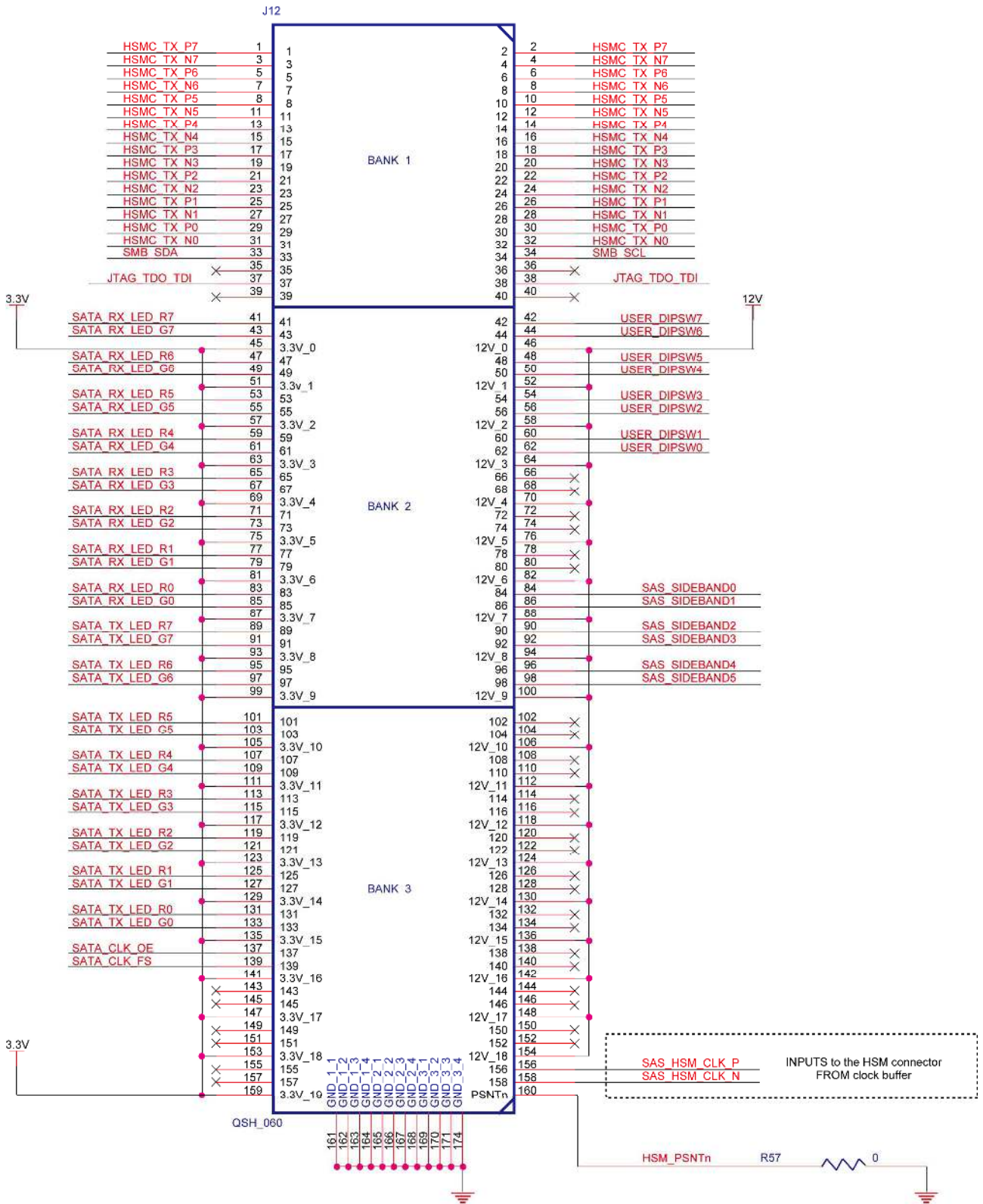

Figure 3.1 The pin-outs of the HSMC connector.

Board Components

Table 3.1 below lists the HSMC signal direction and description

Pin Numbers	Name	Direction (with respect to the FPGA board)	Description
1	HSM_TX_P7	Output	Differential transmit data output before DC blocking capacitor
2	HSM_RX_P7	Input	Differential transmit data input before DC blocking capacitor
3	HSM_TX_N7	Output	Differential transmit data output before DC blocking capacitor
4	HSM_RX_N7	Input	Differential transmit data input before DC blocking capacitor
5	HSM_TX_P6	Output	Differential transmit data output before DC blocking capacitor
6	HSM_RX_P6	Input	Differential transmit data input before DC blocking capacitor
7	HSM_TX_N6	Output	Differential transmit data output before DC blocking capacitor
8	HSM_RX_N6	Input	Differential transmit data input before DC blocking capacitor
9	HSM_TX_P5	Output	Differential transmit data output before DC blocking capacitor
10	HSM_RX_P5	Input	Differential transmit data input before DC blocking capacitor
11	HSM_TX_N5	Output	Differential transmit data output before DC blocking capacitor
12	HSM_RX_N5	Input	Differential transmit data input before DC blocking capacitor
13	HSM_TX_P4	Output	Differential transmit data output before DC blocking capacitor
14	HSM_RX_P4	Input	Differential transmit data input before DC blocking capacitor
15	HSM_TX_N4	Output	Differential transmit data output before DC blocking capacitor
16	HSM_RX_N4	Input	Differential transmit data input before DC blocking capacitor
17	HSM_TX_P3	Output	Differential transmit data output before DC blocking capacitor
18	HSM_RX_P3	Input	Differential transmit data input before DC blocking capacitor

Board Components

19	HSM_TX_N3	Output	Differential transmit data output before DC blocking capacitor
20	HSM_RX_N3	Input	Differential transmit data input before DC blocking capacitor
21	HSM_TX_P2	Output	Differential transmit data output before DC blocking capacitor
22	HSM_RX_P2	Input	Differential transmit data input before DC blocking capacitor
23	HSM_TX_N2	Output	Differential transmit data output before DC blocking capacitor
24	HSM_RX_N2	Input	Differential transmit data input before DC blocking capacitor
25	HSM_TX_P1	Output	Differential transmit data output before DC blocking capacitor
26	HSM_RX_P1	Input	Differential transmit data input before DC blocking capacitor
27	HSM_TX_N1	Output	Differential transmit data output before DC blocking capacitor
28	HSM_RX_N1	Input	Differential transmit data input before DC blocking capacitor
29	HSM_TX_P0	Output	Differential transmit data output before DC blocking capacitor
30	HSM_RX_P0	Input	Differential transmit data input before DC blocking capacitor
31	HSM_TX_N0	Output	Differential transmit data output before DC blocking capacitor
32	HSM_RX_N0	Input	Differential transmit data input before DC blocking capacitor
33	SMB_SDA	Inout	I2C EEPROM serial address/data I/O
34	SMB_SCL	Inout	I2C EEPROM serial clock
35	-	-	-
36	-	-	-
37	JTAG_TDO_TDI	Inout	JTAG
38	JTAG_TDO_TDI	Inout	JTAG
39	-	-	-
40	-	-	-
41	SATA_RX_LED_ R7	Output	Red LED signal

Board Components

42	USER_DIPSW7	Input	User control input from dipswitch
43	SATA_RX_LED_ G7	Output	Green LED signal
44	USER_DIPSW6	Input	User control input from dipswitch
45	3V3	Power	Power 3.3V
46	12V	Power	Power 12V
47	SATA_RX_LED_ R6	Output	Red LED signal
48	USER_DIPSW5	Input	User control input from dipswitch
49	SATA_RX_LED_ G6	Output	Green LED signal
50	USER_DIPSW4	Input	User control input from dipswitch
51	3V3	Power	Power 3.3V
52	12V	Power	Power 12V
53	SATA_RX_LED_ R5	Output	Red LED signal
54	USER_DIPSW3	Input	User control input from dipswitch
55	SATA_RX_LED_ G5	Output	Green LED signal
56	USER_DIPSW2	Input	User control input from dipswitch
57	3V3	Power	Power 3.3V
58	12V	Power	Power 12V
59	SATA_RX_LED_ R4	Output	Red LED signal
60	USER_DIPSW1	Input	User control input from dipswitch
61	SATA_RX_LED_ G4	Output	Green LED signal
62	USER_DIPSW0	Input	User control input from dipswitch
63	3V3	Power	Power 3.3V
64	12V	Power	Power 12V
65	SATA_RX_LED_ R3	Output	Red LED signal
66	-	-	-
67	SATA_RX_LED_ G3	Output	Green LED signal
68	-	-	-
69	3V3	Power	Power 3.3V
70	12V	Power	Power 12V
71	SATA_RX_LED_ G3	Output	Red LED signal

Board Components

R2			
72	-	-	-
73	SATA_RX_LED_	Output	Green LED signal
G2			
74	-	-	-
75	3V3	Power	Power 3.3V
76	12V	Power	Power 12V
77	SATA_RX_LED_	Output	Red LED signal
R1			
78	-	-	-
79	SATA_RX_LED_	Output	Green LED signal
G1			
80	-	-	-
81	3V3	Power	Power 3.3V
82	12V	Power	Power 12V
83	SATA_RX_LED_	Output	Red LED signal
R0			
84	SAS_SIDE BAND 0	Inout	4 lane SATA/SAS sideband signal
85	SATA_RX_LED_	Output	Green LED signal
G0			
86	SAS_SIDE BAND 1	Inout	4 lane SATA/SAS sideband signal
87	3V3	Power	Power 3.3V
88	12V	Power	Power 12V
89	SATA_TX_LED_	Output	Red LED signal
R7			
90	SAS_SIDE BAND 2	Inout	4 lane SATA/SAS sideband signal
91	SATA_TX_LED_	Output	Green LED signal
G7			
92	SAS_SIDE BAND 3	Inout	4 lane SATA/SAS sideband signal
93	3V3	Power	Power 3.3V
94	12V	Power	Power 12V
95	SATA_TX_LED_	Output	Red LED signal
R6			
96	SAS_SIDE BAND 4	Inout	4 lane SATA/SAS sideband signal

Board Components

97	SATA_TX_LED_ G6	Output	Green LED signal
98	SAS_SIDEHAND 5	Inout	4 lane SATA/SAS sideband signal
99	3V3	Power	Power 3.3V
100	12V	Power	Power 12V
101	SATA_TX_LED_ R5	Output	Red LED signal
102	-	-	-
103	SATA_TX_LED_ G5	Output	Green LED signal
104	-	-	-
105	3V3	Power	Power 3.3V
106	12V	Power	Power 12V
107	SATA_TX_LED_ R4	Output	Red LED signal
108	-	-	-
109	SATA_TX_LED_ G4	Output	Green LED signal
110	-	-	-
111	3V3	Power	Power 3.3V
112	12V	Power	Power 12V
113	SATA_TX_LED_ R3	Output	Red LED signal
114	-	-	-
115	SATA_TX_LED_ G3	Output	Green LED signal
116	-	-	-
117	3V3	Power	Power 3.3V
118	12V	Power	Power 12V
119	SATA_TX_LED_ R2	Output	Red LED signal
120	-	-	-
121	SATA_TX_LED_ G2	Output	Green LED signal
122	-	-	-
123	3V3	Power	Power 3.3V
124	12V	Power	Power 12V
125	SATA_TX_LED_ G1	Output	Red LED signal

Board Components

R1			
126	-	-	-
127	SATA_TX_LED_	Output	Green LED signal
G1			
128	-	-	-
129	3V3	Power	Power 3.3V
130	12V	Power	Power 12V
131	SATA_TX_LED_	Output	Red LED signal
R0			
132	-	-	-
133	SATA_TX_LED_	Output	Green LED signal
G0			
134	-	-	-
135	3V3	Power	Power 3.3V
136	12V	Power	Power 12V
137	SATA_CLK_OE	Output	Oscillator clock output enable (Active High)
138	SATA_CLK_FS	Output	150MHz/300MHz oscillator frequency select
139	-	-	-
140	-	-	-
141	3V3	Power	Power 3.3V
142	12V	Power	Power 12V
143	-	-	-
144	-	-	-
145	-	-	-
146	-	-	-
147	3V3	Power	Power 3.3V
148	12V	Power	Power 12V
149	-	-	-
150	-	-	-
151	-	-	-
152	-	-	-
153	3V3	Power	Power 3.3V
154	12V	Power	Power 12V
155	-	-	-
156	SATA_HSM_CLK _P	Input	150MHz/300MHz differential clock
157	-	-	-

Board Components				
158	SATA_HSM_CLK _N	Input	150MHz/300MHz clock	differential
159	3V3	Power	Power 3.3V	
160	HSM_PSNTn	Power	Power Ground	

3.2 I2C Serial EEPROM

This section describes the I2C Serial EEPROM on the SATA/SAS card

The SATA/SAS card consists of an 8 Kbit EEPROM which is configured through a 2-wire serial interface. The device is organized as four blocks of 256 x 8-bit memory. The detailed pin description between the HSMC and EEPROM is shown below in [Figure 3.2](#).

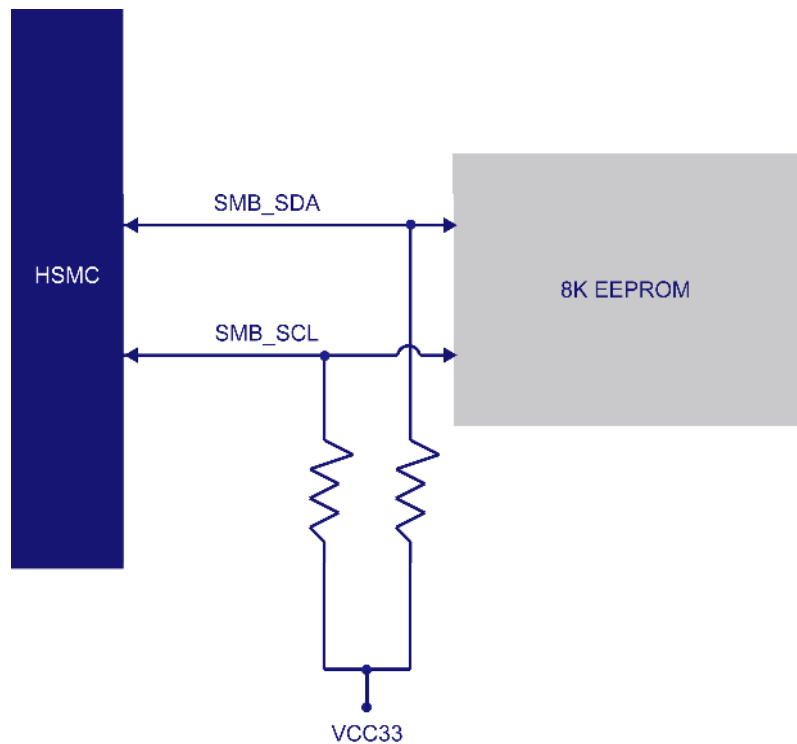

Figure 3.2 EEPROM connection to the HSMC connector

3.3 SATA/SAS Clock

This section describes clock circuitry on the SATA/SAS card

The on-board oscillator is to provide a clean low jitter reference clock at frequencies of 150MHz and 300MHz by toggling the frequency select pin (FS) for use in the high-speed SERDES TX and RX, while the output enable (OE) of the oscillator will tri-state the output pins. The oscillator output is driven to a differential clock buffer to provide two identical differential clock outputs to the HSMC and SMA connectors. [Figure 3.3](#) depicts the connection made on the oscillator clocks and SMA connectors.

Board Reference	Signal Name	Description
J6	CLK_OE	Jumper DNI – clock output enabled (default), Jumper Installed – clock output disabled (outputs tristated)
J7	CLK_FS	Jumper Installed – 150MHz clock selected (default), Jumper DNI – 300MHz clock selected

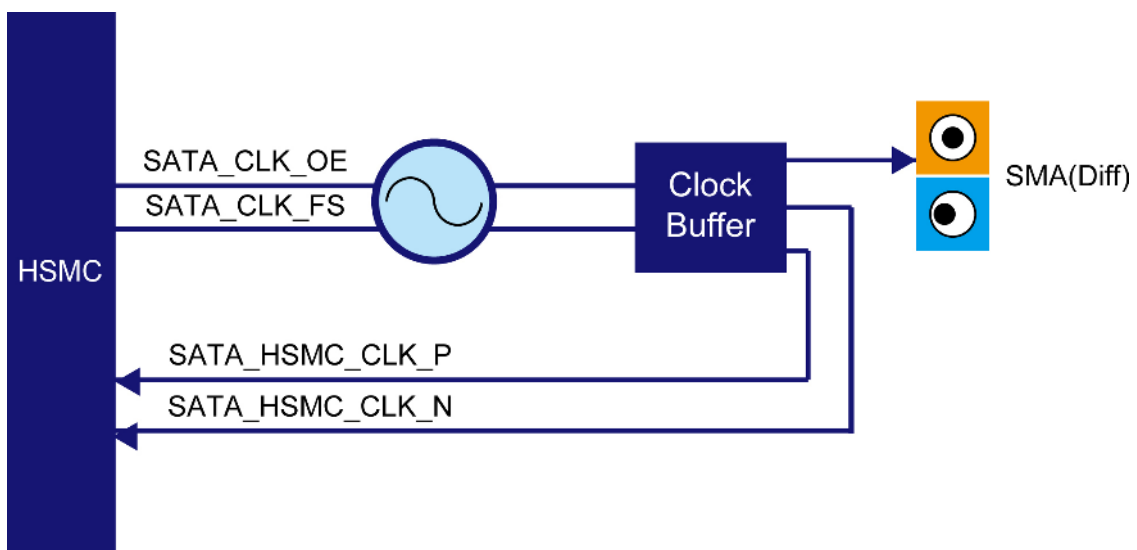

Figure 3.3 Clock connection on the SATA/SAS daughter card

3.4 SATA/SAS Single Lane Channel

This section describes SATA/SAS single lane channel on the SATA/SAS card

There are 4 single channel SATA single channel links which are facilitated on the SATA/SAS card using the passive connection from the high-speed serial link from the HSMC connector to the 7-pin SATA signal plugs. The routing between the two connectors is 100 Ohm differential impedance route with DC blocking capacitors in the middle of the channel. [Figure 3.4](#) depicts a block diagram of the SATA/SAS single lane channel.

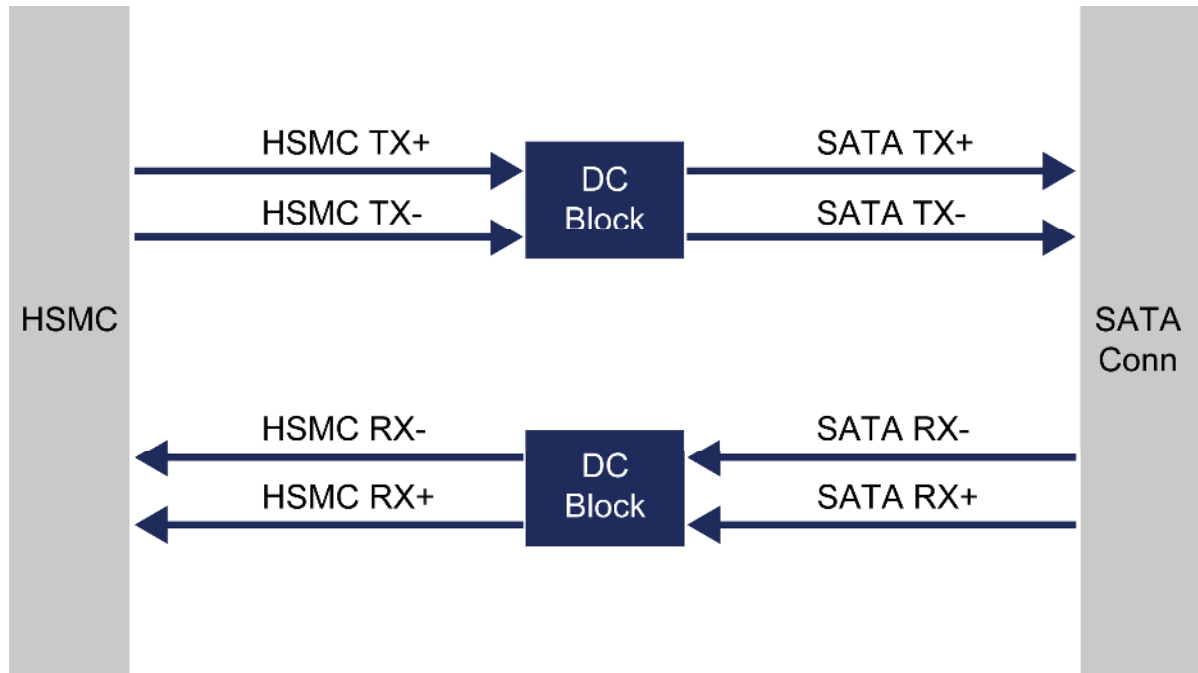

Figure 3.4 Block diagram of the SATA/SAS single lane channel

3.5 SATA/SAS 4 Lane Channel

This section describes SATA/SAS 4 lane channel on the SATA/SAS card

A 32 pins signal connector is used for SATA/SAS quad channel link. The connector contains 16 high-speed differential signals for SATA/SAS communications protocol. There are 10 pins used for signal ground and 6 pins for sideband signals. [Figure 3.5](#) shows the block diagram of the SATA/SAS 4 lane channel.

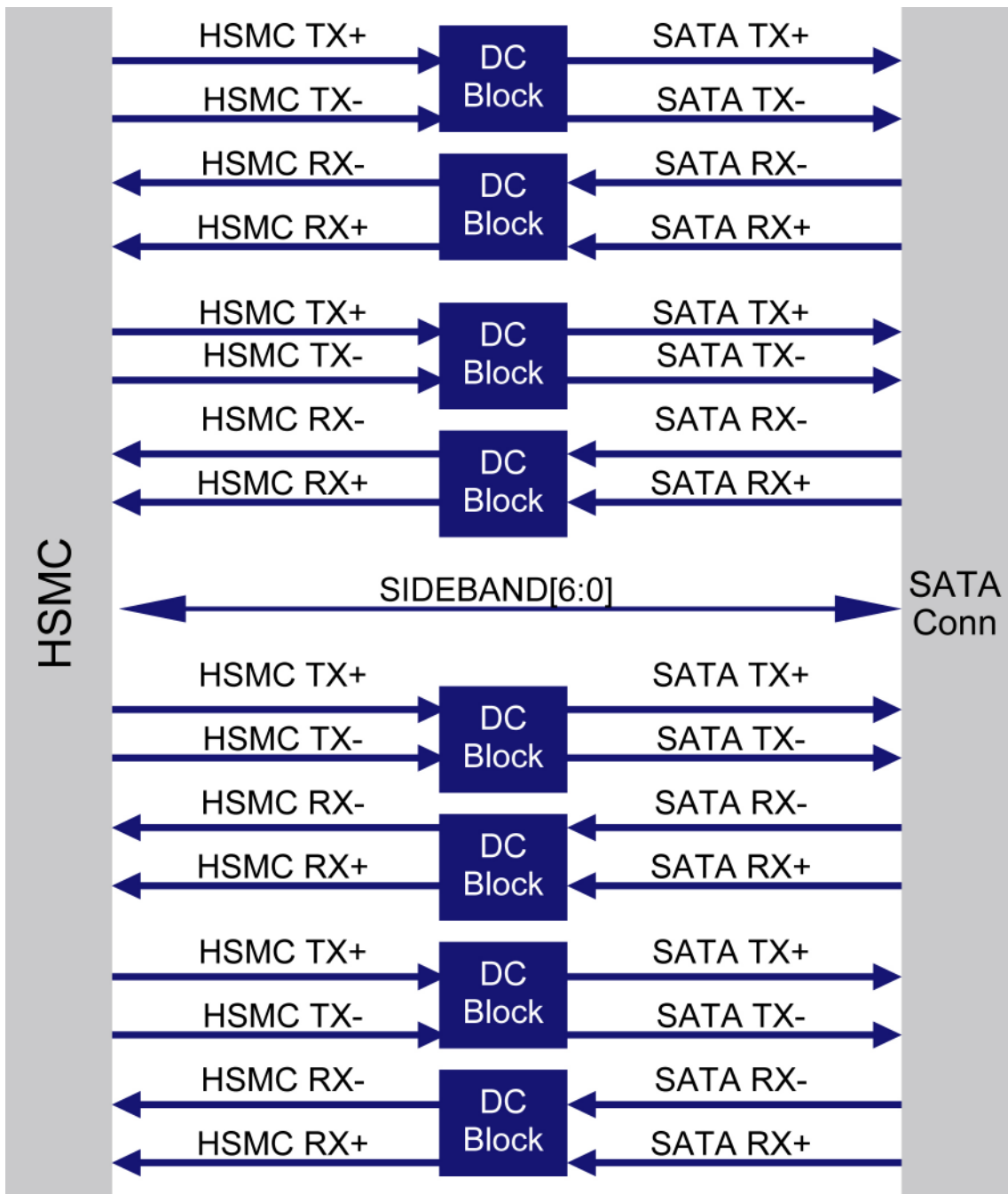

Figure 3.5 block diagram of the SATA/SAS 4 lane channel

3.6 Configuration, Status and Setup Elements

This section describes the configuration, status and setup elements of the SATA/SAS card

Configuration:

A jumper (J10) is available to disable the 12V to 5V regulator. If the on-board power output connector is not used it is recommended that the switching regulator be disabled by placing this jumper.

Setup:

An eight position user dip switch shown in [Figure 3.6](#) is supplied on the board to enable developers to have application specific user supplied setting. The dip switch is configured so that in the shorted position the higher number pins (9-16) are shorted to ground. The lower number pins (1-8) are connected to user signals that are attached to the HSMC lower speed signaling. The user dip switch can be used to control various modes depending on the user design. As with any user interface proper de-bouncing counters and synchronization circuitry is required for any proper design.

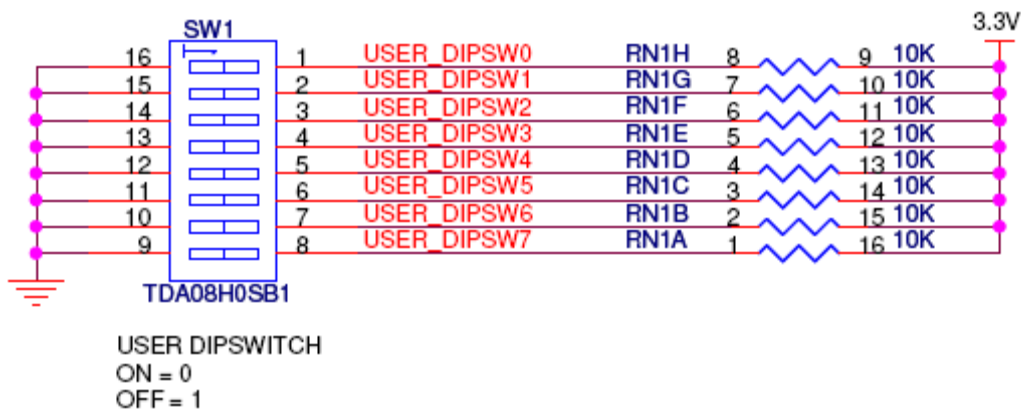

Figure 3.6 Eight position user dip switch

Status LEDs:

Component reference for LEDs describes board reference description signaling standard for the LEDs located on the SATA/SAS card. Each channel has a bi-colored LED for TX and RX

LED	Color	Description
D5	Blue	5V power
D9, D11, D2, D4	Bi-color Off/Red/Green/Orange (single lane transmit channels)	SATA/SAS transmit status (user function driven)
D8, D10, D1, D3	Bi-color Off/Red/Green/Orange (single lane receive channels)	SATA/SAS receive status (user function driven)
D16, D17, D18,	Bi-color off/Red/Green/Orange	SATA/SAS transmit status (user function driven)

Board Components

D19	(4 lane transmit channel)	
D12, D13, D14, D15	Bi-color off/Red/Green/Orange (4 lane receive channel)	SATA/SAS receive status (user function driven)

3.4 ATX Power

This section describes the ATX power provided on the SATA/SAS card

The SATA/SAS card consists of an ATX power connector to provide power to an attached disk drive unit. A switching regulator is used to generate 5V from 12V where the connector is rated to supply 1A of each voltage for use by the disk drive. [Figure 3.7](#) below shows the power tree of the ATX power connector.

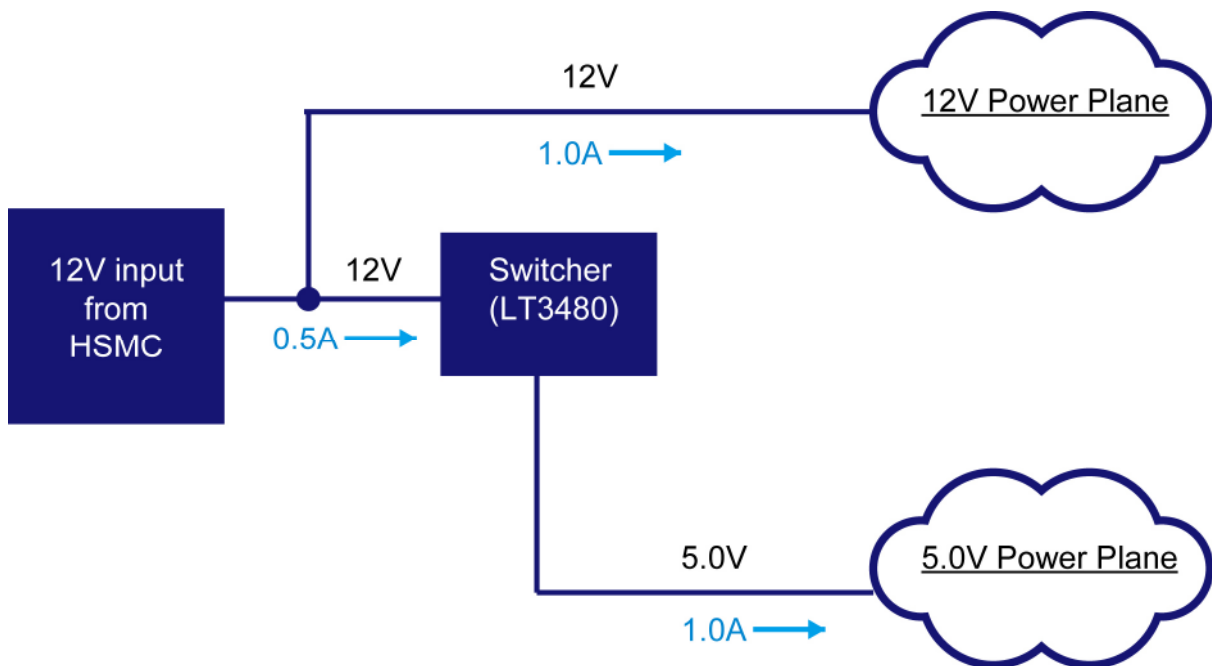

Figure 3.7 Power tree of ATX power connector

This chapter illustrates the reference design for the SATA/SAS daughter card.

4.1 Introduction

This section describes the functionality of the demonstration briefly.

The demonstration illustrates a loopback test for transceiver channels using the SATA/SAS daughter card and the Stratix IV GX development board. There are a total of 2 designs where the SATA reference clock is taken from different locations, HSMC connector and SMA connector respectively therefore either one can be driven. Note that if you select the HSMC connector to drive the SATA reference clock, a connection using the SMA cable is not required.

Users have the option of connecting the loopback connection to the single channels of the SATA connector or establishing the connection using the SATA/SAS 4x cable. Note that the SATA crossover cables are included in the kit can be only used on the single channel of the SATA connector. [Figure 4.1](#) and [Figure 4.2](#) depicts the block diagram for this demonstration. The design will run a well known repeating pattern on 4 or 8 SATA channels depending on the connection. The demonstration is intended for users to provide a basic instruction to the SATA/SAS daughter card with the procedures to control different hardware and software settings.

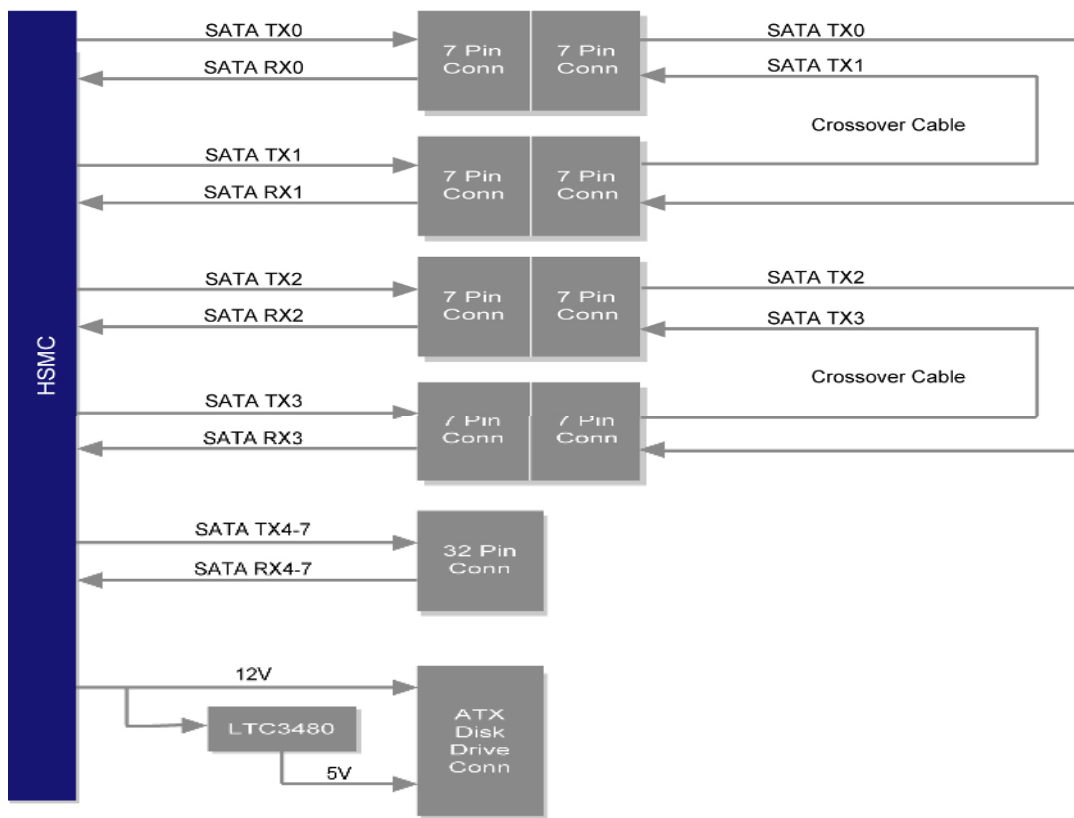

Figure 4.1 Block diagram of the SATA/SAS loopback design using the SATA loopback ribbon cable

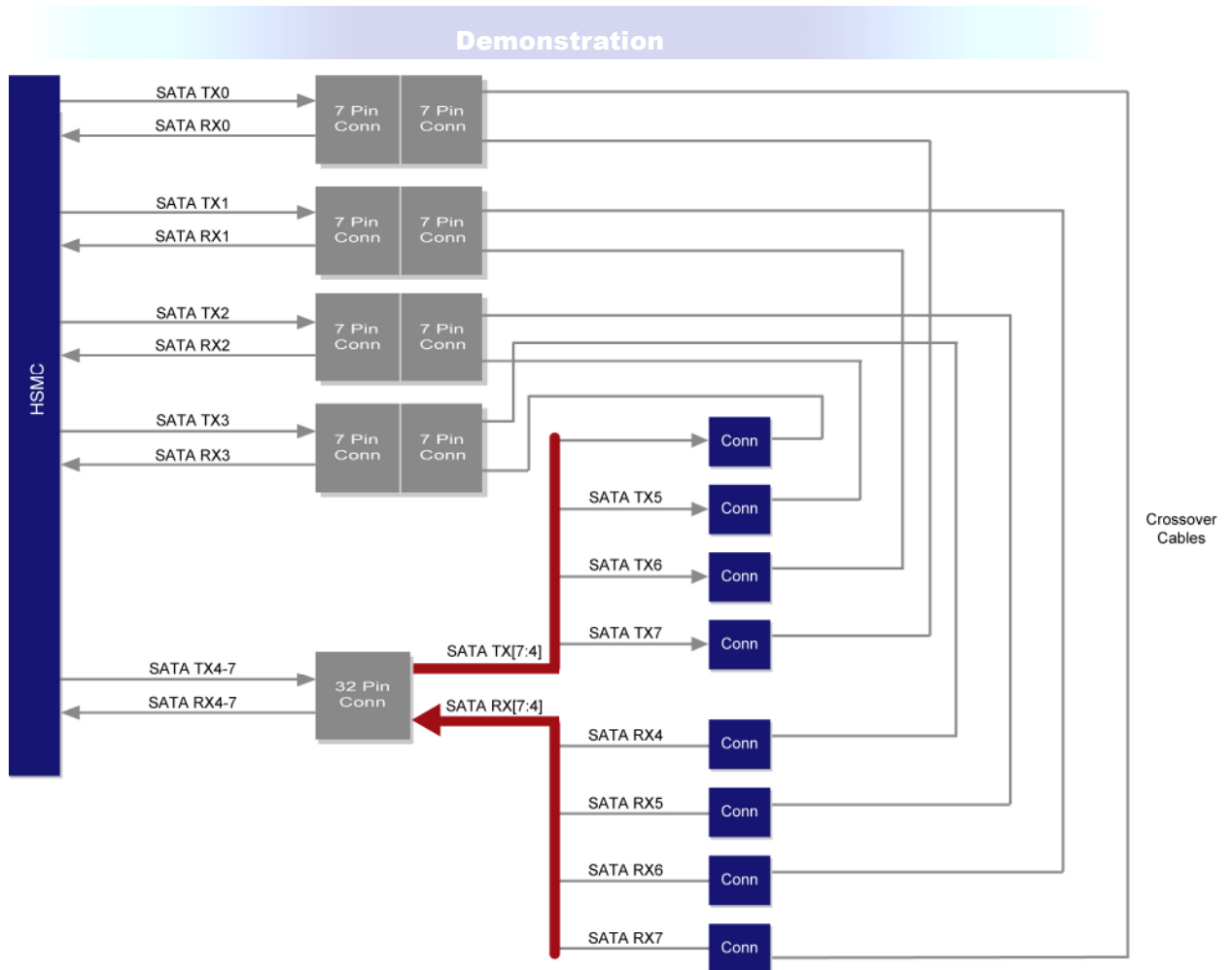

Figure 4.2 Block diagram of the SATA/SAS loopback design using the SATA/SAS 4x cable

4.2 System Requirements

The following items are required for the SATA/SAS loopback demonstration.

- SATA/SAS daughter card x 1
- Stratix IV GX FPGA Development Board x 1
- SATA loopback crossover signal ribbon cable x 2 (Included in the package)
- SATA/SAS 4x loopback cable (optional)
- SMA cable x 2 (If using the SMA SATA reference design)

4.3 Setup the Demonstration

Figure 4.3, 4.4, 4.4, 4.5, 4.6, and 4.7 shows how to setup hardware for the SATA demonstration.

- i. Plug in the SATA/SAS daughter card onto the Stratix IV GX development board. Note: The SATA/SAS card must be connected to HSMC Slot “A” of the Stratix IV GX FPGA Development Board for this demonstration.



Figure 4.3 Connecting the SATA/SAS daughter card to the Stratix IV development board

- ii. Set S4=[00011011] on the backside of the Stratix IV GX development board, follow by connecting the SMA clock between the SATA/SAS daughter card and Stratix IV GX development board as follows: (SATA_CLK_OUT_P ~ CLKIN_P, SATA_CLK_OUT_N ~ CLKIN_N)



Figure 4.4 SMA clock connection

- iii. Set the SATA/SAS board for 300MHz REFCLK by removing the CLK_FS (J7) jumper.
- iv. Option 1 (using single SATA channel): Connect the SATA loopback ribbon cable included in the package as follows: (SATA_CH_2 ~ SATA_CH_3, SATA_CH_0 ~ SATA_CH1)



Figure 4.5 SATA loopback ribbon cable connection

Demonstration

Option 2 (using 4x SATA channels): Connect a SATA/SAS 4x cable shown below

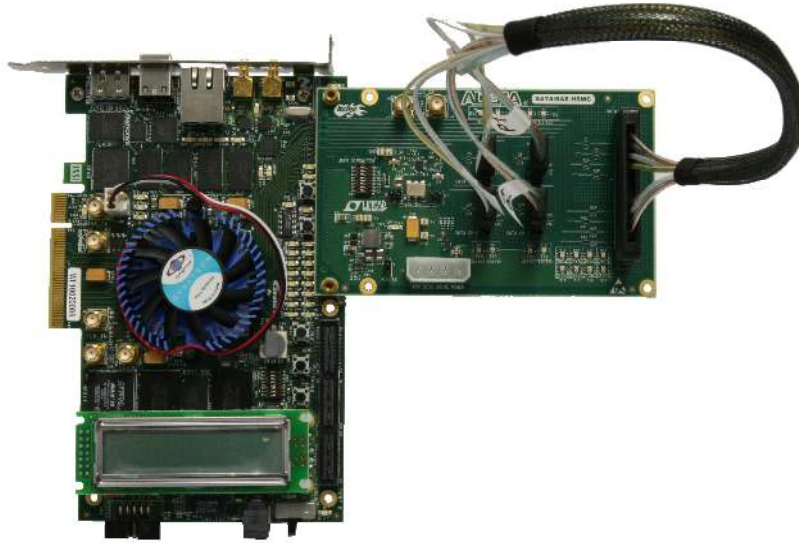

Figure 4.6 SATA/SAS 4x loopback connection

- v. Set USER_DIPS 0-3 = ON and 4-7 = OFF on the Stratix IV development board.

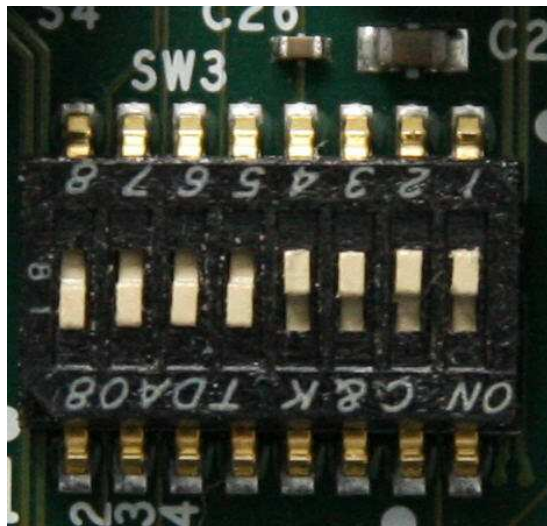

Figure 4.7 Stratix IV development board User DIP SW3 settings

4.4 Demo Operation

This section describes the procedures of running the demonstration

FPGA Configuration

Demonstration Setup, File Locations, and Instructions

SATA Transceiver Loopback Test Demo using SMA ref clock:

- Project directory: hsmc_loopback_dev_kit_refclk_s4gx230
- Bit Stream used: hsmc_loopback.sof
- Stratix IV GX FPGA Development Kit Setup
 - ✓ Set S4=[00011011] on backside of the Stratix IV GX development board.
 - ✓ Set the rotary switch (SW2) to the 0 position
- Power on the Stratix IV GX FPGA Development Board and download the SOF file (hsmc_loopback_dev_kit_refclk.sof)
- Press the CPU_RESET pushbutton. USER_LEDS 4-7 will display the “heartbeat” pattern, indicating that the FPGA’s state machine is running. LEDES (pcie_led_x1, pcie_led_x4, pcie_led_x8, pcie_led_g2) will also display the “heartbeat pattern”.
- Refer to Table 4.1 and Table 4.2 for the Pushbuttons and LED definitions.
- Press and release USER_PB[0]
- Press and release USER_PB[1]
- Press and release USER_PB[2]
- Confirm USER_LEDS 0, 1, and 2 illuminate, and USER_LED 3 is not illuminated. All 8 SATA_USER_LEDs will be GREEN if this step passes.
- Press both USER_PB[1] and USER_PB[2], then release both will create an error in the transmitter data stream.
- Confirm USER_LED 3 is illuminated. All RX_SATA_USER_LEDs for all tested channels will be RED.
- Simultaneously press USER_PB[0] and USER_PB[1], the SATA_USER_LED will show a moving ORANGE moving pattern with GREEN background.
- Simultaneously press USER_PB[0] and USER_PB[2], the SATA_USER_LED will show a moving ORANGE moving pattern with RED background.

SATA Transceiver Loopback Test Demo using HSMC ref clock:

FPGA Configuration

Demonstration Setup, File Locations, and Instructions

- Project directory: hsmc_loopback_hsmc_sata_refclk_s4gx230
- Bit Stream used: hsmc_loopback.sof
- Stratix IV GX FPGA Development Kit Setup
 - ✓ Set S4=[00011011] on backside of the Stratix IV GX development board.
 - ✓ Set the rotary switch (SW2) to the 0 position
- Power on the Stratix IV GX FPGA Development Board and download the SOF file

Demonstration

(hsmc_loopback_dev_kit_refclk.sof)

- Press the CPU_RESET pushbutton. USER_LEDS 4-7 will display the “heartbeat” pattern, indicating that the FPGA’s state machine is running. LEDS (pcie_led_x1, pcie_led_x4, pcie_led_x8, pcie_led_g2) will also display the “heartbeat pattern”.
- Refer to Table 4.1 and Table 4.2 for the Pushbuttons and LED definitions.
- Press and release USER_PB[0]
- Press and release USER_PB[1]
- Press and release USER_PB[2]
- Confirm USER LEDS 0, 1, and 2 illuminate, and USER_LED 3 is not illuminated. All 8 SATA_USER_LEDS will be GREEN if this step passes.
- Press both USER_PB[1] and USER_PB[2], then release both will create an error in the transmitter data stream.
- Confirm USER_LED 3 is illuminated. All RX_SATA_USER_LEDS for all tested channels will be RED.
- Simultaneously press USER_PB[0] and USER_PB[1], the SATA_USER_LED will show a moving ORANGE moving pattern with GREEN background.
- Simultaneously press USER_PB[0] and USER_PB[2], the SATA_USER_LED will show a moving ORANGE moving pattern with RED background.

Table 4.1 Pushbutton Functionality

Pushbutton	Description
Cpu_resetn	Resets the Board Test System
User_pb[0]	Enable Comma Detect
User_pb[1]	Enable channel Bond
User_pb[2]	Start transmitting PRBS data
User_pb[1&2]	Creates an error in the transmitter data stream
User_pb[0&1]	Creates an orange on green heartbeat pattern on the sata_user_leds
User_pb[0&2]	Creates an orange on red heartbeat pattern on the sata_user_leds

Table 4.2 LED Indicators

LED Indicators	Description
User_led[0]	PLLs are locked.
User_led[1]	Pattern Sync Acquired (World aligned, Channel Bonded, 1 st PRBS Data Received)
User_led[2]	Test Complete
User_led[3]	Error
User_led[7:4]	Heartbeat Pattern (FPGA design is functioning)

5.1 Revision History

Date	Change Log
March 1, 2010	Initial Version

5.2 Always Visit SATA Webpage for New Main board

We will be continuing providing interesting examples and labs on our SATA

webpage. Please visit www.altera.com or sata.terasic.com for more information.