

# DCmind: DC DIRECT-DRIVE BRUSH MOTORS

Ø 63 mm - 209 W

- › Silent motor
- › 24 V built in EMC filter class B
- › Excellent efficiency
- › Long life
- › IP65
- › In accordance with UL - CE - ROHS regulations



## Part numbers

	24 V	48 V	90 V	120 V
Type	89890	89890	89890	89890
Voltage	24 V <sup>---</sup>	48 V <sup>---</sup>	90 V <sup>---</sup>	120 V <sup>---</sup>
<b>References</b>				
Option: IP65 level	89890011	89890003	89890004	89890005
Option: holding brake 0.5 Nm, 24 V <sup>---</sup>	89890511	89890503	89890504	89890505
Option: 2 channels encoder 1000 pulses/revolution, 5 V <sup>---</sup>	89890911	89890903	89890904	89890905
<b>No-load characteristics</b>				
Speed (rpm)	4000	3780	3700	3730
Absorbed current (A)	0.34	0.16	0.09	0.07
<b>Nominal characteristics</b>				
Speed (rpm)	3430	3370	3320	3350
Torque (mNm)	290	290	290	290
Output power (W)	104	102	101	102
Absorbed current (A)	5.4	2.53	1.34	1.01
Efficiency (%)	80	84	84	84
<b>Maximum efficiency characteristics</b>				
Speed (rpm)	3660	3480	3410	3430
Torque (mNm)	179	207	218	230
Output power (W)	69	75	78	83
Absorbed current (A)	3.5	1.9	1	0.82
Efficiency (%)	82	84	84	84
<b>General characteristics</b>				
Insulation conforming to IEC60085	Class E	Class E	Class E	Class E
Noise level (dBA)	35	35	35	35
Max. output power (W)	209	265	269	281
Starting torque (mNm)	2000	2680	2780	2875
Starting current (A)	35.3	22.2	12.1	9.4
Resistance (Ω)	0.7	2.2	7.4	12.8
Inductance (mH)	0.73	3.3	12	21
Torque constant (mNm/A)	57	122	232	308
Electrical time constant (ms)	1.1	1.5	1.6	1.6
Mechanical time constant (ms)	13	9	9	9
Inertia (g.cm <sup>2</sup> )	650	650	650	650
Weight (g)	1600	1600	1600	1600
Commutator segments	12	12	12	12
Service life (h)	5000	5000	5000	5000
Wires length (mm)	200	200	200	200
Ball bearing	✓	✓	✓	✓
<b>Comments</b>				
IP65 level except for the output shaft. Encoder and brake options are IP20.				

## Product adaptations, contact us



- › Special output shaft
- › Shaft with pinion, pulley, worm gear
- › Special supply voltage
- › Other wire length
- › Optical or Hall effect encoder - 1 or 2 channels
- › Specific motor mounting flange
- › Special motor connectors
- › IP67, IP69K

Product made to order

## Curves

89890011 - 89890511 - 89890911

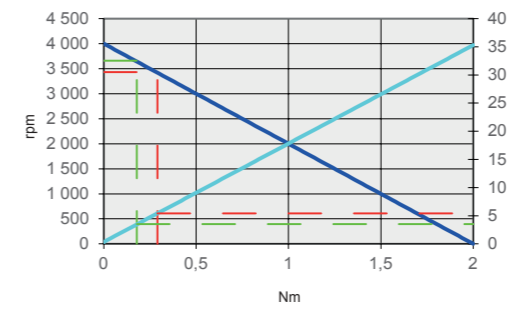

89890003 - 89890503 - 89890903

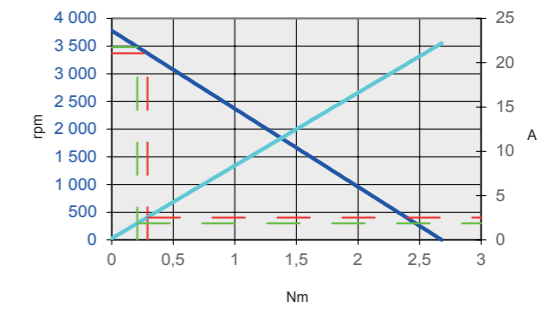

89890004 - 89890504 - 89890904

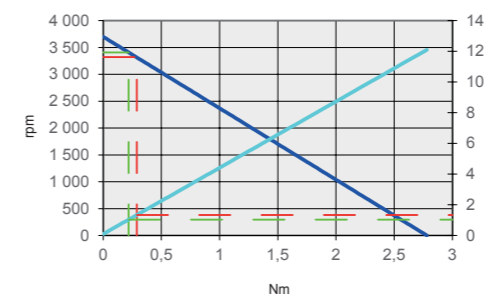

89890005 - 89890505 - 89890905

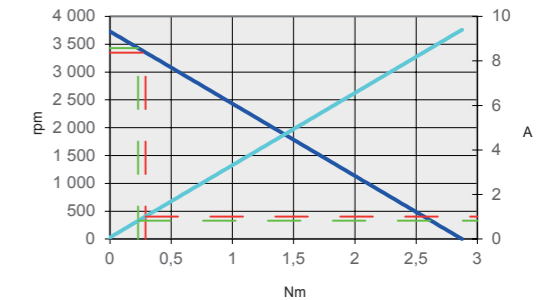

- Speed (rpm)
- Current (A)
- Torque at nominal
- Torque at maximum efficiency

## Dimensions (mm)

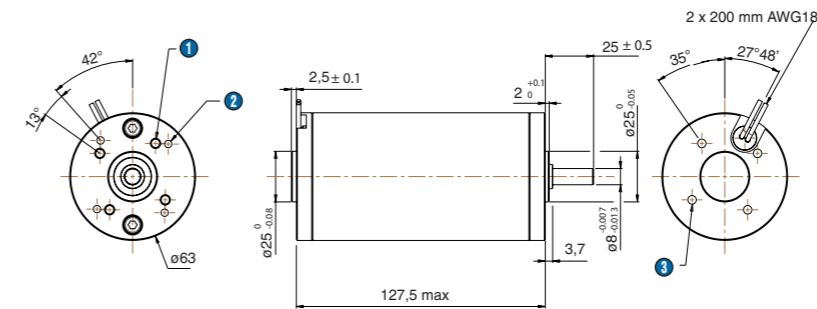

- 1 4 x M5 at 90° depth 10 over Ø 40
- 2 4 x Ø 3.65 at 90° depth 8 over Ø 40
- 3 4 x M5 at 90° depth 7 over Ø 40

## Options

### Holding brake 0.5 Nm

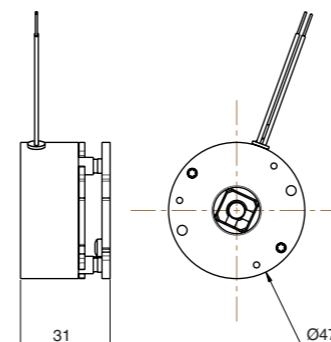

### Encoder

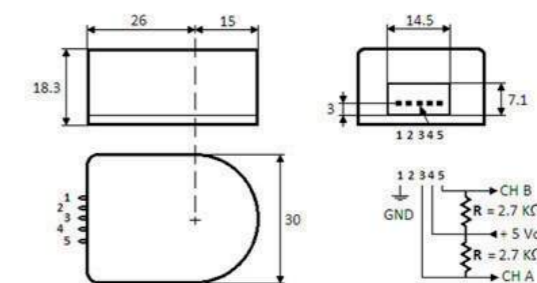

# GEARBOXES FOR DCmind BRUSH RANGE

## 3 to 25 Nm

- › Planetary and worm gearboxes, very silent versions
- › Shafts on ball bearings
- › Long service life

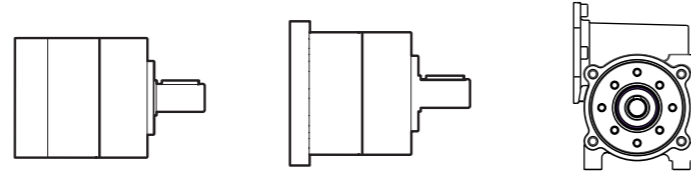

### Part numbers

Gearboxes									
Family	A1			B1			RAD10		
Type of gearbox	Planetary $\varnothing$ 42			Planetary $\varnothing$ 52			Worm gear		
Associated motors	Gear motor reference			Gear motor reference			Gear motor reference		
89810 IP65 / Holding brake / Encoder	8981 A1 / A5 / A9								
89800 IP65 / Holding brake / Encoder	8980 A1 / A5 / A9								
89850 IP65 / Holding brake / Encoder	8985 A1 / A5 / A9								
89830 IP65 / Holding brake / Encoder				8983 B1 / B5 / B9			8983 10 / 15 / 19		
89890 IP65 / Holding brake / Encoder				8989 B1 / B5 / B9			8989 10 / 15 / 19		
General characteristics									
Number of stages	1	2	3	1	2	3	1		
Maximum permitted torque (Nm)	3	7.5	15	4	12	25	10		
Efficiency	0.8	0.75	0.7	0.8	0.75	0.7	0.6 → 0.3		
Axial dynamic load (daN)	5	8	11	6	10	15	10		
Radial dynamic load (daN)	16	23	30	20	32	45	15		
Weight (kg)	0.3	0.4	0.5	0.7	0.9	1.1	0.6		
Standard reduction ratios	9	45	302	7-9	28-45	302	5 - 10 - 20 - 30 - 50		
Other ratios possible	58 - 137 - 232 - 393			58 - 137 - 192 - 232 - 393			15 - 100		
Operating temperature	-30 → +70°C			-30 → +70°C			-10 → +75°C		
Typical noise level	45 dBA			45 dBA			45 dBA		
Comments									
<b>Planetary gearboxes:</b>									
To maintain a very low noise level, the motor pinion is precision machined on motor shaft to obtain optimum concentricity and parallelism. The gears in the first stage are helical-cut and made from a composite material. This design significantly improves gear life by reducing wear due to friction, increases gearbox efficiency and ensures a very low noise level even with the gearbox under load.									
<b>Worm gearbox:</b>									
This gearbox combines a tempered steel worm gear with a hardened bronze helical wheel, a combination that ensures a long service life. The helical wheel rotates in a grease reservoir to provide an excellent slip coefficient and dissipate heat. O-rings and lip seals equipped with garter springs are used to ensure sealing the gearbox output shaft.									
The gearbox casing is made of aluminium to maximize heat dissipation.									
However, because of the high power rating of this gearbox and the lower efficiency inherent in ratio worm gearboxes, care must be taken not to exceed a temperature of 75°C on the gearbox casing during operation.									
The output shaft configuration can be right, left, or a dual shaft (shaft output on both sides).									

### Product adaptations, contact us



- › Special shafts
- › Other reduction ratios
- › Other fixing holes
- › Special mounting flange

### Dimensions (mm)

Planetary gearbox  $\varnothing$  42 type A1

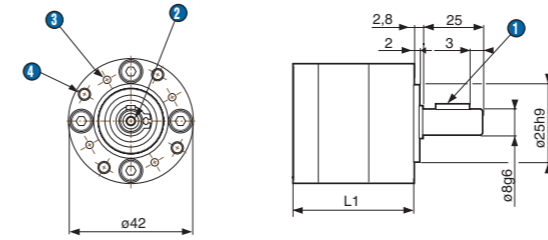

- 1 Parallel key 3 x 3 x 16 DIN6885
- 2 M3, depth 9
- 3 4 x M3 at 90°, depth 7 over  $\varnothing$  32
- 4 4 x M4 at 90°, depth 10 over  $\varnothing$  36

L1 1 stage: 48.5 max.  
L1 2 stages: 61.6 max.  
L1 3 stages: 74.7 max.

Planetary gearbox  $\varnothing$  52 type B1

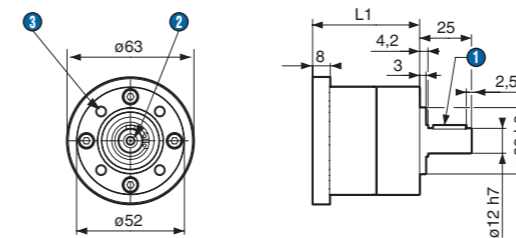

- 1 Parallel key 4 x 4 x 16 DIN6885
- 2 M4, depth 10
- 3 4 x M5 at 90°, depth 10 over  $\varnothing$  40

L1 1 stage: 56.1 max.  
L1 2 stages: 70.3 max.  
L1 3 stages: 84.5 max.

Worm gearbox RAD10

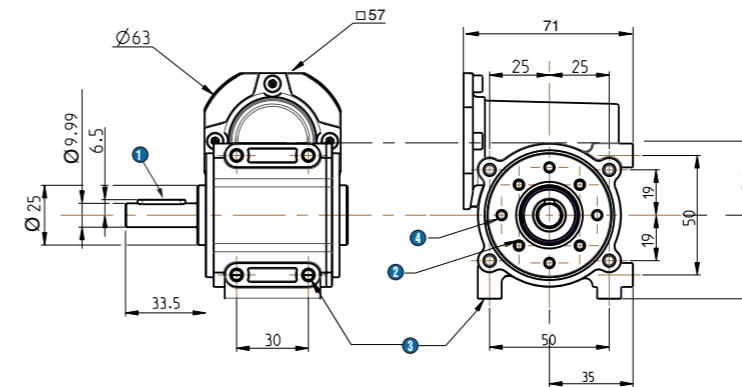

- 1 Parallel key 4 x 4 x 20 DIN6885
- 2 4 x M4, depth 8 over  $\varnothing$  36
- 3 8 x M5, depth 8
- 4 4 x  $\varnothing$  3.8 depth 10 over  $\varnothing$  40

The left-hand and right-hand sides of the gearbox are identical.

