

Silicon Phototransistor and Photo Darlington in 1210 SMD Package

OP525, OP525DA, OP525F



Features:

- High Speed and High photo sensitivity
- Fast response time
- 1210 package size
- High Current Gain
- Water clear and black lens choices
- Narrow Viewing Receiving Angle
- Compatible with IR Reflow soldering process
- Moisture Sensitivity Level: MSL3



Description:

These devices consist of an NPN silicon phototransistor and photo darlington mounted in a miniature SMD package with a 1210 size chip carrier that is compatible with most automated mounting and position sensing equipment.

The **OP525** devices have a 1.8mm domed lens and viewing acceptance angle of 25° with higher collector current gains due to the lenses on package. The **OP525** and **OP525DA** have a water clear lens that senses ambient light to higher wavelengths for applications from 450nm to 1120nm. The **OP525F** has a black domed lens to reduce ambient light noise.

The **OP525** series are tested using infrared light for close correlation with Optek GaAs and GaAlAs emitters. Photo darlington devices are normally used in application where light signals are low and more current gain is needed than is possible with phototransistors.

Applications:

- Non-contact position sensing
- Datum detection
- Machine automation
- Optical encoders
- Reflective and transmissive sensors

Ordering Information		
Part Number	Sensor	Viewing Angle
OP525	Phototransistor	25°
OP525DA	Photo Darlington	25°
OP525F	Phototransistor	25°

OP525 and OP525F

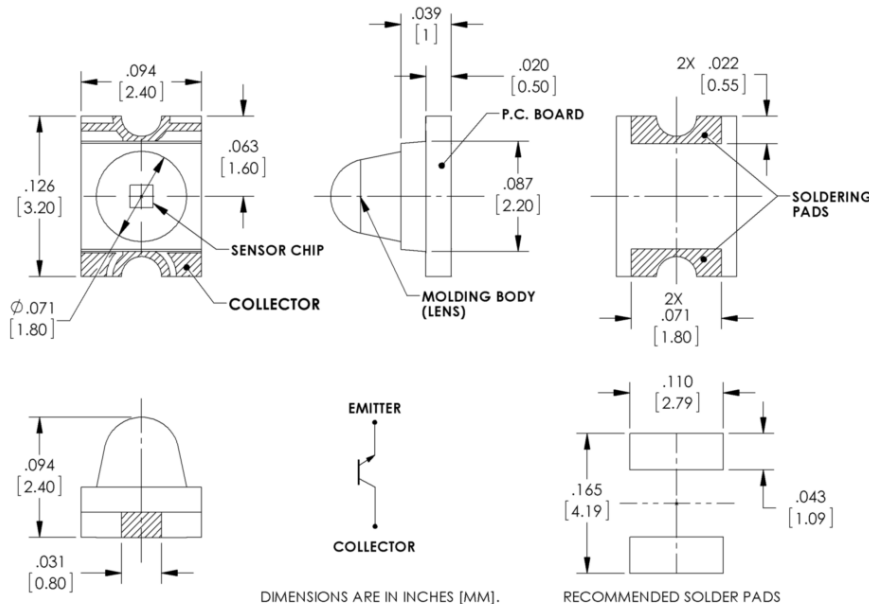

Pin #	Transistor
1	Collector
2	Emitter



RoHS

OPTEK reserves the right to make changes at any time in order to improve design and to supply the best product possible.

Silicon Phototransistor and Photo Darlington in 1210 SMD Package

OP525, OP525DA, OP525F



OP525DA Package Dimensions

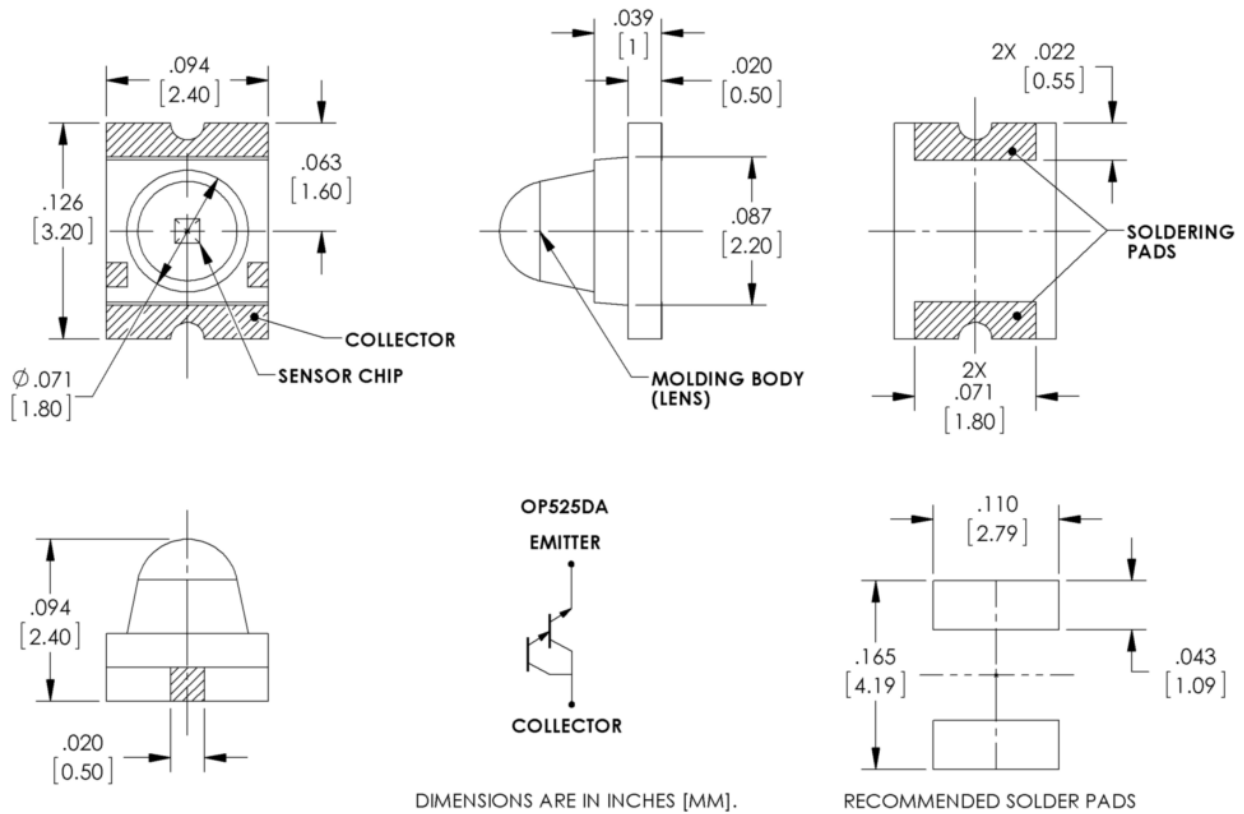

Pin #	Transistor
1	Collector
2	Emitter

Recommended Solder Pad Patterns

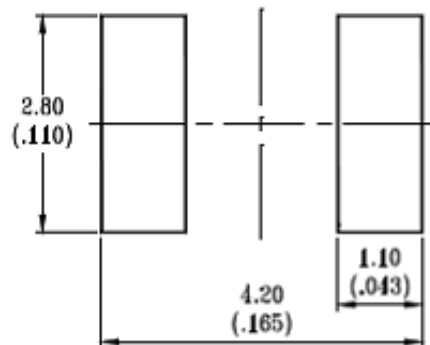

OPTEK reserves the right to make changes at any time in order to improve design and to supply the best product possible.

**Silicon Phototransistor and Photo Darlington
in 1210 SMD Package
OP525, OP525DA, OP525F**



Absolute Maximum Ratings ($T_A=25^\circ\text{C}$ unless otherwise noted)

Storage Temperature Range	-40° C to +100° C
Operating Temperature Range	-40° C to +80° C
Lead Soldering Temperature ⁽¹⁾	260° C
Collector-Emitter Voltage OP525, OP525F OP525DA	30 V 35 V
Emitter-Collector Voltage	5 V
Collector Current OP525, OP525F OP525DA	20 mA 30 mA
Power Dissipation ⁽²⁾ OP525, OP525F OP525DA	75 mW 100 mW

Electrical Characteristics ($T_A = 25^\circ\text{C}$ unless otherwise noted)

SYMBOL	PARAMETER	MIN	TYP	MAX	UNITS	TEST CONDITIONS
--------	-----------	-----	-----	-----	-------	-----------------

Input Diode

$I_{C(ON)}$	On-State Collector Current OP525F OP525 OP525DA	2.0 1.0 10.0	- - -	- - -	mA	$V_{CE} = 5.0\text{ V}, E_E = 0.5\text{ mW/cm}^2$ $V_{CE} = 5.0\text{ V}, E_E = 1.5\text{ mW/cm}^2$ ⁽³⁾ $V_{CE} = 5.0\text{ V}, E_E = 0.15\text{ mW/cm}^2$ ⁽³⁾
$V_{CE(SAT)}$	Collector-Emitter Saturation Voltage OP525, OP525F OP525DA	- -	- -	0.4 1.7	V	$I_C = 100\ \mu\text{A}, E_E = 1.0\text{ mW/cm}^2$ ⁽³⁾ $I_C = 1\text{ mA}, E_E = 0.5\text{ mW/cm}^2$ ⁽³⁾
I_{CEO}	Collector-Emitter Dark Current OP525, OP525F OP525DA	-	-	100 200	nA	$V_{CC} = 10.0\text{ V}$ ⁽⁴⁾
$V_{BR(CEO)}$	Collector-Emitter Breakdown Voltage OP525, OP525F OP525DA	30 35	-	-	V	$I_C = 100\ \mu\text{A}, E_E = 0$ $I_C = 1\text{ mA}, E_E = 0$
$V_{BR(ECO)}$	Emitter-Collector Breakdown Voltage OP525, OP525F OP525DA	5 5	- -	- -	V	$I_E = 100\ \mu\text{A}, E_E = 0$ $I_E = 100\ \mu\text{A}, E_E = 0$
t_r, t_f	Rise and Fall Times OP525, OP525F OP525DA	-	15 50	- -	μs	$I_C = 1\text{ mA}, R_L = 1\text{ K}\Omega$ $I_C = 1\text{ mA}, R_L = 1\text{ K}\Omega$
$\lambda\ 0.5$	Spectral Bandwidth OP525F	750	-	1100	nm	-

Notes:

- Solder time less than 5 seconds at temperature extreme.
- Derate linearly at 1.33 mW/° C above 25° C.
- Light source is an unfiltered GaAs LED with a peak emission wavelength of 935 nm and a radiometric intensity level which varies less than 10% over the entire lens surface of the phototransistor being tested.
- To calculate typical collector dark current in μA , use the formula $I_{CEO} = 10^{(0.04 t - 3)}$, where T_A is the ambient temperature in ° C.

OPTEK reserves the right to make changes at any time in order to improve design and to supply the best product possible.

**Silicon Phototransistor and Photo Darlington
in 1210 SMD Package
OP525, OP525DA, OP525F**



OP525 and OP525DA

Relative Response vs. Wavelength

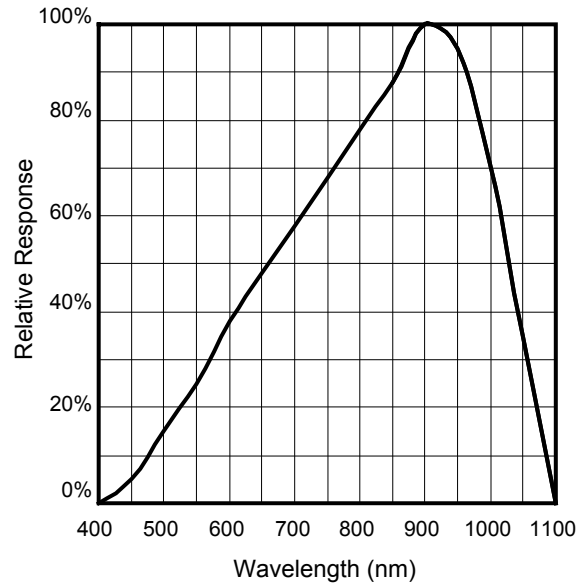

OP525

Collector Current— I_C (mA) vs
Collector-Emitter Voltage V_{CE} (V)

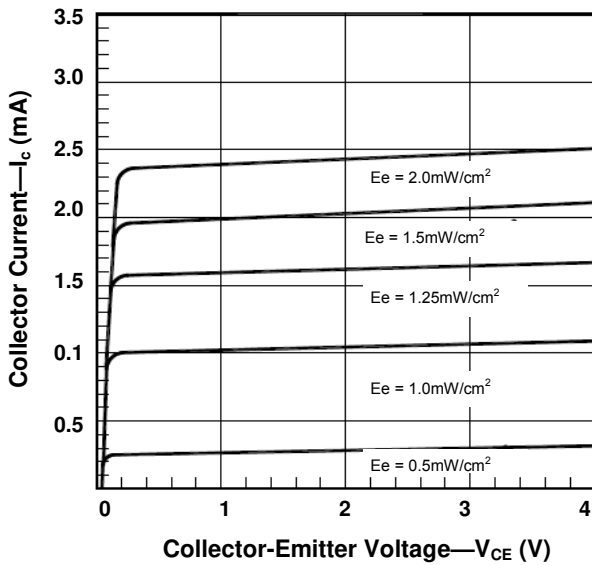

Collector Current— I_C (mA) vs
Optical Power— E_e (mW/cm²)

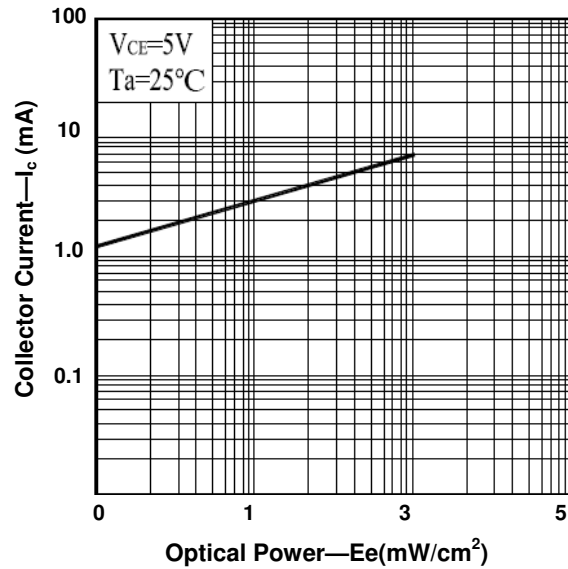

OPTEK reserves the right to make changes at any time in order to improve design and to supply the best product possible.

Silicon Phototransistor and Photo Darlington in 1210 SMD Package

OP525, OP525DA, OP525F



OP525DA

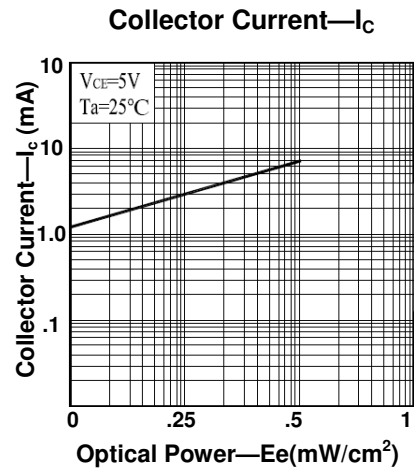
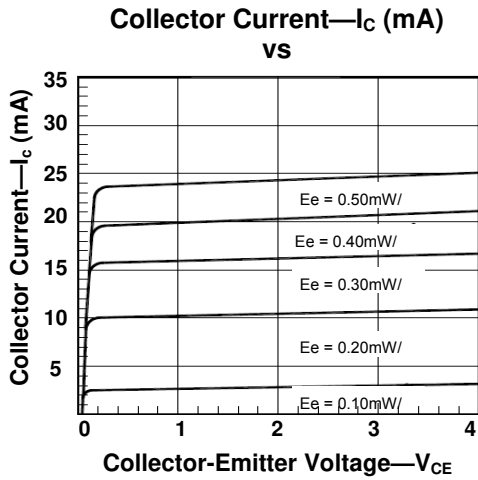

OP525F

Sensitivity Chart

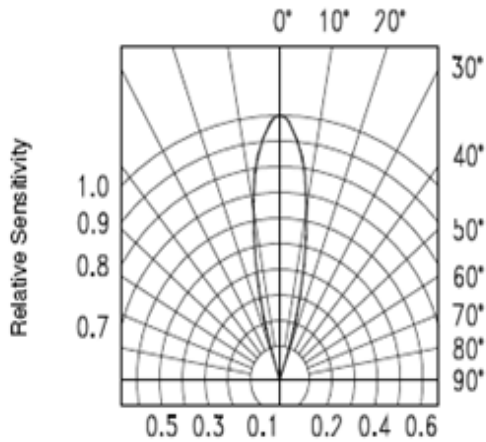

Spectral Sensitivity
Relative Response Vs. Wavelength

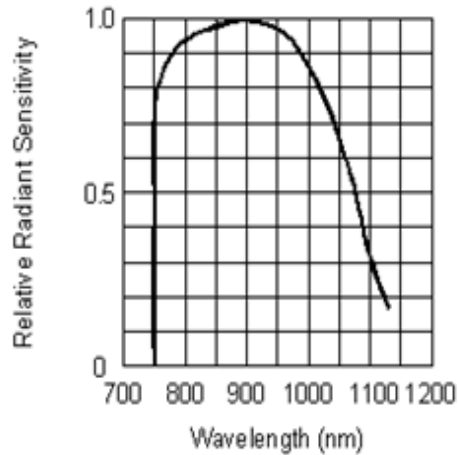

Relative Collector Current vs.Irradiance

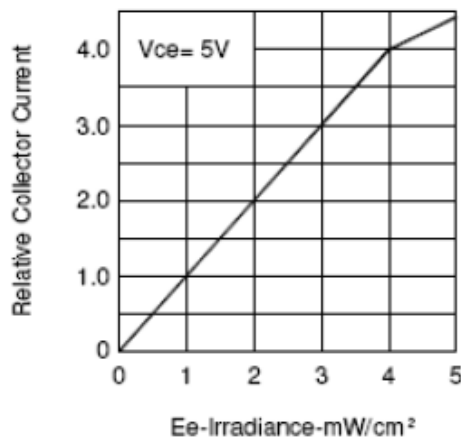

OPTEK reserves the right to make changes at any time in order to improve design and to supply the best product possible.