

THIS DOCUMENT CONTAINS DATA PROPRIETARY TO PROJECTS UNLIMITED, INC. ANY USE OR REPRODUCTION, IN ANY FORM, WITHOUT PRIOR WRITTEN PERMISSION OF PROJECTS UNLIMITED, INC. IS PROHIBITED.
© 2005, Projects Unlimited Inc.

SPECIFICATIONS

PARAMETERS	VALUES	UNITS
RESONANT FREQUENCY	2000±500	Hz
RESONANT IMPEDANCE (MAX)	300	Ohm
MAX INPUT VOLTAGE	30	Vp-p
CAPACITANCE @ 1kHz	45000±30%	pF
PLATE MATERIAL	BRASS	-
OPERATING TEMPERATURE	-20 ~ +60	°C
STORAGE TEMPERATURE	-20 ~ +70	°C

REVISIONS			
LTR	DESCRIPTION	DATE	APPROVED
-	RELEASED FROM ENGINEERING	1/22/10	
A	REVISED SOLDER PLACEMENT	4/22/10	B.R.

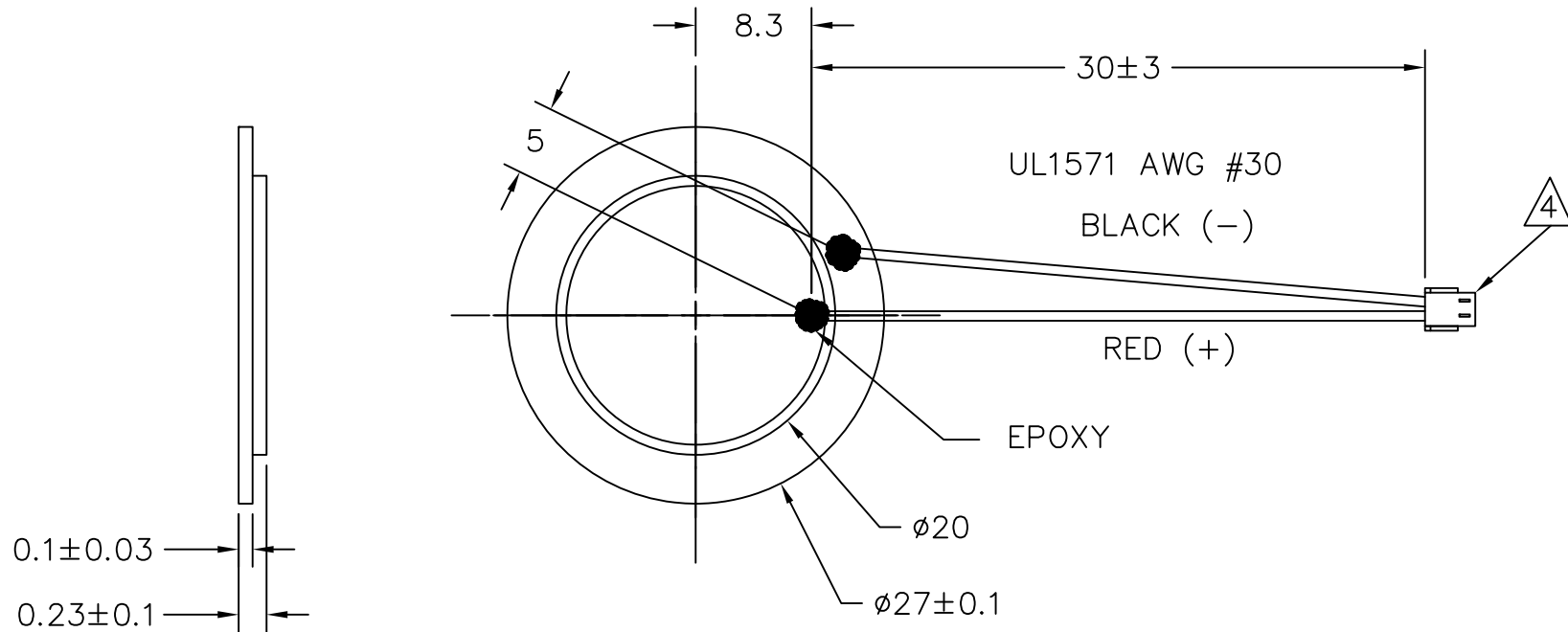

NOTES:

1. ALL DIMENSIONS ARE IN MILLIMETERS.
2. SPECIFICATION SUBJECT TO CHANGE OR WITHDRAWAL WITHOUT NOTICE.
3. THIS PART IS RoHS 2002/95/EC COMPLIANT.
4. JST CONNECTOR: 02SR-3S

FILE NAME
AB2720B-LWC30-R.DWG

UNLESS OTHERWISE SPECIFIED: DIMENSIONS ARE IN MILLIMETERS, TOLERANCES ARE ±0.5 AND ANGLES ARE ±3°.		 A Division of Projects Unlimited		6300 Sand Lake Road Dayton, Ohio 45414	
APPROVALS		DATE		BENDER DRAWING NO. AB2720B-LWC30-R	
DRAWN <i>B.R.</i>		1/10			
CHECKED <i>C.W.</i>		1/10			
APPROVED <i>B.R.</i>		1/10			
SIZE A		SCALE: N.T.S.		SHEET 1 OF 1	